



Chipsmall Limited consists of a professional team with an average of over 10 year of expertise in the distribution of electronic components. Based in Hongkong, we have already established firm and mutual-benefit business relationships with customers from,Europe,America and south Asia,supplying obsolete and hard-to-find components to meet their specific needs.

With the principle of “Quality Parts,Customers Priority,Honest Operation,and Considerate Service”,our business mainly focus on the distribution of electronic components. Line cards we deal with include Microchip,ALPS,ROHM,Xilinx,Pulse,ON,Everlight and Freescale. Main products comprise IC,Modules,Potentiometer,IC Socket,Relay,Connector.Our parts cover such applications as commercial,industrial, and automotives areas.

We are looking forward to setting up business relationship with you and hope to provide you with the best service and solution. Let us make a better world for our industry!



## Contact us

Tel: +86-755-8981 8866 Fax: +86-755-8427 6832

Email & Skype: info@chipsmall.com Web: www.chipsmall.com

Address: A1208, Overseas Decoration Building, #122 Zhenhua RD., Futian, Shenzhen, China



# TLE 4267-2

5-V Low Drop Voltage Regulator

Data Sheet

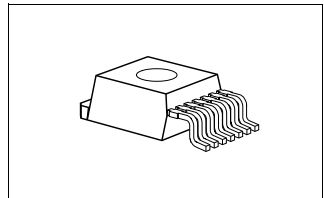
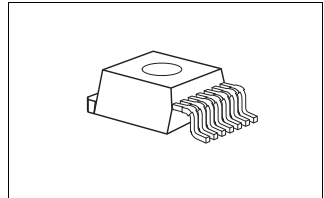
Rev. 1.0, 2012-04-03

Automotive Power



## Features

- Output voltage tolerance  $\leq \pm 2\%$
- 400 mA output current capability
- Low-drop voltage
- Very low standby current consumption
- Input voltage up to 40 V
- Overvoltage protection up to 60 V ( $\leq 400$  ms)
- Reset function down to 1 V output voltage
- ESD protection up to 2000 V
- Adjustable reset time
- On/off logic
- Overtemperature protection
- Reverse polarity protection
- Short-circuit proof
- Wide temperature range
- Suitable for use in automotive electronics
- Green Product (RoHS compliant)
- AEC Qualified



## Functional Description

The TLE 4267-2 G is a 5-V low drop voltage regulator for automotive applications in a PG-TO220-7-4 package. It supplies an output current of  $> 400$  mA. The IC is shortcircuit-proof and has an overtemperature protection circuit.

Type	Package
TLE 4267-2 G	PG-TO220-7-4
TLE 4267-2 G	PG-TO263-7-1

## Application

The IC regulates an input voltage  $V_I$  in the range of  $5.5 \text{ V} < V_I < 40 \text{ V}$  to a nominal output voltage of  $V_Q = 5.0 \text{ V}$ . A reset signal is generated for an output voltage of  $V_Q < V_{RT}$ . The reset delay can be set with an external capacitor. The device has two logic inputs. A voltage of  $V_{E2} > 4.0 \text{ V}$  given to the E2-pin (e.g. by ignition) turns the device on. Depending on the voltage on pin E6 the IC may be hold in active-state even if  $V_{E2}$  goes to low level. This makes it simple to implement a self-holding circuit without external components. When the device is turned off, the output voltage drops to 0 V and current consumption tends towards 0  $\mu\text{A}$ .

## Design Notes for External Components

The input capacitor  $C_I$  is necessary for compensation of line influences. The resonant circuit consisting of lead inductance and input capacitance can be damped by a resistor of approx. 1  $\Omega$  in series with  $C_I$ . The output capacitor is necessary for the stability of the regulating circuit. Stability is guaranteed at values of  $\geq 22 \mu\text{F}$  and an ESR of  $\leq 3 \Omega$  within the operating temperature range.

## Circuit Description

The control amplifier compares a reference voltage, which is kept highly accurate by resistance adjustment, to a voltage that is proportional to the output voltage and drives the base of the series transistor via a buffer. Saturation control as a function of the load current prevents any over-saturating of the power element.

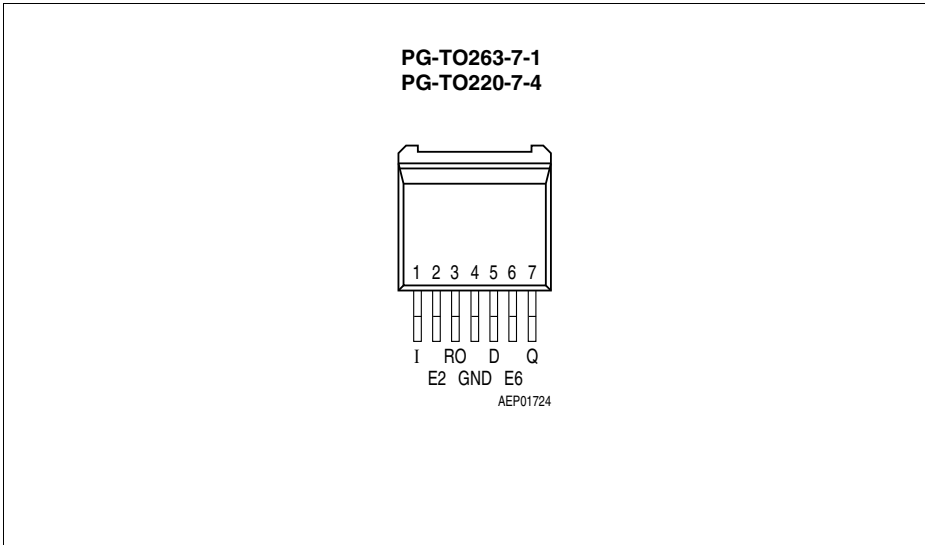
The reset output RO is in high-state if the voltage on the delay capacitor  $C_D$  is greater or equal  $V_{UD}$ . The delay capacitance  $C_D$  is charged with the current  $I_D$  for output voltages greater than the reset threshold  $V_{RT}$ . If the output voltage gets lower than  $V_{RT}$  a fast discharge of the delay capacitor  $C_D$  sets in and as soon as  $V_{CD}$  gets lower than  $V_{LD}$  the reset output RO is set to low-level (see [Figure 5](#)). The reset delay can be set within wide range by dimensioning the capacitance of the external capacitor.

**Table 1 Truth Table for Turn-ON/Turn-OFF Logic**

<b>E2, Inhibit</b>	<b>E6, Hold</b>	<b>V<sub>Q</sub></b>	<b>Remarks</b>
L	X	OFF	Initial state
H	X	ON	Regulator switched on via Inhibit, by ignition for example
H	L	ON	Hold clamped active to ground by controller while Inhibit is still high
X	L	ON	Previous state remains, even ignition is shut off: self-holding state
L	L	ON	Ignition shut off while regulator is in self-holding state
L	H	OFF	Regulator shut down by releasing of Hold while Inhibit remains Low, final state. No active clamping required by external self-holding circuit ( $\mu\text{C}$ ) to keep regulator in off-state.

Inhibit: E2 Enable function, active High

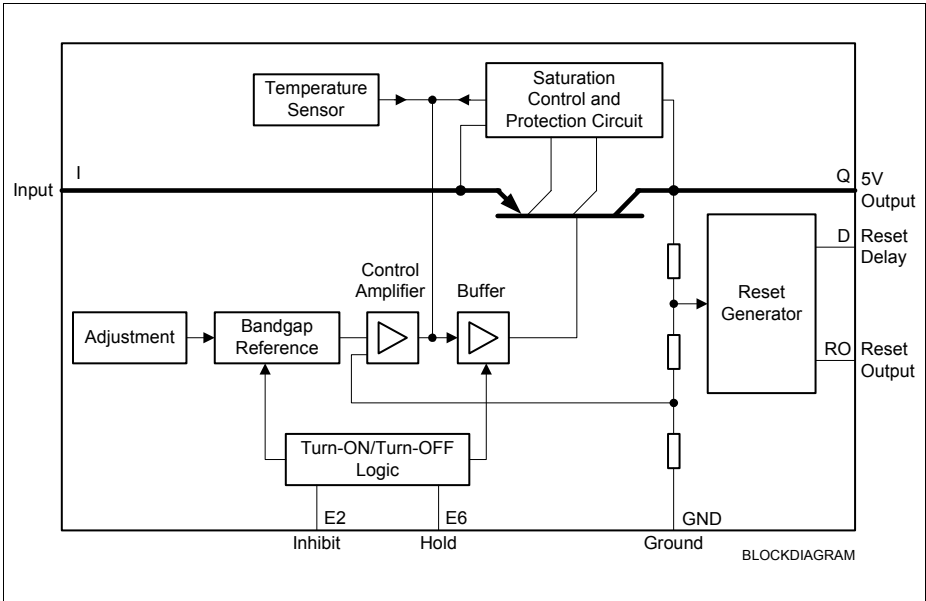
Hold: E6 Hold and release function, active Low



**Figure 1 Pin Configuration** (top view)

**Table 2 Pin Definitions and Functions**

Pin	Symbol	Function
1	I	<b>Input</b> ; block to ground directly at the IC by a ceramic capacitor
2	E2	<b>Inhibit</b> ; device is turned on by High signal on this pin; internal pull-down resistor of 100 k $\Omega$
3	RO	<b>Reset Output</b> ; open-collector output internally connected to the output via a resistor of 30 k $\Omega$
4	GND	<b>Ground</b> ; connected to rear of chip
5	D	<b>Reset Delay</b> ; connect via capacitor to GND
6	E6	<b>Hold</b> ; see <a href="#">Table 1</a> for function; this input is connected to output voltage via a pull-up resistor of 50 k $\Omega$
7	Q	<b>5-V Output</b> ; block to GND with 22- $\mu$ F capacitor, ESR < 3 $\Omega$



**Figure 2**    **Block Diagram**

**Table 3 Absolute Maximum Ratings**
 $T_J = -40$  to  $150\text{ }^\circ\text{C}$ 

Parameter	Symbol	Limit Values		Unit	Notes
		Min.	Max.		
<b>Input</b>					
Voltage	$V_I$	-42	42	V	–
Voltage	$V_I$	–	60	V	$t \leq 400\text{ ms}$
Current	$I_I$	–	–	–	internally limited
<b>Reset Output</b>					
Voltage	$V_{RO}$	-0.3	7	V	–
Current	$I_{RO}$	–	–	–	internally limited
<b>Reset Delay</b>					
Voltage	$V_D$	-0.3	42	V	–
Current	$I_D$	–	–	–	–
<b>Output</b>					
Voltage	$V_Q$	-0.3	7	V	–
Current	$I_Q$	–	–	–	internally limited
<b>Inhibit</b>					
Voltage	$V_{E2}$	-42	42	V	–
Current	$I_{E2}$	-5	5	mA	$t \leq 400\text{ ms}$
<b>Hold</b>					
Voltage	$V_{E6}$	-0.3	7	V	–
Current	$I_{E6}$	–	–	mA	internally limited
<b>GND</b>					
Current	$I_{GND}$	-0.5	–	A	–
<b>Temperatures</b>					
Junction temperature	$T_J$	–	150	$^\circ\text{C}$	–
Storage temperature	$T_{stg}$	-50	150	$^\circ\text{C}$	–



**Table 4 Operating Range**

Parameter	Symbol	Limit Values		Unit	Notes
		Min.	Max.		
Input voltage	$V_I$	5.5	40	V	see diagram
Junction temperature	$T_J$	-40	150	°C	–

**Thermal Resistance**

Junction ambient	$R_{thja}$	–	65	K/W	PG-TO220-7-4 package
Junction-case	$R_{thjc}$	–	6	K/W	PG-TO220-7-4 package
Junction-case	$Z_{thjc}$	–	2	K/W	$T < 1$ ms PG-TO220-7-4 package
Junction ambient	$R_{thja}$	–	70	K/W	PG-TO263-7-1 (SMD) package
Junction-case	$R_{thjc}$	–	6	K/W	PG-TO263-7-1 (SMD) package
Junction-case	$Z_{thjc}$	–	2	K/W	$T < 1$ ms PG-TO263-7-1 (SMD) package

**Table 5 Characteristics**
 $V_1 = 13.5 \text{ V}; -40 \text{ }^\circ\text{C} < T_J < 125 \text{ }^\circ\text{C}; V_{E2} > 4 \text{ V}$  (unless specified otherwise)

Parameter	Symbol	Limit Values			Unit	Test Condition
		Min.	Typ.	Max.		
Output voltage	$V_Q$	4.9	5	5.1	V	$5 \text{ mA} \leq I_Q \leq 400 \text{ mA}$ $6 \text{ V} \leq V_1 \leq 26 \text{ V}$
Output voltage	$V_Q$	4.9	5	5.1	V	$5 \text{ mA} \leq I_Q \leq 150 \text{ mA}$ $6 \text{ V} \leq V_1 \leq 40 \text{ V}$
Output current limiting	$I_Q$	500	–	–	mA	$T_J = 25 \text{ }^\circ\text{C}$
Current consumption $I_q = I_1 - I_Q$	$I_q$	–	–	50	$\mu\text{A}$	IC turned off
Current consumption $I_q = I_1 - I_Q$	$I_q$	–	1.0	10	$\mu\text{A}$	$T_J = 25 \text{ }^\circ\text{C}$ IC turned off
Current consumption $I_q = I_1 - I_Q$	$I_q$	–	1.3	4	mA	$I_Q = 5 \text{ mA}$ IC turned on
Current consumption $I_q = I_1 - I_Q$	$I_q$	–	–	60	mA	$I_Q = 400 \text{ mA}$
Current consumption $I_q = I_1 - I_Q$	$I_q$	–	–	80	mA	$I_Q = 400 \text{ mA}$ $V_1 = 5 \text{ V}$
Drop voltage	$V_{Dr}$	–	0.3	0.6	V	$I_Q = 400 \text{ mA}^{1)}$
Load regulation	$\Delta V_Q$	–	–	50	mV	$5 \text{ mA} \leq I_Q \leq 400 \text{ mA}$
Supply-voltage regulation	$\Delta V_Q$	–	15	25	mV	$V_1 = 6$ to $36 \text{ V};$ $I_Q = 5 \text{ mA}$
Supply-voltage rejection	$SVR$	–	54	–	dB	$f_r = 100 \text{ Hz};$ $V_r = 0.5 \text{ V}_{pp}$
Longterm stability	$\Delta V_Q$	–	0	–	mV	1000 h
<b>Reset Generator</b>						
Switching threshold	$V_{RT}$	4.5	4.65	4.8	V	$V_Q$ decreasing
Reset High level	–	4.5	–	–	V	$R_{ext} = \infty$
Saturation voltage	$V_{RO,SAT}$	–	0.1	0.4	V	$R_R = 4.7 \text{ k}\Omega^{2)}$
Internal Pull-up resistor	$R_{RO}$	–	30	–	$\text{k}\Omega$	–
Saturation voltage	$V_{D,SAT}$	–	50	100	mV	$V_Q < V_{RT}$
Charge current	$I_D$	8	15	25	$\mu\text{A}$	$V_D = 1.5 \text{ V}$
Upper delay switching threshold	$V_{UD}$	2.6	3	3.3	V	–

**Table 5 Characteristics (cont'd)**
 $V_I = 13.5 \text{ V}; -40 \text{ }^\circ\text{C} < T_J < 125 \text{ }^\circ\text{C}; V_{E2} > 4 \text{ V}$  (unless specified otherwise)

Parameter	Symbol	Limit Values			Unit	Test Condition
		Min.	Typ.	Max.		
Delay time	$t_D$	–	20	–	ms	$C_d = 100 \text{ nF}$
Lower delay switching threshold	$V_{LD}$	–	0.43	–	V	–
Reset reaction time	$t_{RR}$	–	2	–	$\mu\text{s}$	$C_d = 100 \text{ nF}$

**Inhibit**

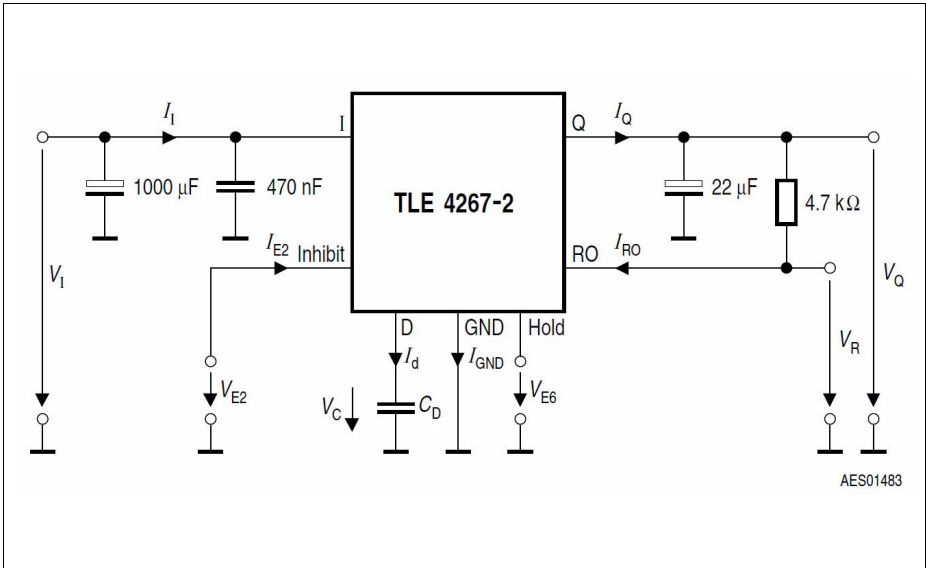
Turn on voltage	$V_{U,INH}$	–	3	4	V	IC turned on
Turn off voltage	$V_{L,INH}$	2	–	–	V	IC turned off
Pull-down resistor	$R_{INH}$	50	100	200	$\text{k}\Omega$	–
Hysteresis	$\Delta V_{INH}$	0.2	0.5	0.8	V	–
Input current	$I_{INH}$	–	35	100	$\mu\text{A}$	$V_{INH} = 4 \text{ V}$
Hold voltage	$V_{U,HOLD}$	30	35	40	%	Referred to $V_Q$
Turn off voltage	$V_{L,HOLD}$	60	70	80	%	Referred to $V_Q$
Pull-up resistor	$R_{HOLD}$	20	50	100	$\text{k}\Omega$	–

**Overvoltage Protection**

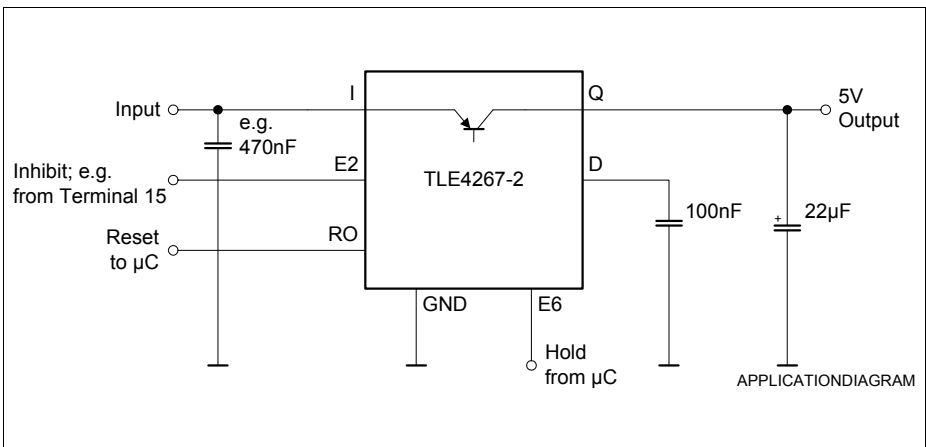
Turn off voltage	$V_{I,OV}$	42	44	46	V	$V_I$ increasing
Turn on voltage	$V_{I,turn\ on}$	36	–	–	V	$V_I$ decreasing after turn off

1) Drop voltage =  $V_I - V_Q$  (measured when the output voltage  $V_Q$  has dropped 100 mV from the nominal value obtained at  $V_I = 13.5 \text{ V}$ )

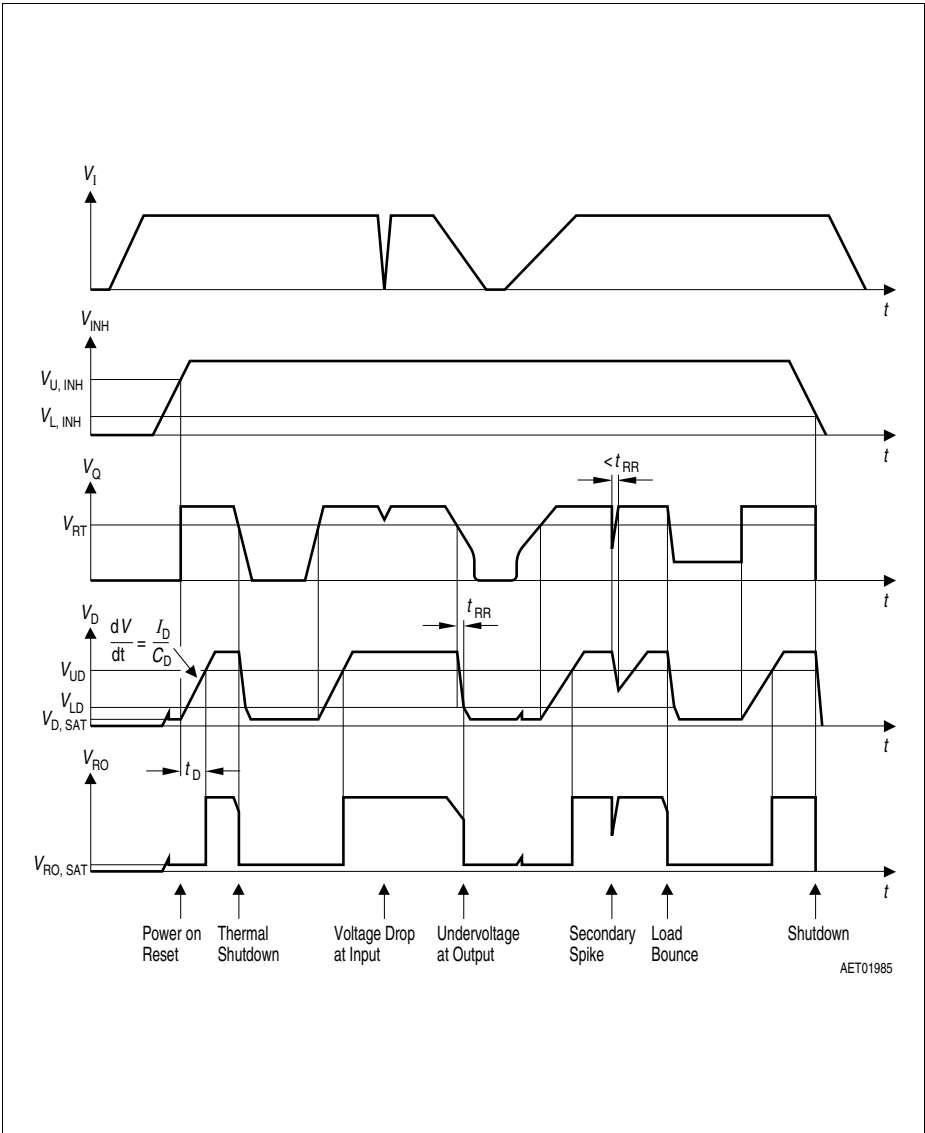
2) The reset output is Low for  $1 \text{ V} < V_Q < V_{RT}$



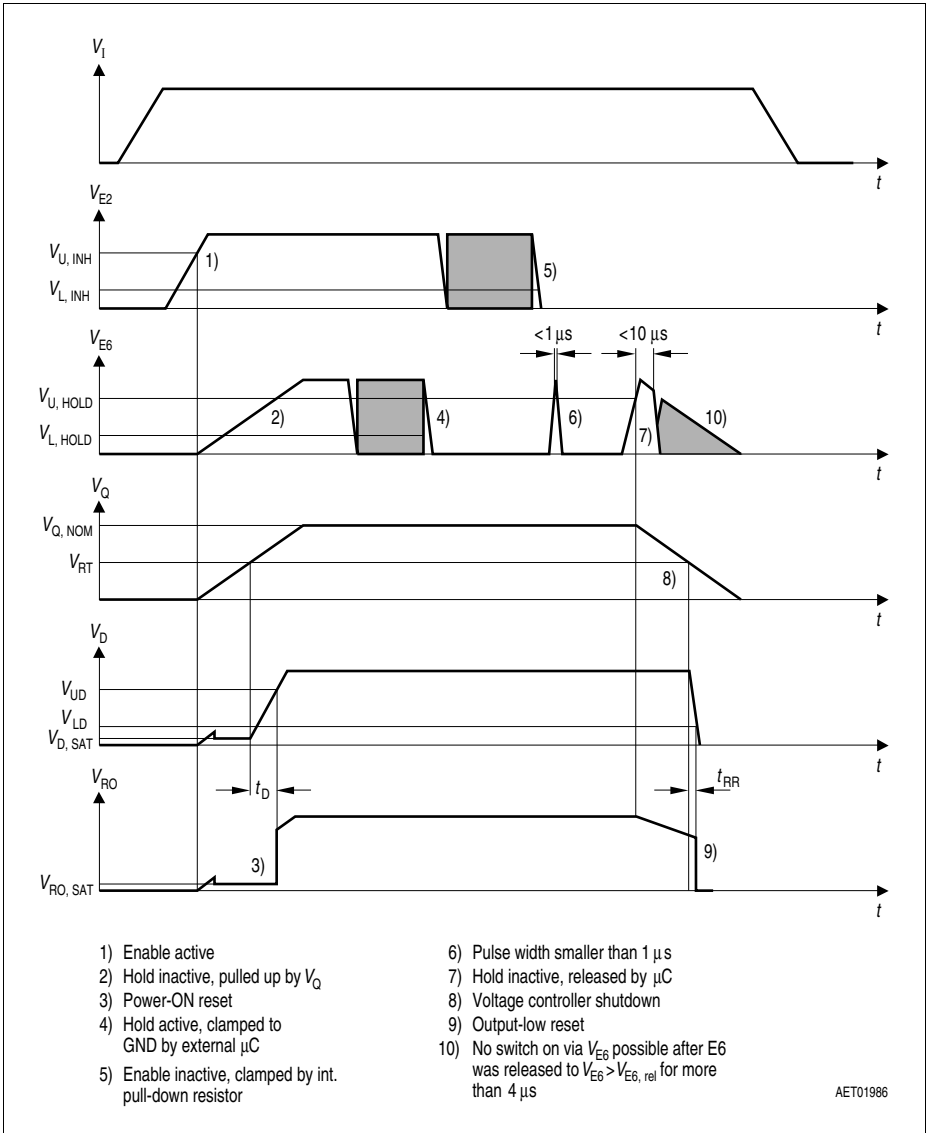
**Figure 3 Test Circuit**



**Figure 4 Application Circuit**

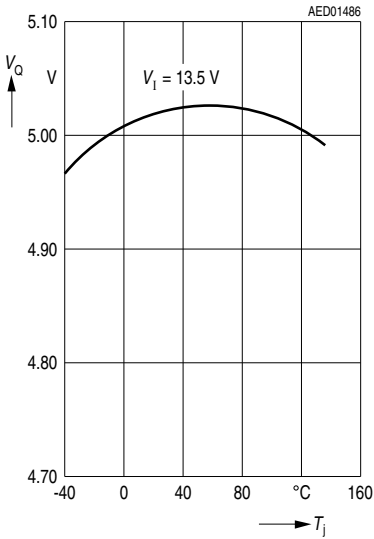


**Figure 5 Time Response**

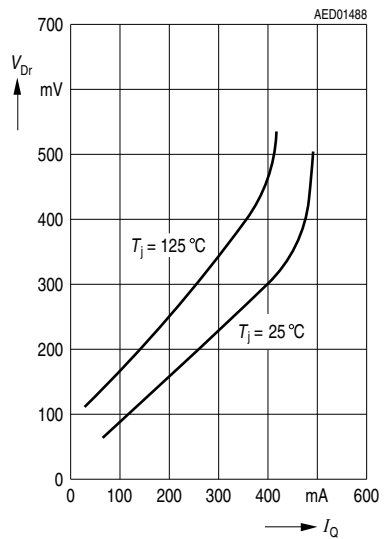


**Figure 6 Enable and Hold Behavior**

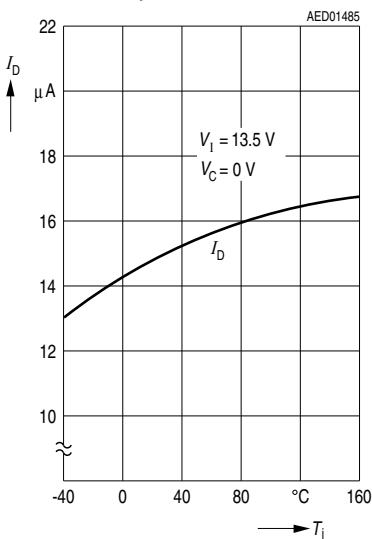
**Output Voltage  $V_Q$  versus Temperature  $T_j$**



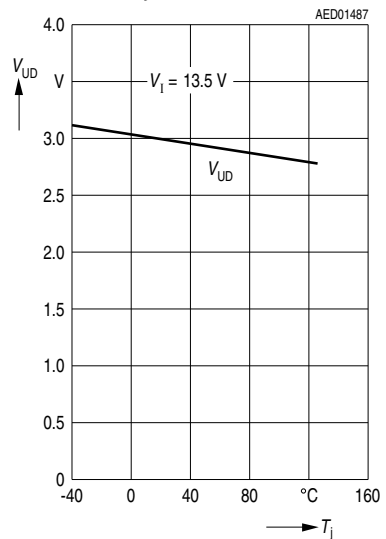
**Drop Voltage  $V_{Dr}$  versus Output Current  $I_Q$**



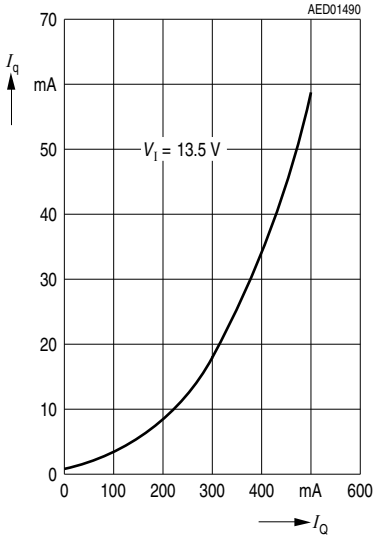
**Charge Current  $I_D$  versus Temperature  $T_j$**



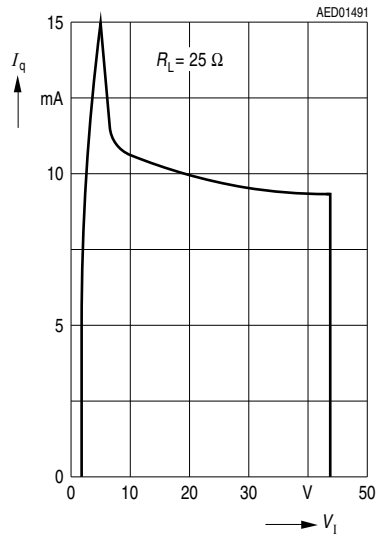
**Delay Switching Threshold  $V_{UD}$  versus Temperature  $T_j$**



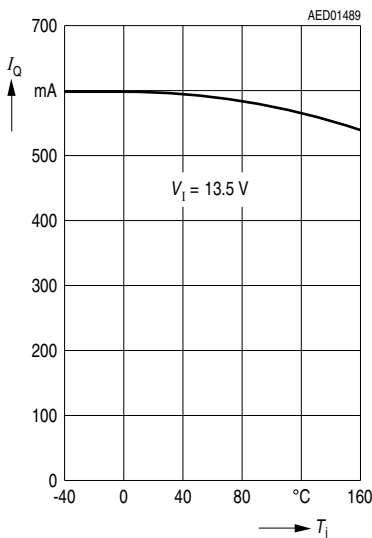
**Current Consumption  $I_q$  versus Output Current  $I_Q$**



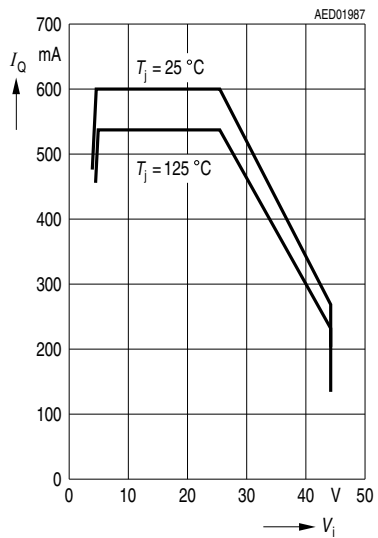
**Current Consumption  $I_q$  versus Input Voltage  $V_i$**



**Output Current Limiting  $I_Q$  versus Temperature  $T_j$**

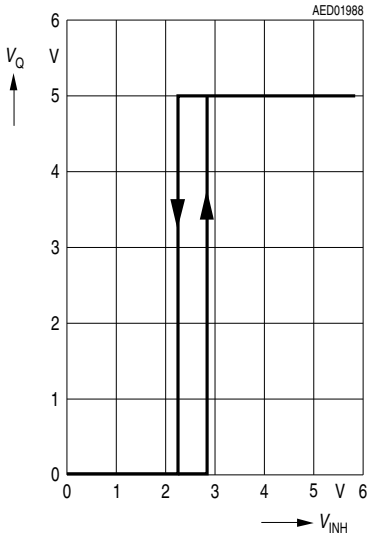


**Output Current Limiting  $I_Q$  versus Input Voltage  $V_i$**

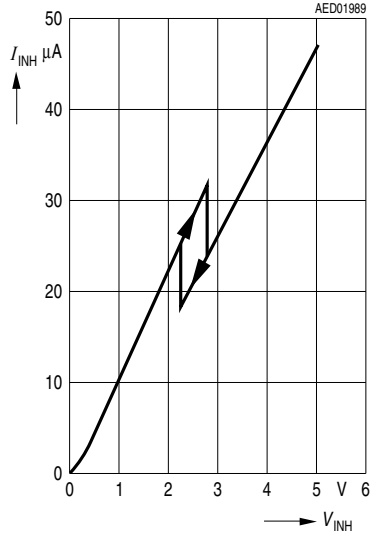




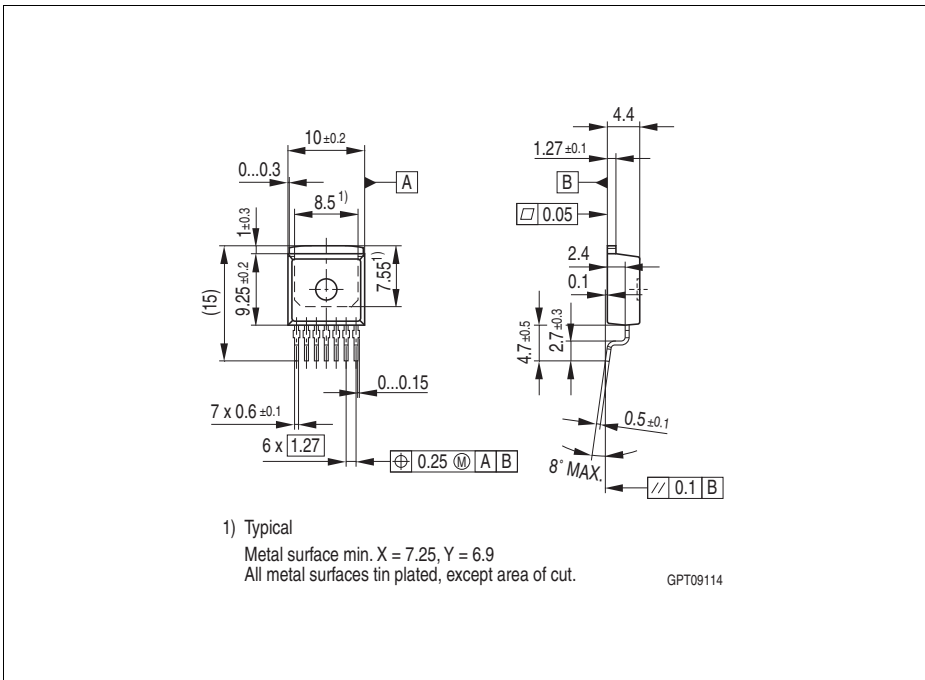
**Output Voltage  $V_Q$  versus  
Inhibit Voltage  $V_{INH}$**



**Inhibit Current  $I_{INH}$  versus  
Inhibit Voltage  $V_{INH}$**







**Figure 8 PG-TO263-7-1 (Plastic Transistor Single Outline)**

**Green Product (RoHS compliant)**

[1] To meet the world-wide customer requirements for environmentally friendly products and to be compliant with government regulations the device is available as a green product. Green products are RoHS-Compliant (i.e Pb-free finish on leads and suitable for Pb-free soldering according to IPC/JEDEC J-STD-020).

Find all of our packages, sorts of packing and others in our Infineon Internet Page "Products": <http://www.infineon.com/packages>.

SMD = Surface Mounted Device

Dimensions in mm

**Revision History**

<b>Version</b>	<b>Date</b>	<b>Changes</b>
Rev. 1.0	2012-04-03	Initial datasheet for TLE4267-2

**Edition 2012-04-03**

**Published by  
Infineon Technologies AG  
81726 Munich, Germany**

**© 2012 Infineon Technologies AG  
All Rights Reserved.**

#### **Legal Disclaimer**

The information given in this document shall in no event be regarded as a guarantee of conditions or characteristics. With respect to any examples or hints given herein, any typical values stated herein and/or any information regarding the application of the device, Infineon Technologies hereby disclaims any and all warranties and liabilities of any kind, including without limitation, warranties of non-infringement of intellectual property rights of any third party.

#### **Information**

For further information on technology, delivery terms and conditions and prices, please contact the nearest Infineon Technologies Office ([www.infineon.com](http://www.infineon.com)).

#### **Warnings**

Due to technical requirements, components may contain dangerous substances. For information on the types in question, please contact the nearest Infineon Technologies Office.

Infineon Technologies components may be used in life-support devices or systems only with the express written approval of Infineon Technologies, if a failure of such components can reasonably be expected to cause the failure of that life-support device or system or to affect the safety or effectiveness of that device or system. Life support devices or systems are intended to be implanted in the human body or to support and/or maintain and sustain and/or protect human life. If they fail, it is reasonable to assume that the health of the user or other persons may be endangered.