



Chipsmall Limited consists of a professional team with an average of over 10 year of expertise in the distribution of electronic components. Based in Hongkong, we have already established firm and mutual-benefit business relationships with customers from,Europe,America and south Asia,supplying obsolete and hard-to-find components to meet their specific needs.

With the principle of “Quality Parts,Customers Priority,Honest Operation,and Considerate Service”,our business mainly focus on the distribution of electronic components. Line cards we deal with include Microchip,ALPS,ROHM,Xilinx,Pulse,ON,Everlight and Freescale. Main products comprise IC,Modules,Potentiometer,IC Socket,Relay,Connector.Our parts cover such applications as commercial,industrial, and automotives areas.

We are looking forward to setting up business relationship with you and hope to provide you with the best service and solution. Let us make a better world for our industry!



Contact us

Tel: +86-755-8981 8866 Fax: +86-755-8427 6832

Email & Skype: info@chipsmall.com Web: www.chipsmall.com

Address: A1208, Overseas Decoration Building, #122 Zhenhua RD., Futian, Shenzhen, China



TLE4906H TLE4906L

High Precision Hall-Effect Switch

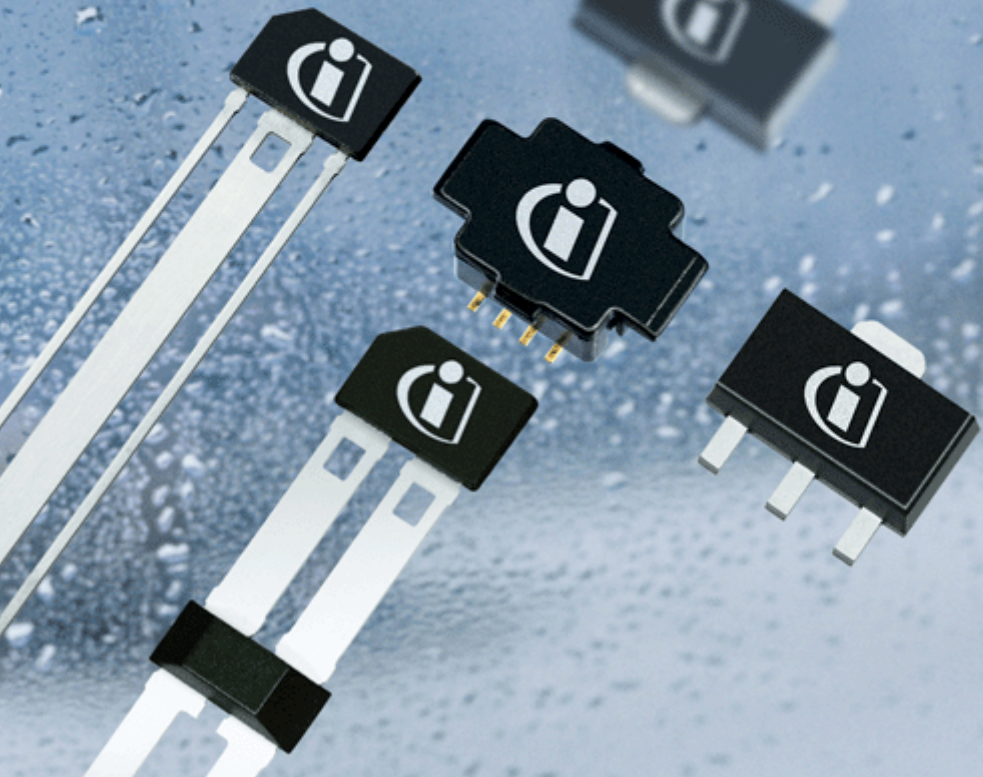

Sensors



Never stop thinking

Edition 2005-10

**Published by Infineon Technologies AG,
St.-Martin-Strasse 53,
81669 München, Germany**

**© Infineon Technologies AG 2005.
All Rights Reserved.**

Attention please!

The information given in this document shall in no event be regarded as a guarantee of conditions or characteristics ("Beschaffenheitsgarantie"). With respect to any examples or hints given herein, any typical values stated herein and/or any information regarding the application of the device, Infineon Technologies hereby disclaims any and all warranties and liabilities of any kind, including without limitation warranties of non-infringement of intellectual property rights of any third party.

Information

For further information on technology, delivery terms and conditions and prices please contact your nearest Infineon Technologies Office (www.infineon.com).

Warnings

Due to technical requirements components may contain dangerous substances. For information on the types in question please contact your nearest Infineon Technologies Office.

Infineon Technologies Components may only be used in life-support devices or systems with the express written approval of Infineon Technologies, if a failure of such components can reasonably be expected to cause the failure of that life-support device or system, or to affect the safety or effectiveness of that device or system. Life support devices or systems are intended to be implanted in the human body, or to support and/or maintain and sustain and/or protect human life. If they fail, it is reasonable to assume that the health of the user or other persons may be endangered.

TLE4906H

TLE4906L

Revision History: **2005-10**

V 1.1

Previous Version: 1.0

Page	Subjects (major changes since last revision)
6	Figure 1 Correction of dimensions for package PG-SSO-3-2
14	Figure 6 Correction of dimensions
15	Figure 9 Correction of dimensions
16	Figure 10 Correction of dimensions

We Listen to Your Comments

Any information within this document that you feel is wrong, unclear or missing at all?
Your feedback will help us to continuously improve the quality of this document.
Please send your proposal (including a reference to this document) to:

feedback.sensors@infineon.com



1	Overview	5
1.1	Features	5
1.2	Functional Description	5
1.3	Pin Configuration (top view)	6
2	General	7
2.1	Block Diagram	7
2.2	Circuit Description	7
3	Maximum Ratings	8
4	Operating Range	9
5	Electrical and Magnetic Parameters	10
	Field Direction Definion	11
6	Timing Diagram	12
7	Package Information	13
7.1	Package Marking	13
7.2	Distance between Chip and Package Surface	14
7.3	Package Outlines	15
	PCB Footprint for SC59	15

1 Overview

1.1 Features

- 2.7 V to 24 V supply voltage operation
- Operation from unregulated power supply
- High sensitivity and high stability of the magnetic switching points
- High resistance to mechanical stress by Active Error Compensation
- Reverse battery protection (– 18 V)
- Superior temperature stability
- Peak temperatures up to 195°C without damage
- Low jitter (typ. 1 μ s)
- High ESD performance (\pm 6 kV HBM)
- Digital output signal
- SMD package SC59 (SOT23 compatible) - (TLE4906H))
- Leaded package PG-SSO-3-2 - (TLE4906L)

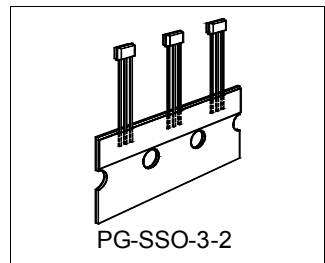
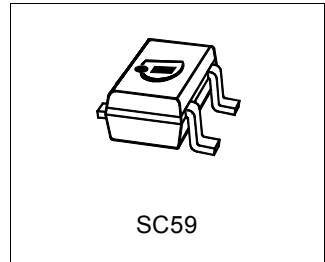

1.2 Functional Description

The TLE4906H and the TLE4906L are integrated circuit Hall-effect sensors designed specifically for highly accurate applications.

Precise magnetic switching points and high temperature stability are achieved by active compensation circuits and chopper techniques on chip.

Type	Package
TLE4906H	SC59
TLE4906L	PG-SSO-3-2

1.3 Pin Configuration (top view)

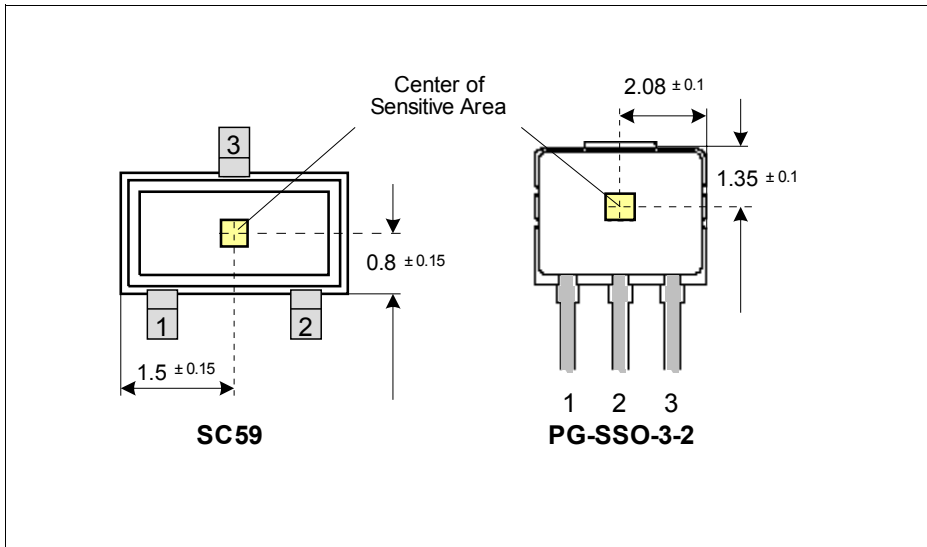

Figure 1 Pin Definition and Center of Sensitive Area

Table 1 Pin Definitions and Functions SC59

Pin No.	Symbol	Function
1	V_S	Supply voltage
2	Q	Output
3	GND	Ground

Table 2 Pin Definitions and Functions PG-SSO-3-2

Pin No.	Symbol	Function
1	V_S	Supply voltage
2	GND	Ground
3	Q	Output

2 General

2.1 Block Diagram

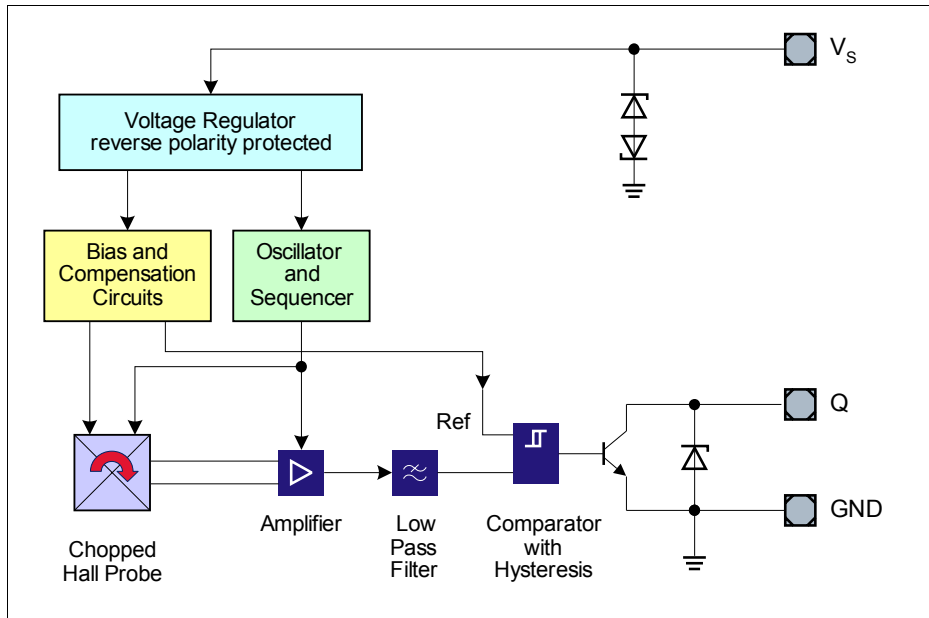

Figure 2 Block Diagram

2.2 Circuit Description

The chopped Hall IC Switch comprises a Hall probe, bias generator, compensation circuits, oscillator, and output transistor.

The bias generator provides currents for the Hall probe and the active circuits. Compensation circuits stabilize the temperature behavior and reduce technology variations.

The Active Error Compensation rejects offsets in signal stages and the influence of mechanical stress to the Hall probe caused by molding and soldering processes and other thermal stresses in the package.

This chopper technique together with the threshold generator and the comparator ensure high accurate magnetic switching points.

3 Maximum Ratings

Table 3 Absolute Maximum Ratings

$$T_j = -40^{\circ}\text{C to } 150^{\circ}\text{C}$$

Parameter	Symbol	Limit Values		Unit	Conditions
		min.	max.		
Supply voltage	V_S	- 18 - 18 - 18	18 24 26	V	for 1 h, $R_s \geq 200 \Omega$ for 5 min, $R_s \geq 200 \Omega$
Supply current through protection device	I_S	- 50	+ 50	mA	
Output voltage	V_Q	- 0.7 - 0.7	18 26	V	for 5 min @ 1.2 k Ω pull up
Continuous output current	I_Q	- 50	+ 50	mA	
Junction temperature	T_j	- - - -	155 165 175 195	$^{\circ}\text{C}$	for 2000 h (not additive) for 1000 h (not additive) for 168 h (not additive) for 3 x 1 h (additive)
Storage temperature	T_S	- 40	150	$^{\circ}\text{C}$	
Magnetic flux density	B	-	unlimited	mT	

Note: Stresses above those listed here may cause permanent damage to the device. Exposure to absolute maximum rating conditions for extended periods may affect device reliability.

Table 4 ESD Protection ¹⁾

Parameter	Symbol	Limit Values		Unit	Notes
		min.	max.		
ESD voltage	V_{ESD}	-	± 6	kV	HBM, $R = 1.5 \text{ k}\Omega$, $C = 100 \text{ pF}$ $T_A = 25^{\circ}\text{C}$

1) Human Body Model (HBM) tests according to: EOS/ESD Association Standard S5.1-1993 and Mil. Std. 883D method 3015.7

4 Operating Range

Table 5 Operating Range

Parameter	Symbol	Limit Values			Unit	Conditions
		min.	typ.	max.		
Supply voltage	V_S	2.7	–	18	V	
Output voltage	V_Q	– 0.7	–	18	V	
Junction temperature	T_j	– 40	–	150	°C	
Output current	I_Q	0	–	20	mA	

5 Electrical and Magnetic Parameters

Table 6 Electrical Characteristics ¹⁾.

Parameter	Symbol	Limit Values			Unit	Conditions
		min.	typ.	max.		
Supply current	I_S	2	4	6	mA	$V_S = 2.7\text{ V} \dots 18\text{ V}$
Reverse current	I_{SR}	0	0.2	1	mA	$V_S = -18\text{ V}$
Output saturation voltage	V_{QSAT}	–	0.3	0.6	V	$I_Q = 20\text{ mA}$
Output leakage current	I_{QLEAK}	–	0.05	10	μA	for $V_Q = 18\text{ V}$
Output fall time	t_f	–	0.02	1	μs	$R_L = 1.2\text{ k}\Omega$; $C_L = 50\text{ pF}$ see: Figure 3 “Timing Definition” on Page 12
Output rise time	t_r	–	0.4	1	μs	
Chopper frequency	f_{OSC}	–	320	–	kHz	
Switching frequency	f_{SW}	0	–	15 ²⁾	kHz	
Delay time ³⁾	t_d	–	13	–	μs	
Output jitter ⁴⁾	t_{QJ}	–	1	–	μs_{RMS}	Typical value for square wave signal 1 kHz
Power-on time ⁵⁾	t_{PON}	–	13	–	μs	$V_S \geq 2.7\text{ V}$
Thermal resistance ⁶⁾	R_{thJA}	–	100	–	K/W	SC59
		–	–	190		PG-SSO-3-2

1) over operating range, unless otherwise specified. Typical values correspond to $V_S = 12\text{ V}$ and $T_A = 25^\circ\text{C}$

2) To operate the sensor at the max. switching frequency, the value of the magnetic signal amplitude must be 1.4 times higher than for static fields.

This is due to the - 3 dB corner frequency of the low pass filter in the signal path.

3) Systematic delay between magnetic threshold reached and output switching

4) Jitter is the unpredictable deviation of the output switching delay

5) Time from applying $V_S \geq 2.7\text{ V}$ to the sensor until the output state is valid

6) Thermal resistance from junction to ambient

Calculation of the ambient temperature (SC59 example)

e.g. for $V_S = 12.0\text{ V}$, $I_{Styp} = 4\text{ mA}$, $V_{QSATtyp} = 0.3\text{ V}$ and $I_Q = 20\text{ mA}$:

Power Dissipation: $P_{DIS} = 54.0\text{ mW}$.

In $T_A = T_j - (R_{thJA} \times P_{DIS}) = 175^\circ\text{C} - (100\text{ K/W} \times 0.054\text{ W})$

Resulting max. ambient temperature: $T_A = 169.6^\circ\text{C}$

Electrical and Magnetic Parameters
Table 7 Magnetic Characteristics TLE4906H and TLE4906L¹⁾

Parameter	Symbol	T_j [°C]	Limit Values			Unit	Notes
			min.	typ.	max.		
Operate point	B_{OP}	- 40	6.7	10.3	13.9	mT	
		25	6.5	10.0	13.5		
		150	6.2	9.5	12.9		
Release point	B_{RP}	- 40	5.2	8.7	12.3	mT	
		25	5.0	8.5	12.0		
		150	4.7	8.1	11.4		
Hysteresis	B_{HYS}	- 40	–	–	–	mT	
		25	0.7	1.5	3.0		
		150	–	–	–		
Temperature compensation of magnetic thresholds	TC	–	–	- 350	–	ppm/°C	
Repeatability of magnetic thresholds ²⁾	B_{REP}		–	20	–	μT_{RMS}	Typ. value for $\Delta B / \Delta t > 12$ mT/ms

1) over operating range, unless otherwise specified. Typical values correspond to $V_S = 12$ V.

2) B_{REP} is equivalent to the noise constant

Note: Typical characteristics specify mean values expected over the production spread.

Field Direction Definition

Positive magnetic fields related with south pole of magnet to the branded side of package.

6 Timing Diagram

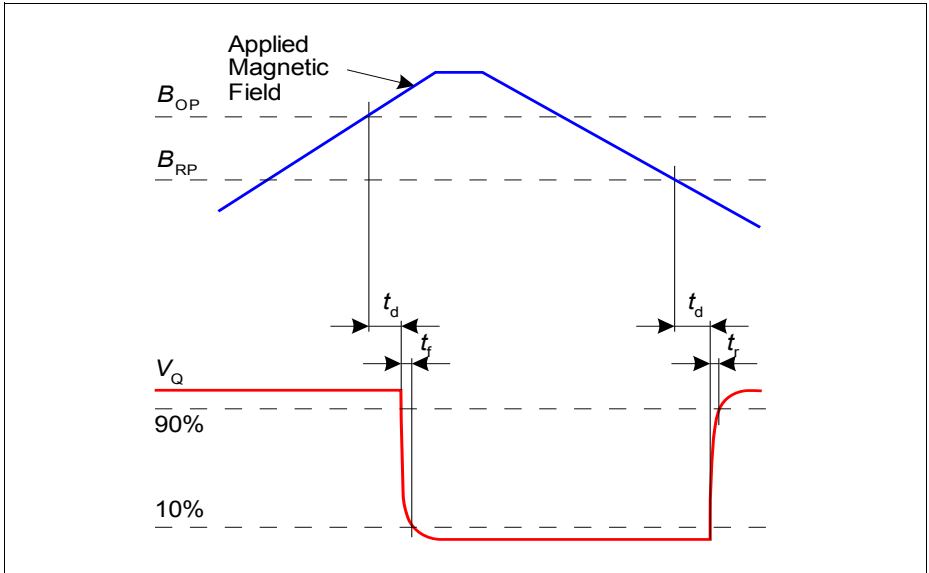

Figure 3 Timing Definition

7 Package Information

7.1 Package Marking

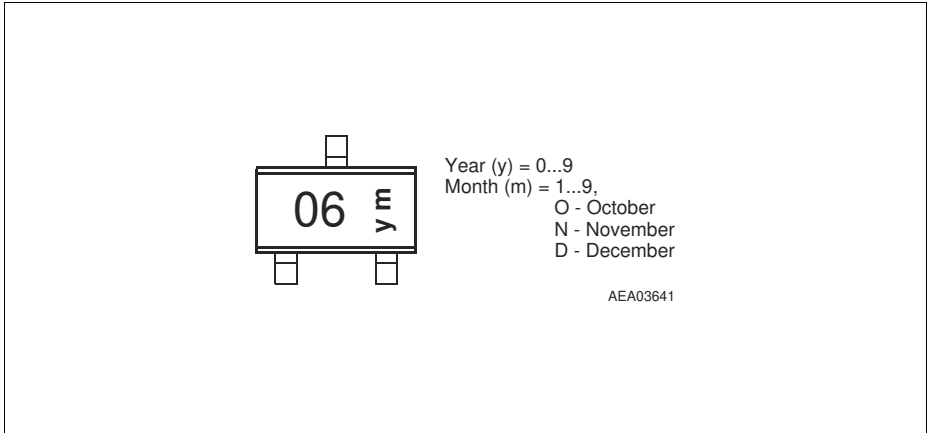

Figure 4 Marking TLE4906H

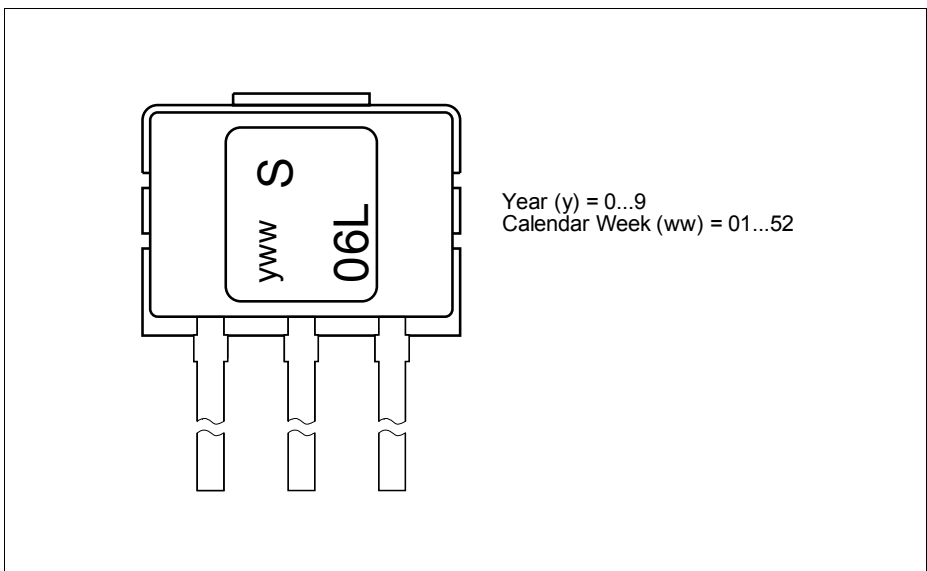

Figure 5 Marking TLE4906L

7.2 Distance between Chip and Package Surface

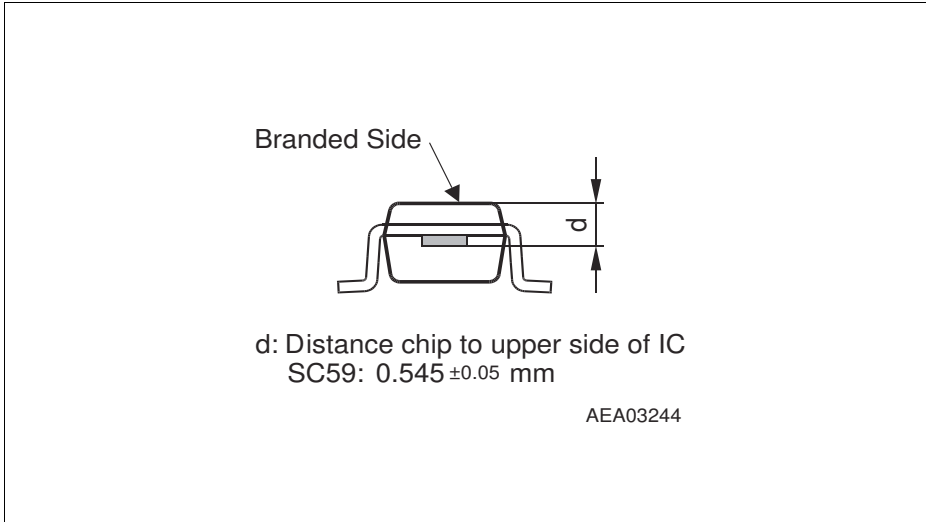

Figure 6 Distance Chip SC59 to Upper Side of IC

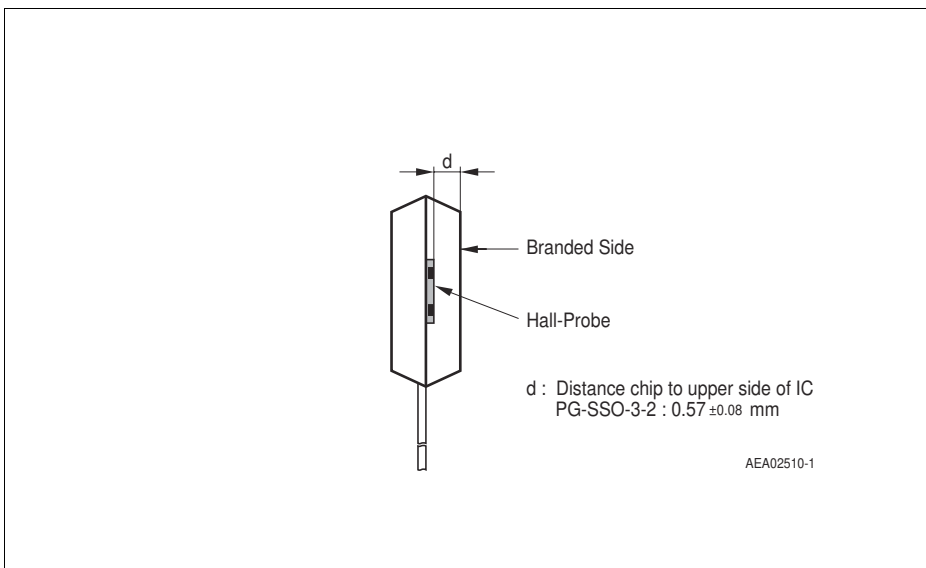

Figure 7 Distance Chip PG-SSO-3-2 to Upper Side of IC

7.3 Package Outlines

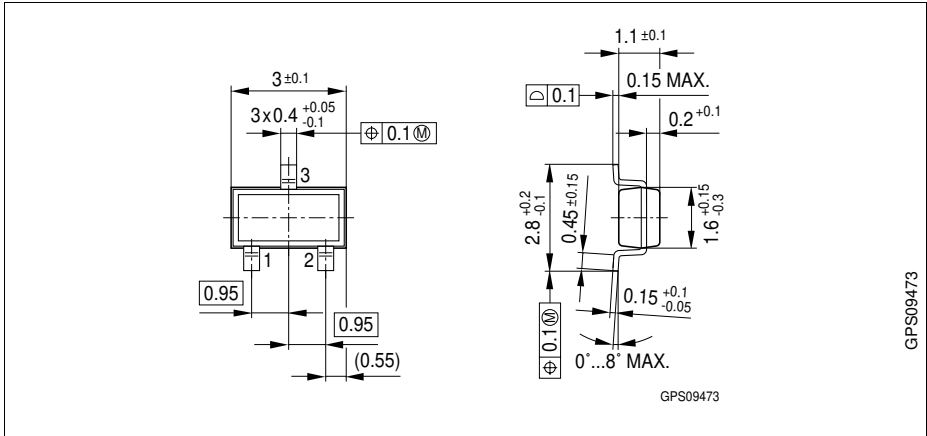

Figure 8 SC59

PCB Footprint for SC59

The following picture shows a recommendation for the PCB layout.

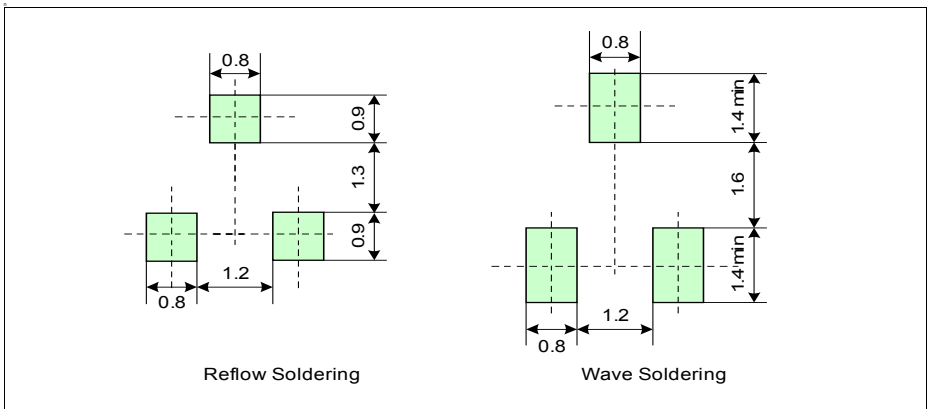

Figure 9 Footprint SC59 (SOT23 compatible)

www.infineon.com

Published by Infineon Technologies AG