



Chipsmall Limited consists of a professional team with an average of over 10 year of expertise in the distribution of electronic components. Based in Hongkong, we have already established firm and mutual-benefit business relationships with customers from,Europe,America and south Asia,supplying obsolete and hard-to-find components to meet their specific needs.

With the principle of “Quality Parts,Customers Priority,Honest Operation,and Considerate Service”,our business mainly focus on the distribution of electronic components. Line cards we deal with include Microchip,ALPS,ROHM,Xilinx,Pulse,ON,Everlight and Freescale. Main products comprise IC,Modules,Potentiometer,IC Socket,Relay,Connector.Our parts cover such applications as commercial,industrial, and automotives areas.

We are looking forward to setting up business relationship with you and hope to provide you with the best service and solution. Let us make a better world for our industry!



Contact us

Tel: +86-755-8981 8866 Fax: +86-755-8427 6832

Email & Skype: info@chipsmall.com Web: www.chipsmall.com

Address: A1208, Overseas Decoration Building, #122 Zhenhua RD., Futian, Shenzhen, China



High Precision Automotive Hall Effect Latch for 5V Applications

TLE4963-1M

SP000930182

Hall Effect Latch

Data Sheet

Revision 1.0, 2016-01-12

Sense & Control

Table of Contents

1	Product Description	5
1.1	Overview	5
1.2	Features	5
1.3	Target Applications	5
2	Functional Description	6
2.1	General	6
2.2	Pin Configuration (top view)	6
2.3	Pin Description	6
2.4	Block Diagram	7
2.5	Functional Block Description	7
2.6	Default Start-up Behavior	9
3	Specification	10
3.1	Application Circuit	10
3.2	Absolute Maximum Ratings	11
3.3	Operating Range	12
3.4	Electrical and Magnetic Characteristics	12
4	Package Information	14
4.1	Package Outline PG-SOT23-3-15	14
4.2	Footprint PG-SC59-3-5 and PG-SOT23-3-15	14
4.3	Packing Information PG-SOT23-3-15	15
4.4	PG-SOT23-3-15 Distance between Chip and Package	15
4.5	Package Marking	15
5	Revision History	16



List of Tables

Table 1	Ordering Information	5
Table 2	Pin Description PG-SOT23-3-15	6
Table 3	Absolute Maximum Rating Parameters	11
Table 4	ESD Protection (TA = 25°C)	11
Table 5	Operating Conditions Parameters	12
Table 6	General Electrical Characteristics	12
Table 7	Magnetic Characteristics	13

List of Figures

Figure 1	Image of TLE4963-1M in the PG-SOT23-3-15 Package	5
Figure 2	Pin Configuration and Center of Sensitive Area	6
Figure 3	Functional Block Diagram TLE4963-1M	7
Figure 4	Timing Diagram TLE4963-1M	8
Figure 5	Output Signal TLE4963-1M	8
Figure 6	Illustration of the Start-up Behavior of the TLE4963-1M	9
Figure 7	Application Circuit	10
Figure 8	Definition of Magnetic Field Direction PG-SOT23-3-15	13
Figure 9	PG-SOT23-3-15 Package Outline (All Dimensions in mm)	14
Figure 10	Footprint PG-SC59-3-5 and PG-SOT23-3-15	14
Figure 11	Packing of the PG-SOT23-3-15 in a Tape	15
Figure 12	Distance between Chip and Package	15
Figure 13	Marking of TLE4963-1M	15

Product Description

1 Product Description



1.1 Overview

The TLE4963-1M is a high precision Hall effect sensor with a latch characteristic and highly accurate switching thresholds for operating temperatures up to 170°C.

Characteristic	Supply Voltage	Supply Current	Sensitivity	Interface	Temperature
Hall Effect Latch	3.0 ~ 5.5 V	1.5 mA	High B _{OP} : +2.0 mT B _{RP} : -2.0 mT	Open Drain Output	-40°C to 170°C



Figure 1 Image of TLE4963-1M in the PG-SOT23-3-15 Package

1.2 Features

- 3.0 V to 5.5 V operating supply voltage
- Operation from regulated power supply
- Active error compensation
- High stability of magnetic thresholds
- Low jitter (typ. 0.28 μs)
- 4kV ESD (HBM) performance
- Small SMD package PG-SOT23-3-15

1.3 Target Applications

Target applications for the TLE4963-1M Hall switch are all applications which require a high precision Hall Switch with an operating temperature range from -40°C to 170°C.

The magnetic behavior as a latch and switching thresholds of typical 2mT make the device especially suited for the use with a pole wheel for index counting applications e.g. power closing and window lifter or brush less DC motors for commutation.

Table 1 Ordering Information

Product Name	Product Type	Ordering Code	Package
TLE4963-1M	Hall Latch	SP000930182	PG-SOT23-3-15

Functional Description

2 Functional Description

2.1 General

The TLE4963-1M is an integrated Hall effect latch designed specifically for highly accurate applications where the sensor is connected to a regulated power supply voltage in the range of 3.0V to 5.5V. It provides a large operating temperature range and temperature stability of the magnetic thresholds.

2.2 Pin Configuration (top view)

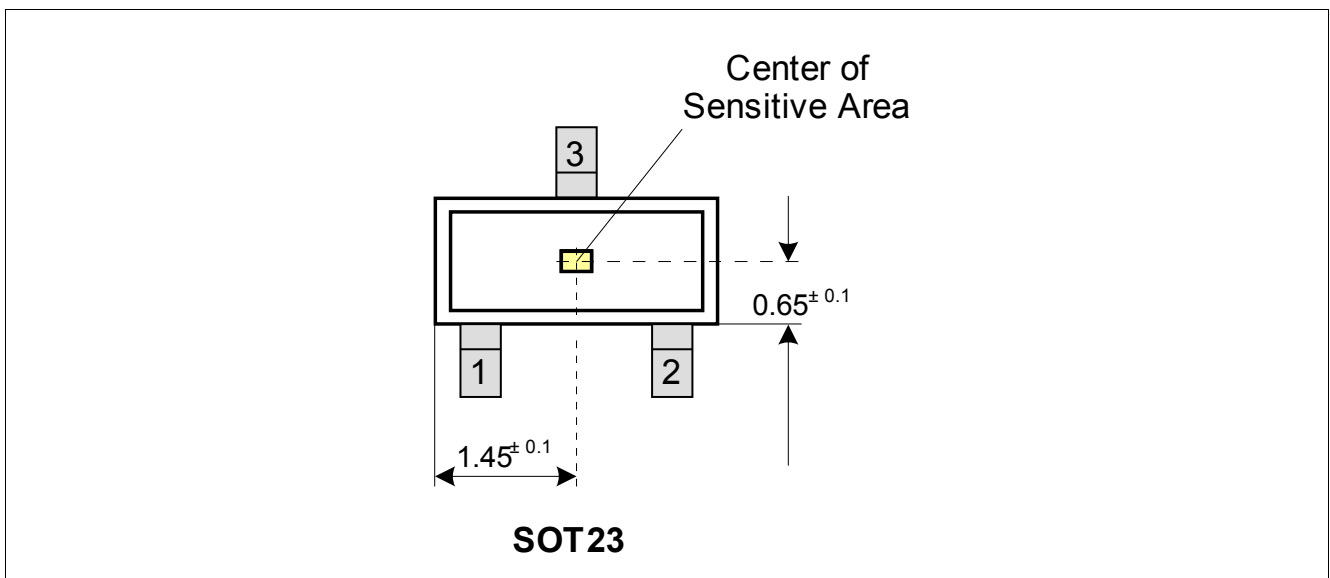

Figure 2 Pin Configuration and Center of Sensitive Area

2.3 Pin Description

Table 2 Pin Description PG-SOT23-3-15

Pin No.	Symbol	Function
1	VDD	Supply voltage
2	Q	Output
3	GND	Ground

Functional Description

2.4 Block Diagram

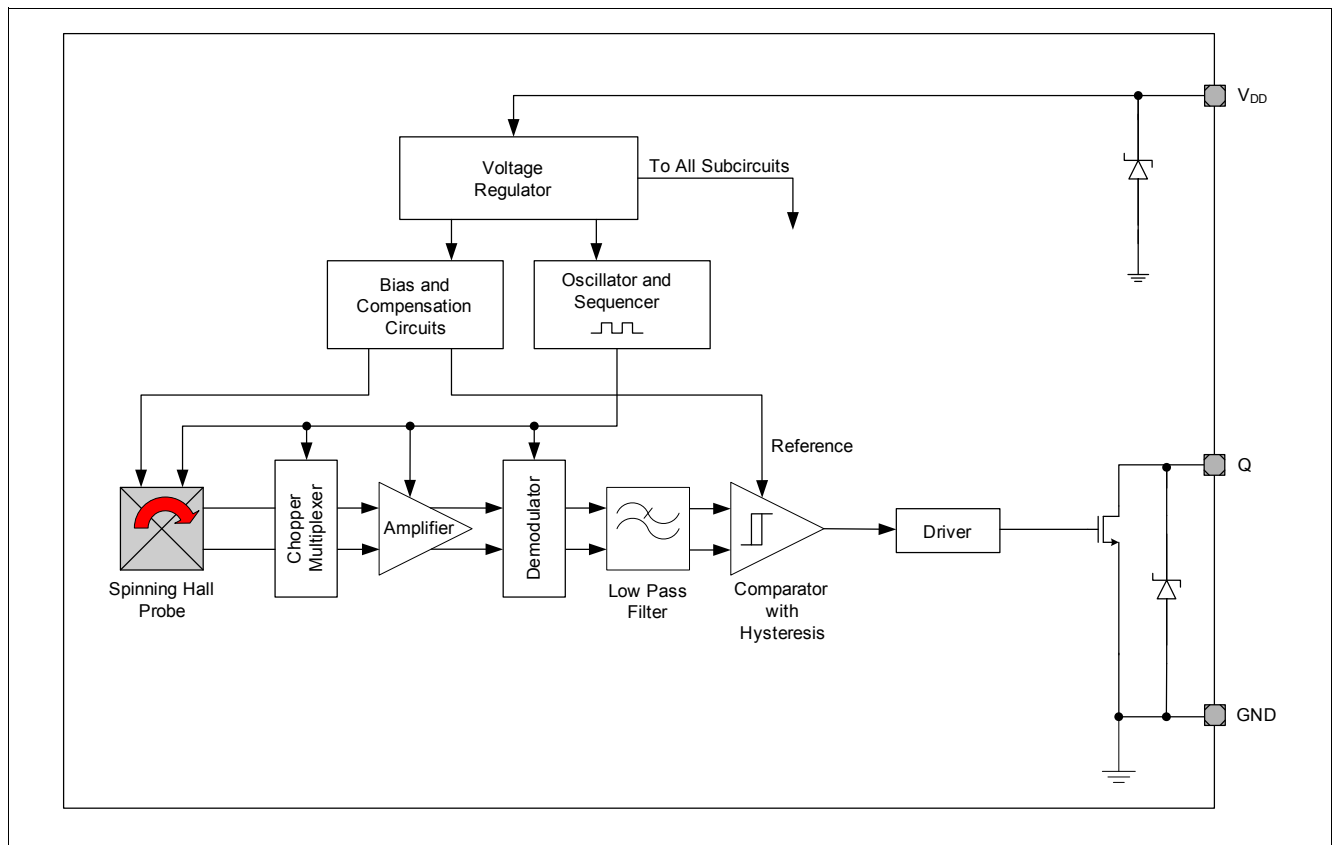

Figure 3 Functional Block Diagram TLE4963-1M

2.5 Functional Block Description

The chopped Hall IC switch comprises a Hall probe, bias generator, compensation circuits, oscillator and output transistor.

The bias generator provides currents for the Hall probe and the active circuits. Compensation circuits stabilize the temperature behavior and reduce influence of technology variations.

The active error compensation (chopping technique) rejects offsets in the signal path and the influence of mechanical stress to the Hall probe caused by molding and soldering processes and other thermal stress in the package. The chopped measurement principle together with the threshold generator and the comparator ensures highly accurate and temperature stable magnetic thresholds.

Functional Description

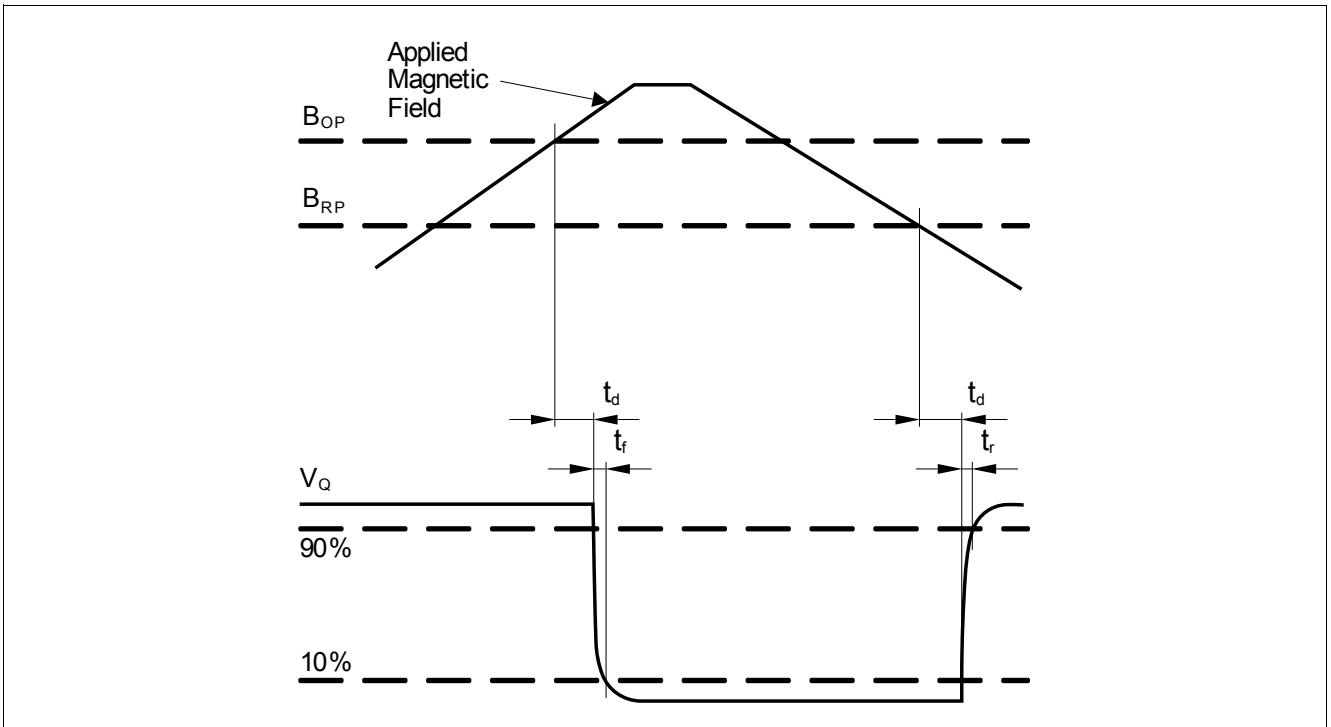

Figure 4 Timing Diagram TLE4963-1M

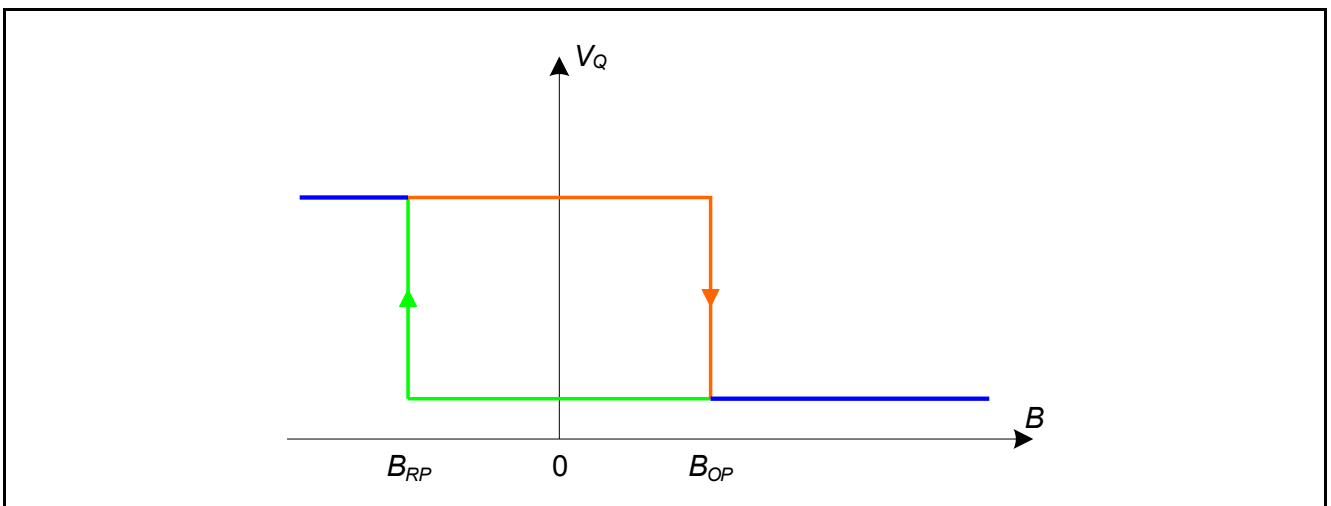

Figure 5 Output Signal TLE4963-1M

Functional Description

2.6 Default Start-up Behavior

The magnetic thresholds exhibit a hysteresis $B_{HYS} = B_{OP} - B_{RP}$. In case of a power-on with a magnetic field B within hysteresis ($B_{OP} > B > B_{RP}$) the output of the sensor is set to the pull up voltage level (V_Q) per default. After the first crossing of B_{OP} or B_{RP} of the magnetic field the internal decision logic is set to the corresponding magnetic input value.

V_{DDA} is the internal supply voltage which is following the external supply voltage V_{DD} .

This means for $B > B_{OP}$ the output is switching, for $B < B_{RP}$ and $B_{OP} > B > B_{RP}$ the output stays at V_Q .

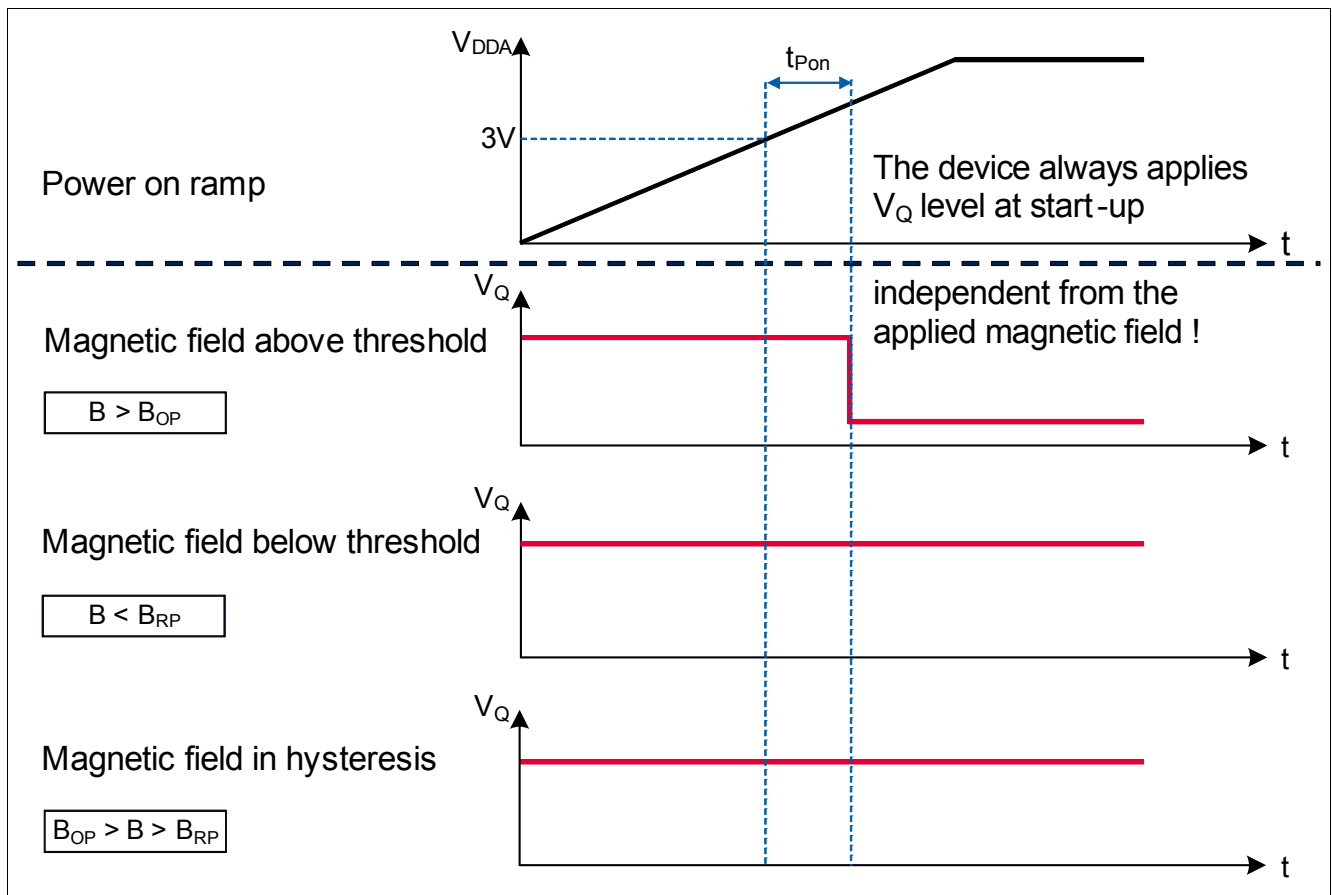

Figure 6 Illustration of the Start-up Behavior of the TLE4963-1M

Specification**3 Specification****3.1 Application Circuit**

The following **Figure 7** shows one option of an application circuit.

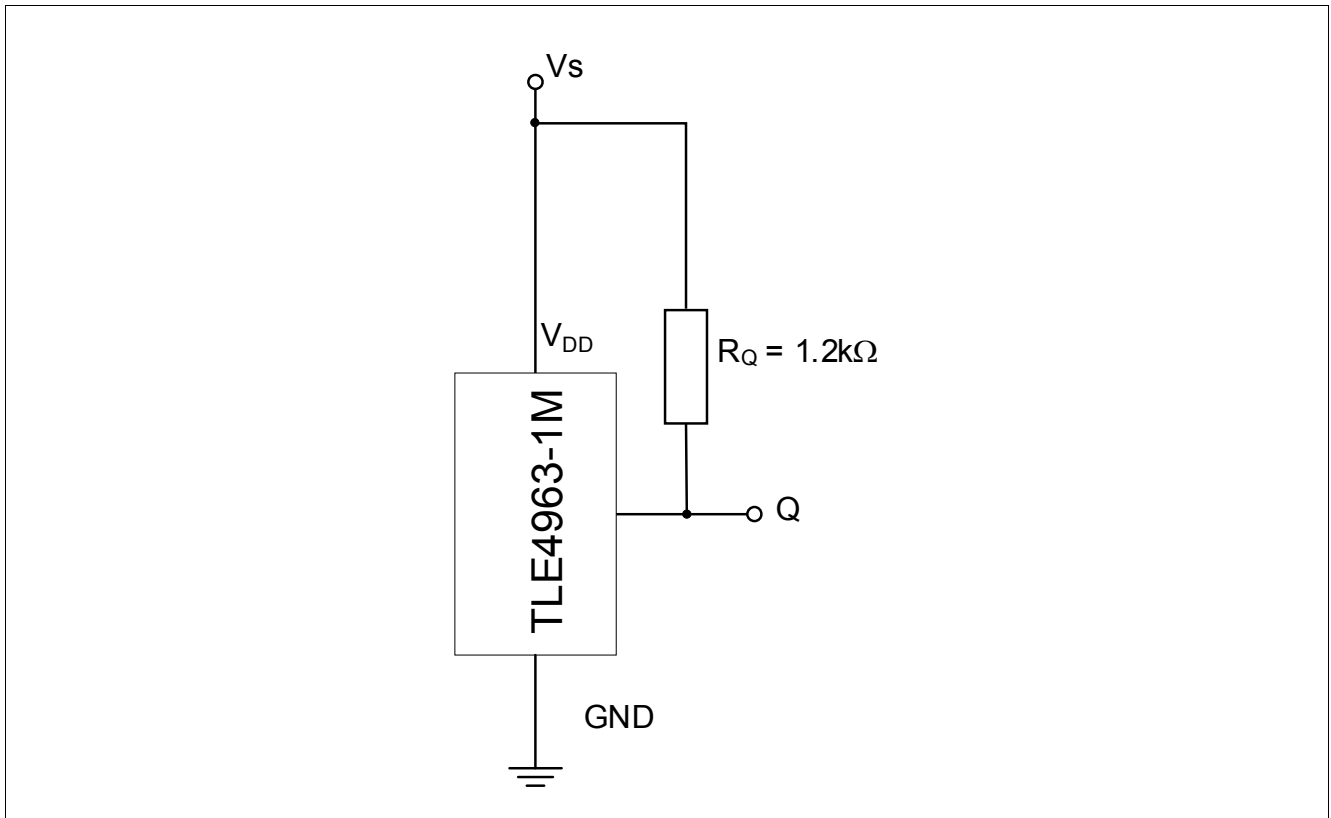

Figure 7 Application Circuit

Specification
3.2 Absolute Maximum Ratings
Table 3 Absolute Maximum Rating Parameters

Parameter	Symbol	Values			Unit	Note or Test Condition
		Min.	Typ.	Max.		
Supply voltage	V_{DD}	-0.3		6	V	
Output voltage	V_Q	-0.5		6	V	
Junction temperature ¹⁾	T_J	-40		155 165 175 195	°C	for 2000h (not additive) for 1000h (not additive) for 168h (not additive) for 3 x 1h (additive)
Thermal resistance Junction ambient	R_{thJA}			300	K/W	for PG-SOT23-3-15 (2s2p)
Thermal resistance Junction lead	R_{thJL}			100	K/W	for PG-SOT23-3-15

1) This lifetime statement is an anticipation based on an extrapolation of Infineon's qualification test results. The actual lifetime of a component depends on its form of application and type of use etc. and may deviate from such statement. The lifetime statement shall in no event extend the agreed warranty period.

Attention: Stresses above the max. values listed here may cause permanent damage to the device. Exposure to absolute maximum rating conditions for extended periods may affect device reliability. Maximum ratings are absolute ratings; exceeding only one of these values may cause irreversible damage to the integrated circuit.

Calculation of the dissipated power P_{DIS} and junction temperature T_J of the chip (SOT23 example):

e.g. for: $V_{DD} = 5\text{ V}$, $I_S = 2\text{ mA}$, $V_{QSAT} = 0.5\text{ V}$, $I_Q = 1\text{ mA}$

Power dissipation: $P_{DIS} = 5\text{ V} \times 2\text{ mA} + 0.5\text{ V} \times 1\text{ mA} = 10\text{ mW} + 0.5\text{ mW} = 10.5\text{ mW}$

Temperature $\Delta T = R_{thJA} \times P_{DIS} = 300\text{ K/W} \times 10.5\text{ mW} = 3.15\text{ K}$

For $T_A = 150\text{ °C}$: $T_J = T_A + \Delta T = 150\text{ °C} + 3.15\text{ K} = 153.15\text{ °C}$

Table 4 ESD Protection¹⁾ ($T_A = 25\text{ °C}$)

Parameter	Symbol	Values			Unit	Note or Test Condition
		Min.	Typ.	Max.		
ESD voltage (HBM) ²⁾	V_{ESD}	-4		4	kV	R = 1.5 k Ω , C = 100 pF
ESD voltage (CDM) ³⁾		-1		1	kV	

1) Characterization of ESD is carried out on a sample basis, not subject to production test.

2) Human Body Model (HBM) tests according to ANSI/ESDA/JEDEC JS-001.

3) Charged Device Model (CDM), ESD susceptibility according to JEDEC JESD22-C101.

Specification

3.3 Operating Range

The following operating conditions must not be exceeded in order to ensure correct operation of the TLE4963-1M.

All parameters specified in the following sections refer to these operating conditions unless otherwise mentioned.

Table 5 Operating Conditions Parameters

Parameter	Symbol	Values			Unit	Note or Test Condition
		Min.	Typ.	Max.		
Supply voltage	V_{DD}	3.0		5.5	V	
Output voltage	V_Q	-0.3		5.5	V	
Junction temperature	T_j	-40		170	°C	
Output current	I_Q	0		5	mA	
Magnetic signal input frequency ¹⁾	f_{SW}	0		10	kHz	

1) For operation at the maximum switching frequency the magnetic input signal must be 1.4 times higher than for static fields. This is due to the -3dB corner frequency of the internal low-pass filter in the signal path.

3.4 Electrical and Magnetic Characteristics

Product characteristics involve the spread of values guaranteed within the specified voltage and ambient temperature range. Typical characteristics are the median of the production and correspond to $V_{DD} = 5\text{ V}$ and $T_A = 25^\circ\text{C}$. The below listed specification is valid in combination with the application circuit shown in [Figure 7](#).

Table 6 General Electrical Characteristics

Parameter	Symbol	Values			Unit	Note or Test Condition
		Min.	Typ.	Max.		
Supply current	I_S	1.1	1.5	2.5	mA	
Reverse current ¹⁾	I_{SR}			2.5	mA	for $V_{DD} = -0.3\text{ V}$ and 170°C
Output saturation voltage	V_{QSAT}		0.2	0.5	V	$I_Q = 5\text{ mA}$
Output leakage current	I_{QLEAK}			10	μA	
Output fall time ¹⁾	t_f	0.17	0.24	1	μs	1.2 k Ω / 50 pF, see Figure 4
Output rise time ¹⁾	t_r	0.4	0.5	1	μs	1.2 k Ω / 50 pF, see Figure 4
Output jitter ¹⁾²⁾	t_{QJ}		0.28	1	μs	For square wave signal with 1 kHz
Delay time ¹⁾³⁾	t_d	11.5	15	30	μs	see Figure 4
Power-on time ¹⁾⁴⁾	t_{PON}		50	100	μs	$V_{DD} = 3\text{ V}$, $B \leq B_{RP} - 0.5\text{ mT}$ or $B \geq B_{OP} + 0.5\text{ mT}$
Chopper frequency ¹⁾	f_{OSC}		350		kHz	

1) Not subject to production test, verified by design/characterization.

2) Output jitter is the 1σ value of the output switching distribution.

Specification

- 3) Systematic delay between magnetic threshold reached and output switching.
- 4) Time from applying $V_{DD} = 3.0\text{ V}$ to the sensor until the output is valid.

Table 7 Magnetic Characteristics

Parameter	Symbol	T (°C)	Values			Unit	Note / Test Condition
			Min.	Typ.	Max.		
Operating point	B_{OP}	-40	0.6	2.2	3.7	mT	
		25	0.5	2.0	3.5		
		170	0.2	1.6	3.1		
Release point	B_{RP}	-40	-3.7	-2.2	-0.6	mT	
		25	-3.5	-2.0	-0.5		
		170	-3.1	-1.6	-0.2		
Hysteresis	B_{HYS}	-40	2.8	4.4	5.7	mT	
		25	2.6	4.0	5.4		
		170	2.2	3.1	4.7		
Effective noise value of the magnetic switching points ¹⁾²⁾	B_{Neff}	25		39		μT	
Temperature compensation of magnetic thresholds ²⁾	T_C			-1500		ppm/ K	

- 1) The magnetic noise is normal distributed and can be assumed as nearly independent to frequency without sampling noise or digital noise effects. The typical value represents the rms-value and corresponds therefore to a 1σ probability of normal distribution. Consequently a 3σ value corresponds to 0.3% probability of appearance.
- 2) Not subject to production test, verified by design/characterization.

Field Direction Definition

Positive magnetic fields are defined with the south pole of the magnet to the branded side of package.

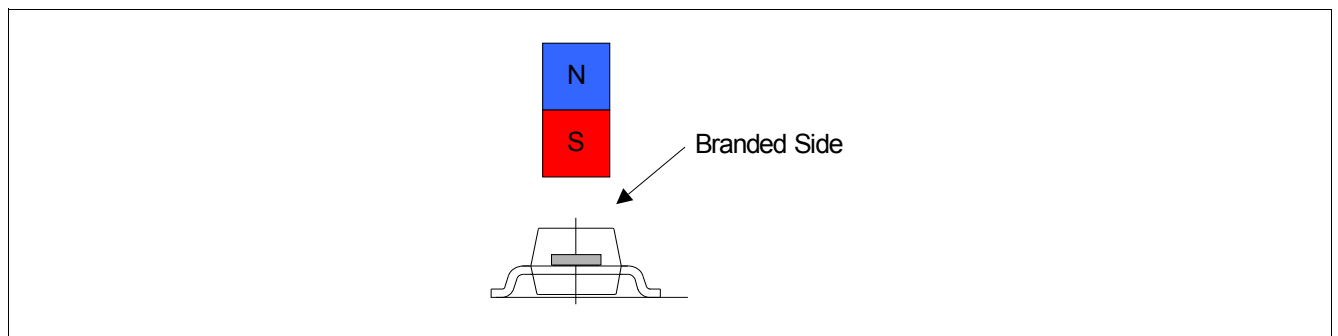

Figure 8 Definition of Magnetic Field Direction PG-SOT23-3-15

Package Information

4 Package Information

The TLE4963-1M is available in the small halogen free SMD package PG-SOT23-3-15.

4.1 Package Outline PG-SOT23-3-15

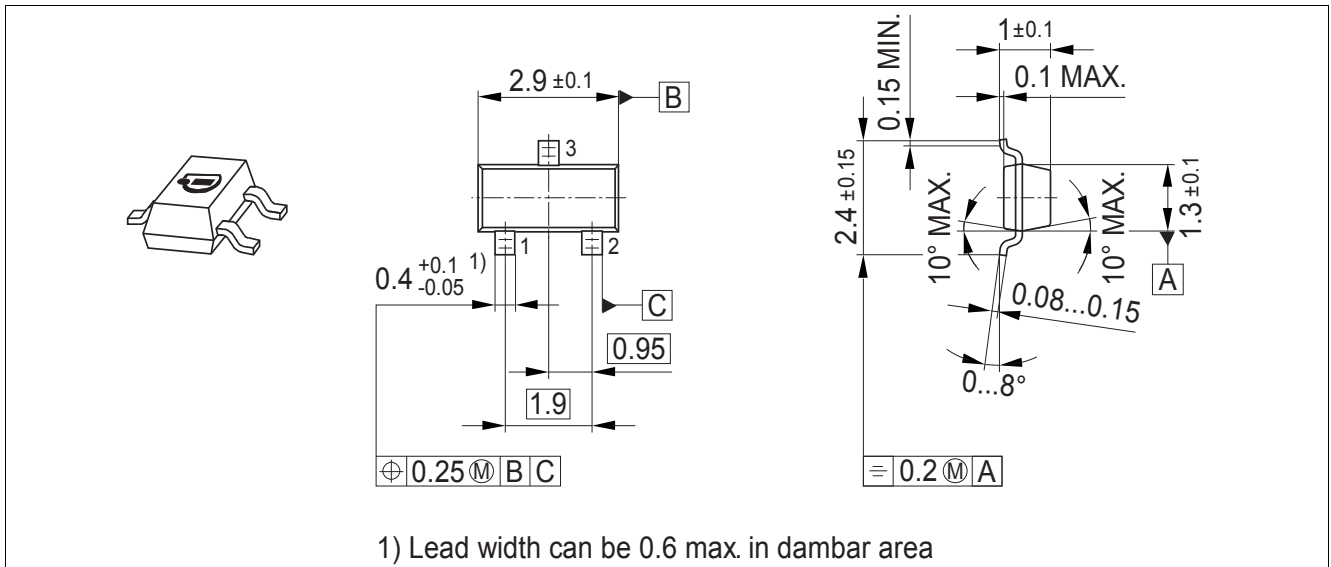

Figure 9 PG-SOT23-3-15 Package Outline (All Dimensions in mm)

4.2 Footprint PG-SC59-3-5 and PG-SOT23-3-15

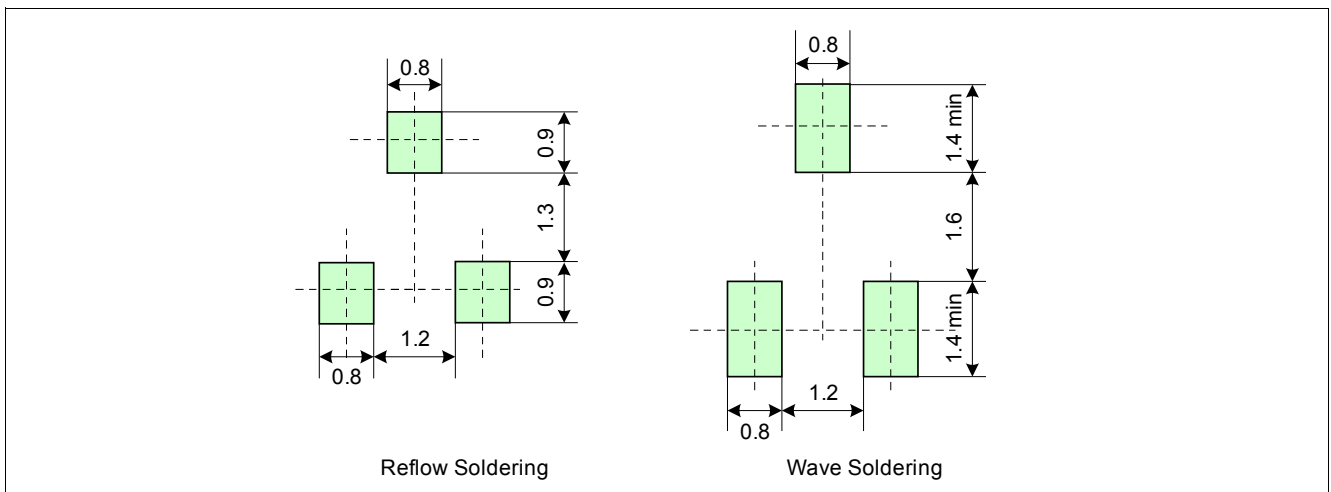

Figure 10 Footprint PG-SC59-3-5 and PG-SOT23-3-15

Package Information

4.3 Packing Information PG-SOT23-3-15

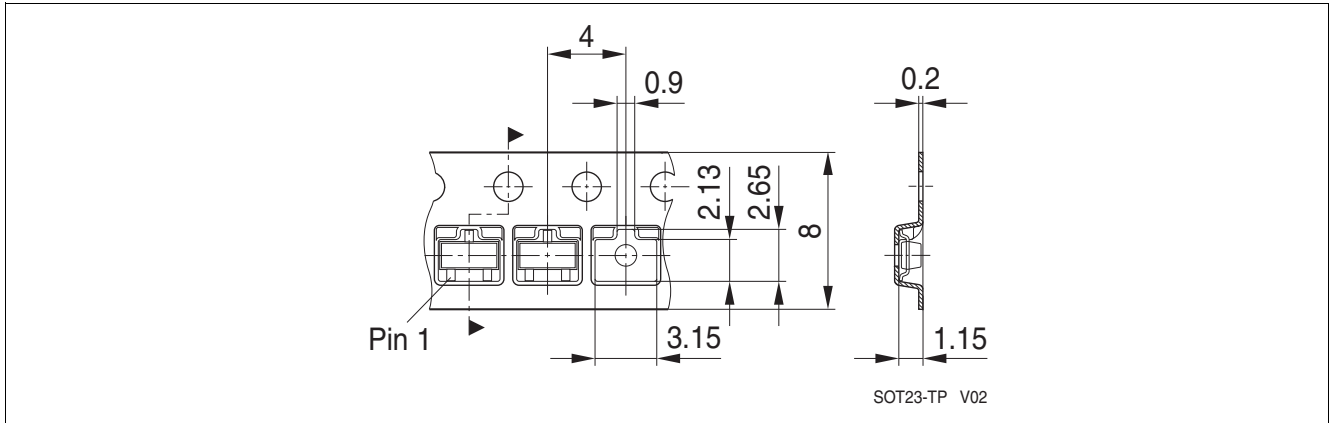

Figure 11 Packing of the PG-SOT23-3-15 in a Tape

4.4 PG-SOT23-3-15 Distance between Chip and Package

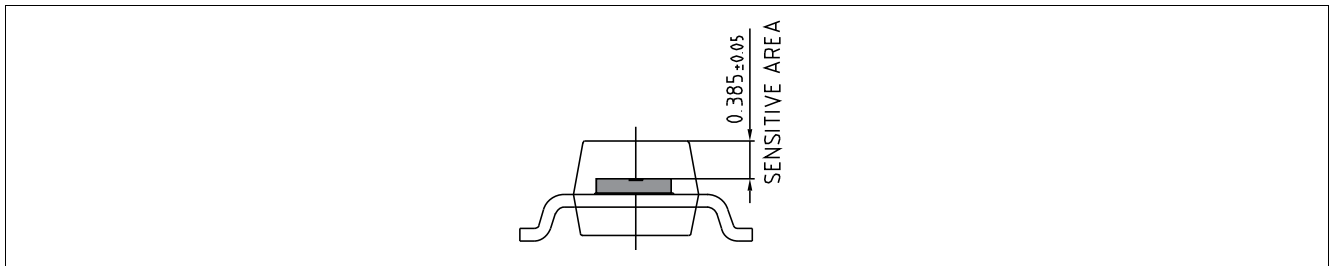

Figure 12 Distance between Chip and Package

4.5 Package Marking

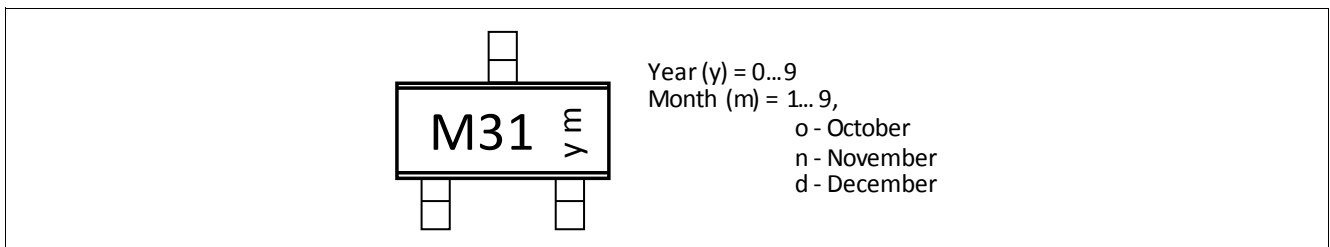

Figure 13 Marking of TLE4963-1M

Revision History

5 Revision History

Revision	Date	Changes
1.0	2016-01-12	Initial release

Trademarks of Infineon Technologies AG

AURIX™, C166™, CanPAK™, CIPOS™, CIPURSE™, CoolMOS™, CoolSET™, CORECONTROL™, CROSSAVE™, DAVE™, DI-POL™, EasyPIM™, EconoBRIDGE™, EconoDUAL™, EconoPIM™, EconoPACK™, EiceDRIVER™, eupec™, FCOS™, HITFET™, HybridPACK™, I²RF™, ISOFACE™, IsoPACK™, LITIX™, MIPAQ™, ModSTACK™, my-d™, NovalithIC™, OptiMOS™, ORIGA™, POWERCODE™, PRIMARION™, PrimePACK™, PrimeSTACK™, PRO-SIL™, PROFET™, RASIC™, ReverSave™, SatRIC™, SIEGET™, SINDRION™, SIPMOS™, SmartLEWIS™, SPOC™, SOLID FLASH™, TEMPFET™, thinQ!™, TRENCHSTOP™, TriCore™.

Other Trademarks

Advance Design System™ (ADS) of Agilent Technologies, AMBA™, ARM™, MULTI-ICE™, KEIL™, PRIMECELL™, REALVIEW™, THUMB™, μVision™ of ARM Limited, UK. AUTOSAR™ is licensed by AUTOSAR development partnership. Bluetooth™ of Bluetooth SIG Inc. CAT-iq™ of DECT Forum. COLOSSUS™, FirstGPS™ of Trimble Navigation Ltd. EMV™ of EMVCo, LLC (Visa Holdings Inc.). EPCOS™ of Epcos AG. FLEXGO™ of Microsoft Corporation. FlexRay™ is licensed by FlexRay Consortium. HYPERTERMINAL™ of Hilgraeve Incorporated. IEC™ of Commission Electrotechnique Internationale. IrDA™ of Infrared Data Association Corporation. ISO™ of INTERNATIONAL ORGANIZATION FOR STANDARDIZATION. MATLAB™ of MathWorks, Inc. MAXIM™ of Maxim Integrated Products, Inc. MICROTEC™, NUCLEUS™ of Mentor Graphics Corporation. MIPI™ of MIPI Alliance, Inc. MIPS™ of MIPS Technologies, Inc., USA. muRata™ of MURATA MANUFACTURING CO., MICROWAVE OFFICE™ (MWO) of Applied Wave Research Inc., OmniVision™ of OmniVision Technologies, Inc. Openwave™ Openwave Systems Inc. RED HAT™ Red Hat, Inc. RFMD™ RF Micro Devices, Inc. SIRIUS™ of Sirius Satellite Radio Inc. SOLARIS™ of Sun Microsystems, Inc. SPANSION™ of Spansion LLC Ltd. Symbian™ of Symbian Software Limited. TAIYO YUDEN™ of Taiyo Yuden Co. TEAKLITE™ of CEVA, Inc. TEKTRONIX™ of Tektronix Inc. TOKO™ of TOKO KABUSHIKI KAISHA TA. UNIX™ of X/Open Company Limited. VERILOG™, PALLADIUM™ of Cadence Design Systems, Inc. VLYNQ™ of Texas Instruments Incorporated. VXWORKS™, WIND RIVER™ of WIND RIVER SYSTEMS, INC. ZETEX™ of Diodes Zetex Limited.

Last Trademarks Update 2011-11-11

www.infineon.com

Edition 2016-01-12

Published by

Infineon Technologies AG

81726 Munich, Germany

© 2014 Infineon Technologies AG.

All Rights Reserved.

Do you have a question about any aspect of this document?

Email: erratum@infineon.com

Document reference

Legal Disclaimer

The information given in this document shall in no event be regarded as a guarantee of conditions or characteristics. With respect to any examples or hints given herein, any typical values stated herein and/or any information regarding the application of the device, Infineon Technologies hereby disclaims any and all warranties and liabilities of any kind, including without limitation, warranties of non-infringement of intellectual property rights of any third party.

Information

For further information on technology, delivery terms and conditions and prices, please contact the nearest Infineon Technologies Office (www.infineon.com).

Warnings

Due to technical requirements, components may contain dangerous substances. For information on the types in question, please contact the nearest Infineon Technologies Office. Infineon Technologies components may be used in life-support devices or systems only with the express written approval of Infineon Technologies, if a failure of such components can reasonably be expected to cause the failure of that life-support device or system or to affect the safety or effectiveness of that device or system. Life support devices or systems are intended to be implanted in the human body or to support and/or maintain and sustain and/or protect human life. If they fail, it is reasonable to assume that the health of the user or other persons may be endangered.