



Chipsmall Limited consists of a professional team with an average of over 10 year of expertise in the distribution of electronic components. Based in Hongkong, we have already established firm and mutual-benefit business relationships with customers from,Europe,America and south Asia,supplying obsolete and hard-to-find components to meet their specific needs.

With the principle of “Quality Parts,Customers Priority,Honest Operation,and Considerate Service”,our business mainly focus on the distribution of electronic components. Line cards we deal with include Microchip,ALPS,ROHM,Xilinx,Pulse,ON,Everlight and Freescale. Main products comprise IC,Modules,Potentiometer,IC Socket,Relay,Connector.Our parts cover such applications as commercial,industrial, and automotives areas.

We are looking forward to setting up business relationship with you and hope to provide you with the best service and solution. Let us make a better world for our industry!



Contact us

Tel: +86-755-8981 8866 Fax: +86-755-8427 6832

Email & Skype: info@chipsmall.com Web: www.chipsmall.com

Address: A1208, Overseas Decoration Building, #122 Zhenhua RD., Futian, Shenzhen, China





Smart Quad Channel Low-Side Switch

Features

Product Summary

- Shorted Circuit Protection
- Overtemperature Protection
- Overvoltage Protection
- Parallel Control of the Inputs (PWM Applications)
- Separate Diagnostic Pin for Each Channel
- Power - SO 20 - Package with integrated cooling area
- Standby mode with low current consumption
- μ C compatible Input
- **E**lectrostatic **D**ischarge (ESD) Protection
- Green Product (RoHS compliant)
- AEC qualified

| | | |
|----------------------|-----------------|---------------|
| Supply voltage | V_S | 4.8 - 32 V |
| Drain source voltage | $V_{DS(AZ)max}$ | 60 V |
| On resistance | $R_{ON 1,2}$ | 0.23 Ω |
| | $R_{ON 3,4}$ | 0.28 Ω |
| Output current | $I_D 1,2 (max)$ | 2 x 5 A |
| | $I_D 3,4 (max)$ | 2 x 3 A |



Application

- All kinds of resistive and inductive loads (relays,electromagnetic valves)
- μ C compatible power switch for 12 and 24 V applications
- Solenoid control switch in automotive and industrial control systems
- Robotic Controls

General description

Quad channel Low-Side-Switch (2x5A/2x3A) in Smart Power Technology (SPT) with four separate inputs and four open drain DMOS output stages. The TLE 6228 GP is fully protected by embedded protection functions and designed for automotive and industrial applications. Each channel has its own status signal for diagnostic feedback. Therefore the TLE 6228 GP is particularly suitable for ABS or Powertrain Systems.

Block Diagram

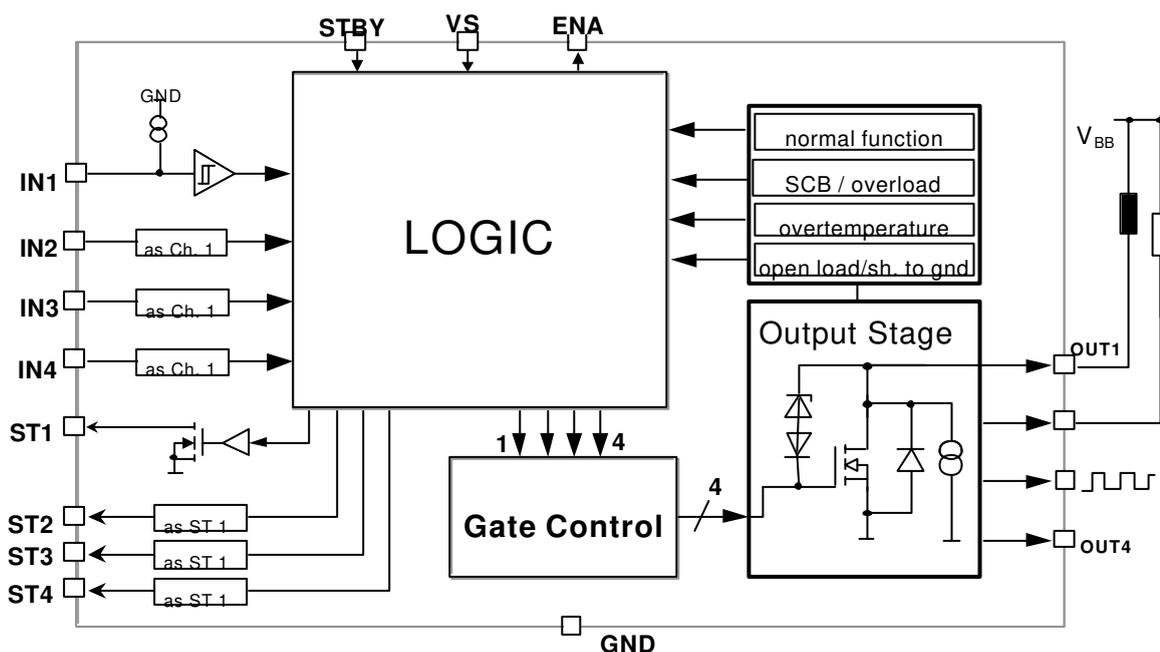

Detailed Block Diagram

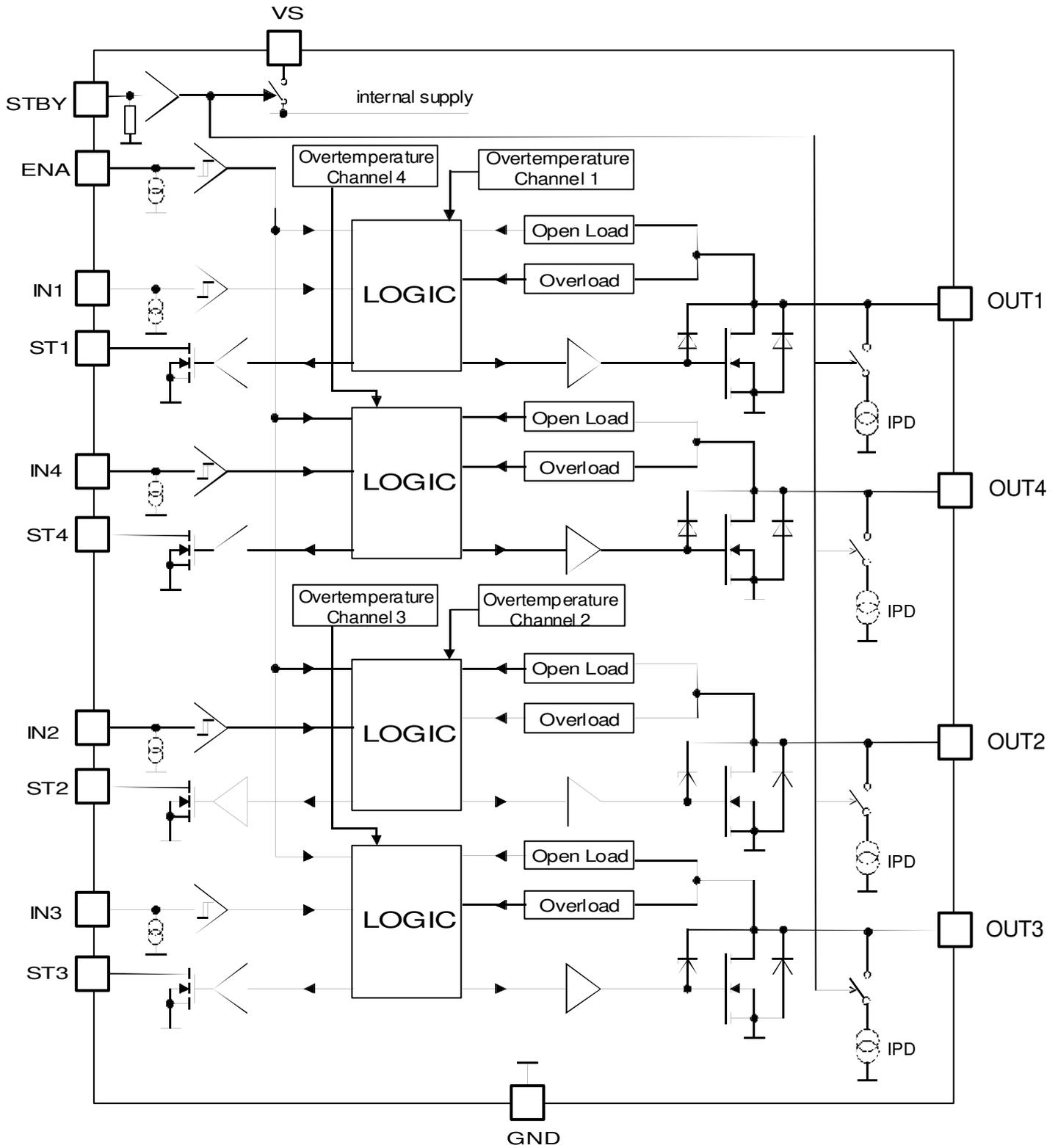

Pin Description

| Pin | Symbol | Function |
|-----|--------|------------------------------------|
| 1 | GND | Ground |
| 2 | OUT1 | Power Output channel 1 |
| 3 | ST1 | Status Output channel 1 |
| 4 | IN4 | Control Input channel 4 |
| 5 | VS | Supply Voltage |
| 6 | STBY | Standby |
| 7 | IN3 | Control Input channel 3 |
| 8 | ST2 | Status Output channel 2 |
| 9 | OUT2 | Power Output channel 2 |
| 10 | GND | Ground |
| 11 | GND | Ground |
| 12 | OUT3 | Power Output channel 3 |
| 13 | ST3 | Status Output channel 3 |
| 14 | IN2 | Control Input channel 2 |
| 15 | GND | Ground Logic |
| 16 | ENA | Enable Input for all four channels |
| 17 | IN1 | Control Input channel 1 |
| 18 | ST4 | Status Output channel 4 |
| 19 | OUT4 | Power Output channel 4 |
| 20 | GND | Ground |

Pin Configuration (Top view)

| | | | |
|------|-----|----|------|
| GND | 1 ● | 20 | GND |
| OUT1 | 2 | 19 | OUT4 |
| ST1 | 3 | 18 | ST4 |
| IN4 | 4 | 17 | IN1 |
| VS | 5 | 16 | ENA |
| STBY | 6 | 15 | GNDL |
| IN3 | 7 | 14 | IN2 |
| ST2 | 8 | 13 | ST3 |
| OUT2 | 9 | 12 | OUT3 |
| GND | 10 | 11 | GND |

PG - DSO - 20 - 65

Heat slug internally connected to ground pins

Maximum Ratings for $T_j = -40^{\circ}\text{C}$ to 150°C

The maximum ratings may not be exceeded under any circumstances, not even momentarily and individually, as permanent damage to the IC will result.

| Parameter | Symbol | Values | Unit |
|---|----------------------|------------------|--------------------|
| Supply voltage | V_S | -0.3 ... + 40 | V |
| Continuous drain source voltage (OUT1...OUT4) | V_{DS} | 45 | V |
| Input voltage IN1 to IN4, ENA | V_{IN}, V_{ENA} | - 0.3 ... + 6 | V |
| Input voltage STBY | V_{STBY} | - 0.3 ... + 40 | |
| Status output voltage | V_{ST} | - 0.3 ... + 32 | V |
| Load Dump Protection $V_{Load Dump} = U_P + U_S$; $U_P = 13.5\text{ V}$ $R_l^{1)} = 2\ \Omega$; $t_D = 400\text{ms}$; IN = low or high With $R_L = 5\ \Omega$ for Ch. 1,2; $10\ \Omega$ for Ch. 3,4 ($I_D = 2,7\text{A}$ respectively $1,35\text{A}$) | $V_{Load Dump}^{2)}$ | 55 | V |
| Operating temperature range | T_j | - 40 ... + 150 | $^{\circ}\text{C}$ |
| Storage temperature range | T_{stg} | - 55 ... + 150 | |
| Output current per channel (see page 6) | $I_{D(lim)}$ | $I_{D(lim) min}$ | A |
| Status output current | I_{ST} | - 5 ... + 5 | mA |
| Inductive load switch off energy (single pulse) $T_j = 25^{\circ}\text{C}$ | E_{AS} | 50 | mJ |
| Electrostatic Discharge Voltage (human body model) according to MIL STD 883D, method 3015.7 and EOS/ESD asn. standard S5.1 - 1993 | V_{ESD} | 2000 | V |
| DIN Humidity Category, DIN 40 040 | | E | |
| IEC Climatic Category, DIN IEC 68-1 | | 40/150/56 | |
| Thermal resistance | | | K/W |
| junction – case (die soldered on the frame) | R_{thJC} | 2 | |
| junction - ambient @ min. footprint | R_{thJA} | 50 | |
| junction - ambient @ 6 cm^2 cooling area | | 38 | |

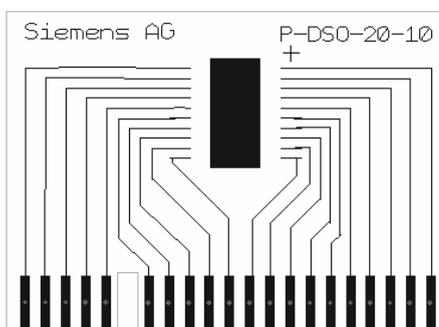

Minimum footprint

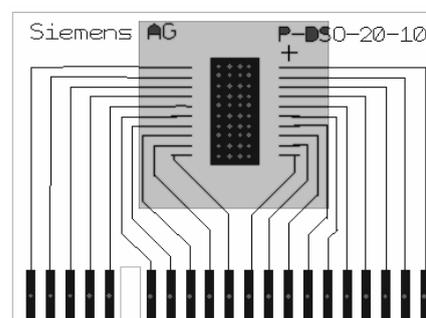

PCB with heat pipes,
backside 6 cm^2 cooling area

¹⁾ R_l = internal resistance of the load dump test pulse generator LD200

²⁾ $V_{LoadDump}$ is setup without DUT connected to the generator per ISO 7637-1 and DIN 40 839.

Electrical Characteristics

| Parameter and Conditions $V_S = 4.8$ to 18 V ; $T_j = -40$ °C to $+150$ °C (unless otherwise specified) | Symbol | Values | | | Unit |
|---|--------|--------|-----|-----|------|
| | | min | typ | max | |

1. Power Supply (V_S)

| | | | | | |
|---|-------|-----|--|----|---------|
| Supply current (Outputs ON) | I_S | | | 8 | mA |
| Supply current (Outputs OFF) $V_{ENA} = L, V_{STBY} = H$ | I_S | | | 4 | mA |
| Standby current $V_{STBY} = L$ | I_S | | | 10 | μ A |
| Operating voltage | V_S | 4.8 | | 32 | V |

2. Power Outputs

| | | | | | | |
|--|---------------------------------|-----------------|-----|--------------|-------------|----------|
| ON state resistance Channel 1,2 $I_D = 1$ A; $V_S \geq 9.5$ V | $T_j = 25$ °C $T_j = 150$ °C | $R_{DS(ON)}$ | | 0.23 0.26 | 0.26 0.5 | Ω |
| ON state resistance Channel 3,4 $I_D = 1$ A; $V_S \geq 9.5$ V | $T_j = 25$ °C $T_j = 150$ °C | $R_{DS(ON)}$ | | 0.28 0.75 | 0.4 0.75 | Ω |
| Z-Diode clamping voltage (OUT1...4) $I_D \geq 100$ mA | | $V_{DS(AZ)}$ | 45 | | 60 | V |
| Pull down current $V_{STBY} = H, V_{IN} = L$ | | I_{PD} | 10 | 20 | 50 | μ A |
| Output leakage current ³ $V_{STBY} = L, 0V \leq V_{DS} \leq 20V$ | | I_{DIK} | | | 5 | μ A |
| Output turn on time ⁴ $I_D = 1$ A | | t_{on} | 3 | 15 | 50 | μ s |
| Output turn off time ⁴ $I_D = 1$ A | | t_{off} | 3 | 20 | 60 | |
| Output on fall time ⁴ $I_D = 1$ A | | t_{fall} | 3 | 10 | 30 | |
| Output off rise time ⁴ $I_D = 1$ A | | t_{rise} | 3 | 5 | 30 | |
| Overload switch-off delay time ⁴ | | t_{DSO} | 20 | 60 | 100 | |
| Output off status delay time ⁴ | | t_D | 500 | 1200 | 3000 | |
| Failure extension Time for Status Report | | $t_{D-failure}$ | 500 | 1200 | 3000 | |
| Input Suppression Time | | t_{D-IN} | 500 | 1200 | 3000 | |
| Open Load (off) filtering Time ⁵ | | $t_{fOL(off)}$ | 10 | 30 | 100 | |

3. Digital Inputs (IN1, IN2, IN3, IN4, ENA)

| | | | | | |
|---|-------------|-------|-----|-----|---------|
| Input low voltage | V_{INL} | - 0.3 | | 1.0 | V |
| Input high voltage | V_{INH} | 2.0 | | 6.0 | V |
| Input voltage hysteresis ⁵ | V_{INHys} | 50 | 200 | | mV |
| Input pull down current $V_{IN} = 5$ V; $V_S \geq 6.5$ V | I_{IN} | 10 | 30 | 60 | μ A |
| Enable pull down current $V_{ENA} = 5$ V; $V_S \geq 6.5$ V | I_{ENA} | 10 | 20 | 40 | μ A |

4. Digital Status Outputs (ST1 - ST4) Open Drain

| | | | | | |
|---------------------------------------|-----------|--|--|-----|---------|
| Output voltage low $I_{ST} = 2$ mA | V_{STL} | | | 0.5 | V |
| Leakage current high | I_{STH} | | | 2 | μ A |

³ If the output voltage exceeds 35V, this current (zener current of a internal structure) can rise up to 1mA

⁴ See timing diagram, resistive load condition; $V_S \geq 9$ V

⁵ This parameter will not be testet but assured by design

Electrical Characteristics

| Parameter and Conditions $V_S = 4.8$ to 18 V ; $T_j = -40$ °C to $+150$ °C (unless otherwise specified) | Symbol | Values | | | Unit |
|---|--------|--------|-----|-----|------|
| | | min | typ | max | |

5. Standby Input (STBY)

| | | | | | |
|---------------------------------|------------|-----|--|-------|---------|
| Input low voltage | V_{STBY} | 0 | | 1 | V |
| Input high voltage | V_{STBY} | 3.5 | | V_S | V |
| Input current $V_{STBY} = 18$ V | I_{STBY} | | | 300 | μ A |

6. Diagnostic Functions

| | | | | | | |
|---|------------------|-----------------------|-----------------|------------------|------------------|---------|
| Open load detection voltage $V_{ENA} = X, V_{IN} = L$ | $V_S \geq 6.5$ V | $V_{D(SOL)}$ | $0.3 \cdot V_S$ | $0.33 \cdot V_S$ | $0.36 \cdot V_S$ | V |
| Open load detection current channel 1,2 $V_{ENA} = V_{IN} = H$ | $V_S \geq 6.5$ V | $I_{D(OL) 1,2}$ | 100 | 160 | 250 | mA |
| Open load detection current channel 3,4 $V_{ENA} = V_{IN} = H$ | $V_S \geq 6.5$ V | $I_{D(OL) 3,4}$ | 100 | 160 | 250 | mA |
| Overload detection current channel 1,2 | $V_S \geq 6.5$ V | $I_{D(lim) 1,2}$ | 5 | 7.5 | | A |
| Overload detection current channel 3,4 | $V_S \geq 6.5$ V | $I_{D(lim) 3,4}$ | 3 | 5.5 | | A |
| Overtemperature shutdown threshold ⁵ Hysteresis | | T_{th} T_{hys} | 170 | 10 | 200 | °C K |
| Pulse Width for static diagnostic output | | t_{IN} | | | 500 | μ s |

⁵ This parameter will not be tested but assured by design

Application Description

This IC is especially designed to drive inductive loads (relays, electromagnetic valves). Integrated clamp-diodes limit the output voltage when inductive loads are discharged.

Four open-drain logic outputs indicate the status of the integrated circuit. The following conditions are monitored and signalled:

- overloading of output (also shorted load to supply) in active mode
- open and shorted load to ground in active and inactive mode
- overtemperature

Circuit Description

Input Circuits

The control and enable inputs, both active high, consist of schmitt triggers with hysteresis. All inputs are provided with pull-down current sources. Not connected inputs are interpreted as low and the respective output stages are switched off.

In standby mode (STBY = LOW) the current consumption is greatly reduced.

The circuit is active when STBY = HIGH.

If the standby function is not used, it is allowed to connect the standby pin directly to VS.

Status Signals: The status signals are undefined for 2ms after a power up event or a STBY low to high transition.

Output Stages

The four power outputs consist of DMOS-power transistors with open drains. The output stages are short circuit protected throughout the operating range. Each output has its own zenerclamp. This causes a voltage limitation at the power transistor when inductive loads are switched off.

Parallel to the DMOS transistors there are internal pull down current sources. They are provided to detect an open load condition in the off state. They will be disconnected in the standby mode.

Due to EMI measures there is an internal zenerclamp in parallel to the output stage. It gets active above 33V drain source voltage. This leads to an increasing leakage current up to 1 mA @ $V_{DS} = 40V$.

Protective Circuits

The outputs are protected⁶⁾ against current overload and overtemperature. If the output current increases above the overload detection threshold I_{BO} for a longer time than t_{DSO} or the temperature increases above T_{th} , then the power transistor is immediately switched off. It remains off until the control signal at the input is switched off and on again.

Fault Detection

The status outputs indicate the switching state of the output stage. Under normal conditions is: ST = low \Rightarrow Output off; ST = high \Rightarrow Output on. If an error occurs, the logic level of the status output is inverted, as listed in the diagnostic table.

⁶⁾ The integrated protection functions prevent an IC destruction under fault conditions and may not be used in normal operation or permanently.

If current overload or overtemperature occurs for a longer time than t_{DSO} , the fault condition is latched into an internal register and the output is shutdown. The reset is done by switching off the corresponding control input for a time longer than t_{D-IN} .

Open load is detected for all four channels in on and off mode.

In the on mode the load current is monitored. If it drops below the specified threshold value I_{QU} then an open load condition is detected.

In the off mode, the output voltage is monitored. An open load condition is detected when the output voltage of a given channel is below the threshold $V_{DS(OL)}$, which is typ. 33 % of the supply voltage V_S . To prevent an open load diagnosis in case of transient Voltages on the outputs the open load detection in off mode uses a filter of typ. 50 μ s.

Status output at pulse width operation

If the input is operated with a pulsed signal, the status does not follow each single pulse of the input signal. An internal delay t_D of typ. 1.2ms (min 500 μ s) enables a continuous status output signal. See the timing diagrams on the following pages for further information.

This internal status delay simplifies diagnostic software for pwm applications.

Diagnostic Table

In general the status follows the input signal in normal operating conditions.

If any error is detected the status is inverted.

| Operating Condition | Standby Input | Enable Input | Control Input | Power Output | Status Output |
|--|---------------|--------------|-------------------|--------------|---------------|
| | STBY | ENA | IN | Q | ST |
| Standby ¹⁾ | L | X | X | off | H |
| Normal function | H | L | X | off | L |
| | H | H | L | off | L |
| | H | H | H | ON | H |
| Open load or short to ground | H | L | L | off | H |
| | H | L | H | off | H |
| | H | H | L | off | H |
| | H | H | H | ON | L |
| Overload or short to supply ²⁾ reset latch ³⁾ | H | H | H | off | L |
| | H | H | H \rightarrow L | off | L |
| | H | L | X | off | L |
| Overtemperature ²⁾ reset latch ³⁾ | H | H | H | off | L |
| | H | H | H \rightarrow L | off | L |
| | H | L | X | off | L |

Note 1) : Standby is not designed for switching or PWM operation of the outputs

Note 2) : overload/short-to-supply/overtemperature - events shorter than min. time t_{DSO} specified in 2.10 will not be latched and not reported at the status pin.

Note 3) : to reset latched status-output in case of overload/short-to-supply/overtemperature the control input has to go low and stay low for longer than max. input suppression time t_{D-IN} specified in 2.13 of the characteristics

Failure Situations and Status Report

Logic Block Diagram

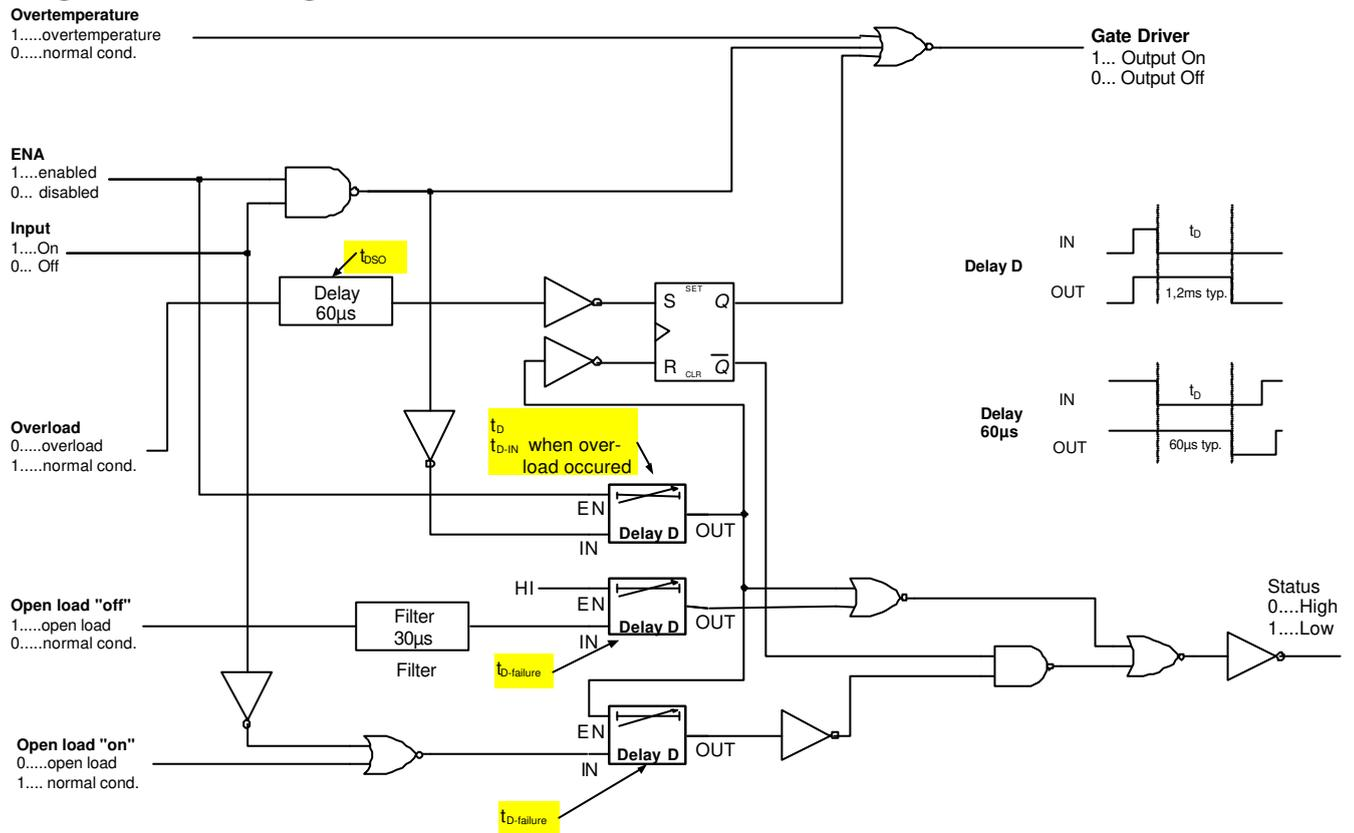

Timing Diagrams

Output Slope

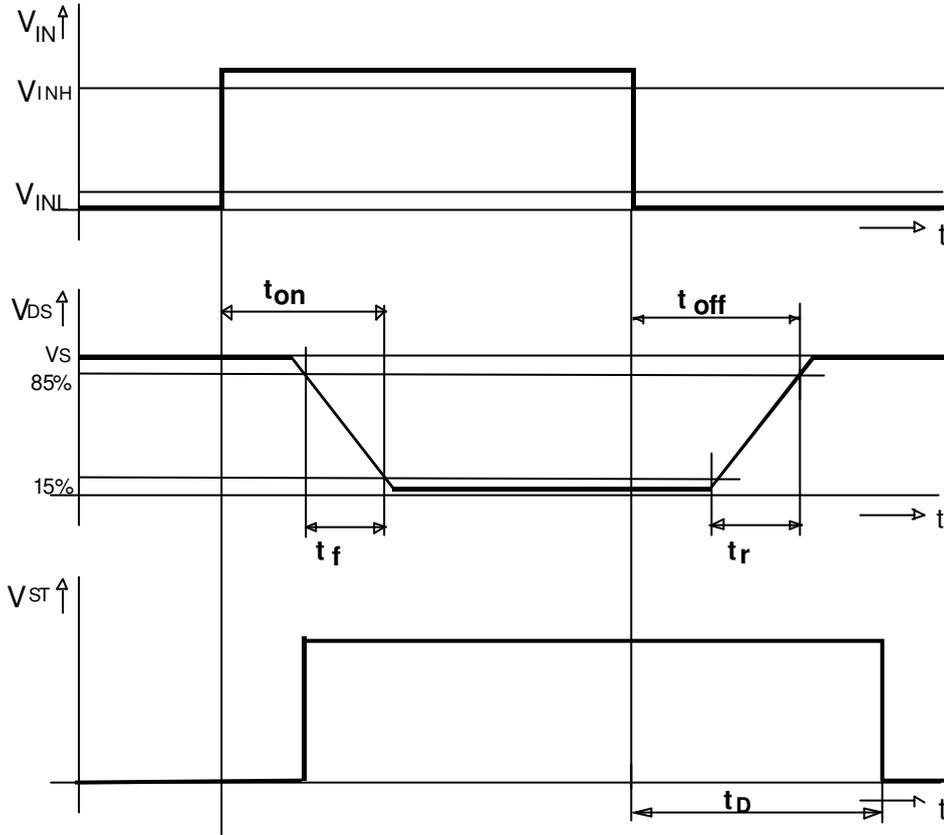

Fig. 1

Overload Switch OFF Delay

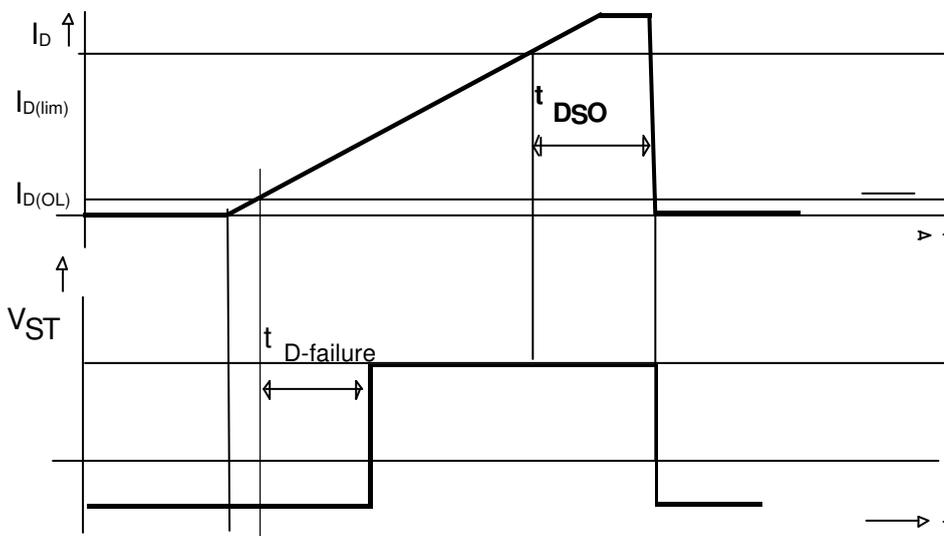
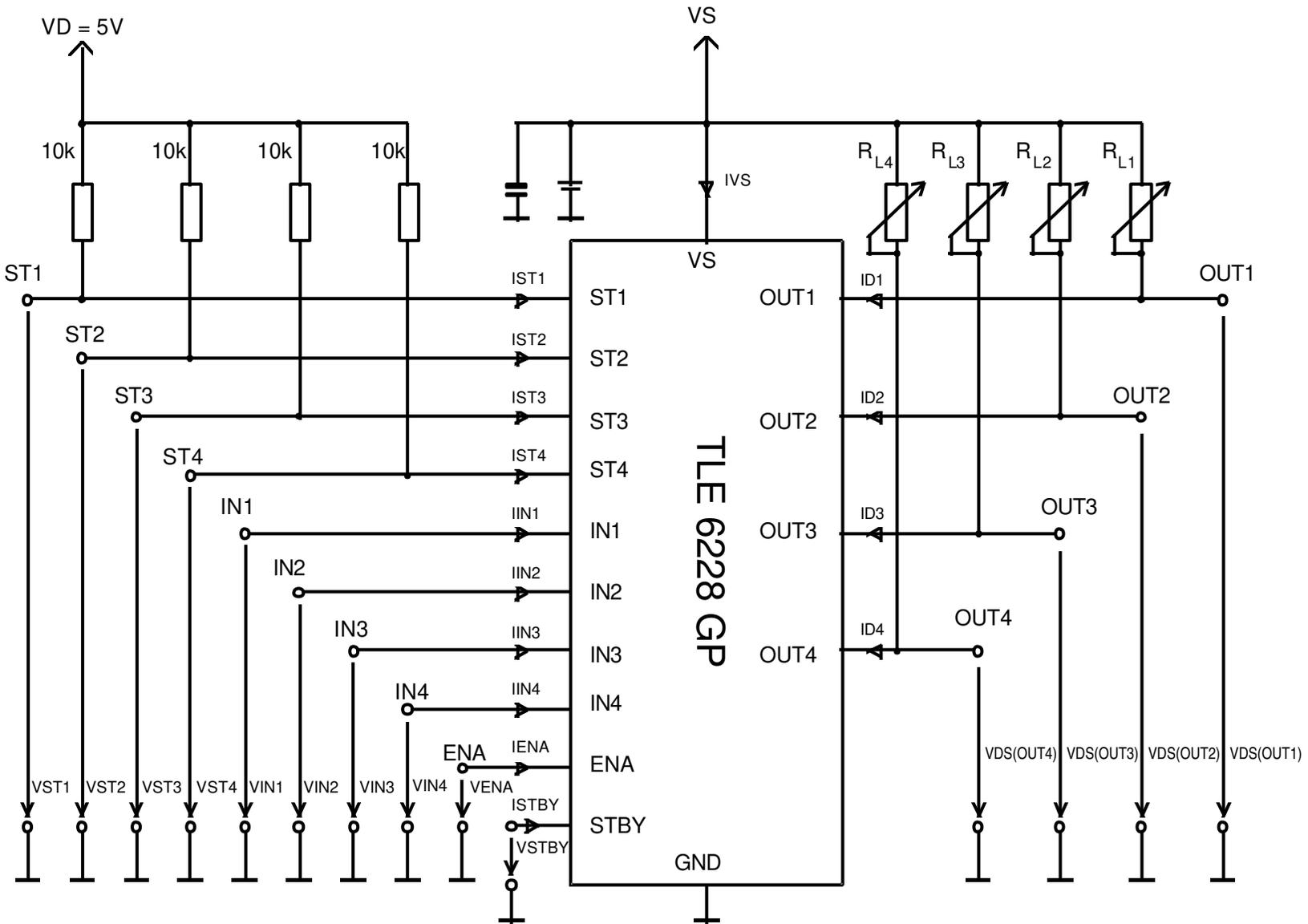
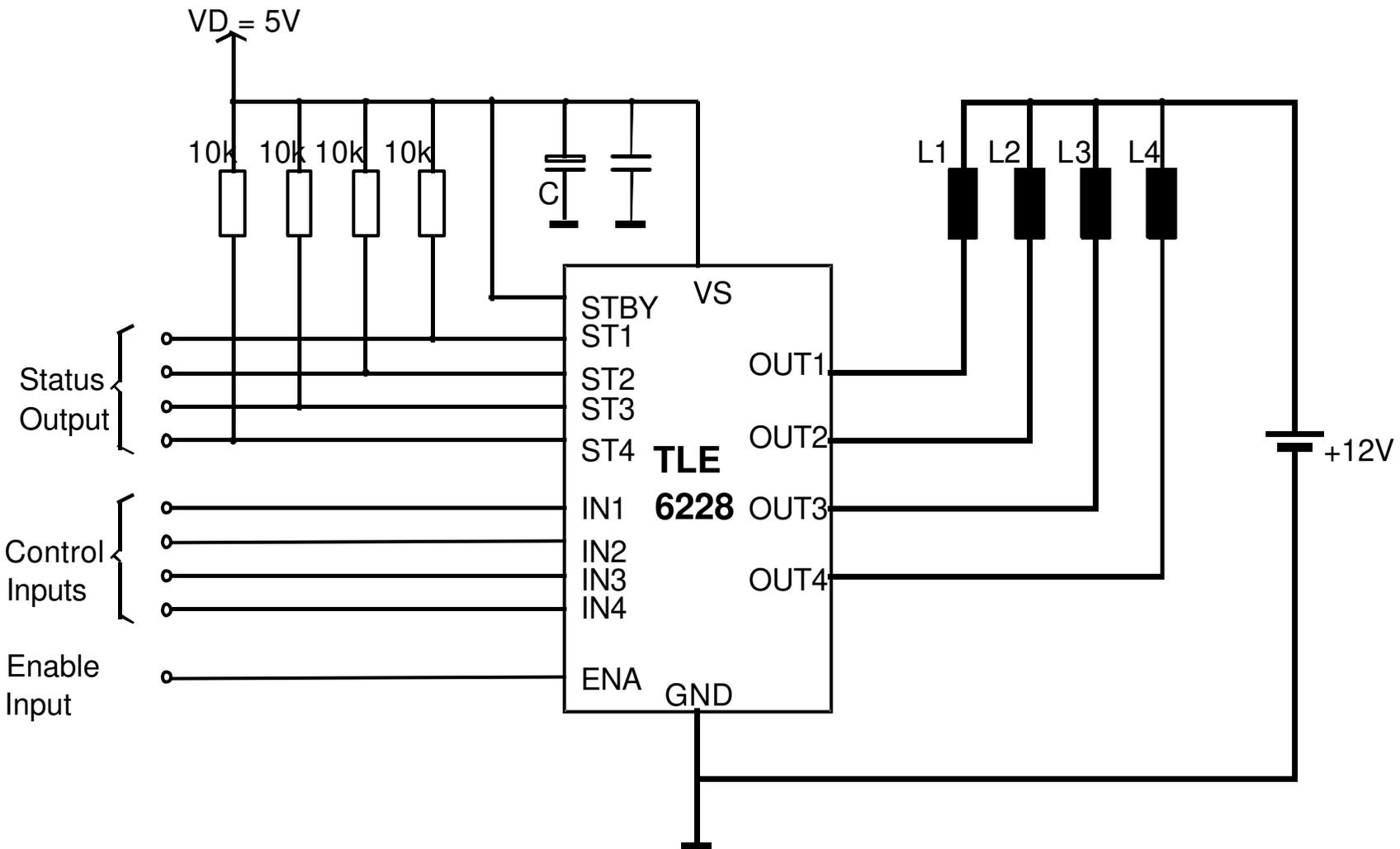

Fig. 2

Test Circuit



Application Circuit



The blocking capacitor C is recommended to avoid critical negative voltage spikes on VS in case of battery interruption during OFF-commutation.

Timing Diagrams of Diagnostic with Pulsed Input Signal

Normal condition, resistive load, pulsed input signal

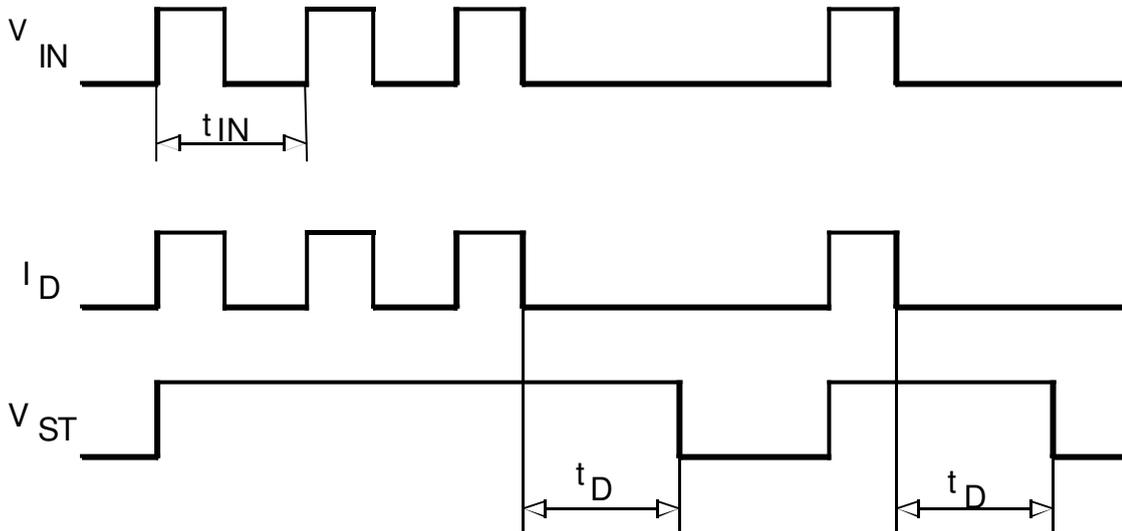
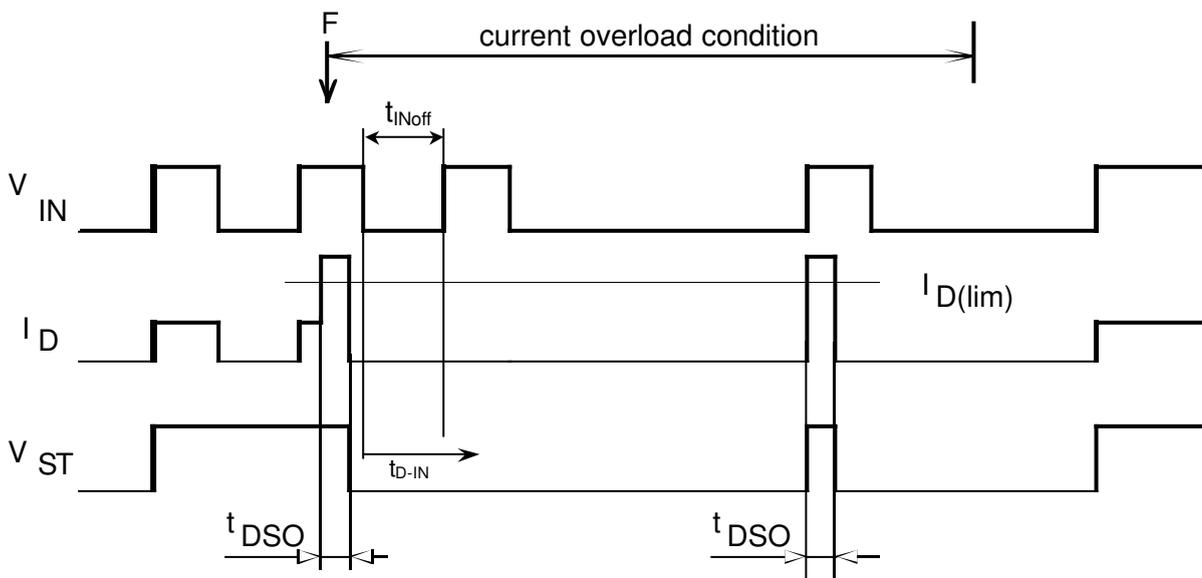

Fig. 3

Current Overload



$t_{INoff} < t_{D-IN}$: Input suppression time avoids a restart after overtemperature

Fig. 4

Diagnostic status output at different open load current conditions

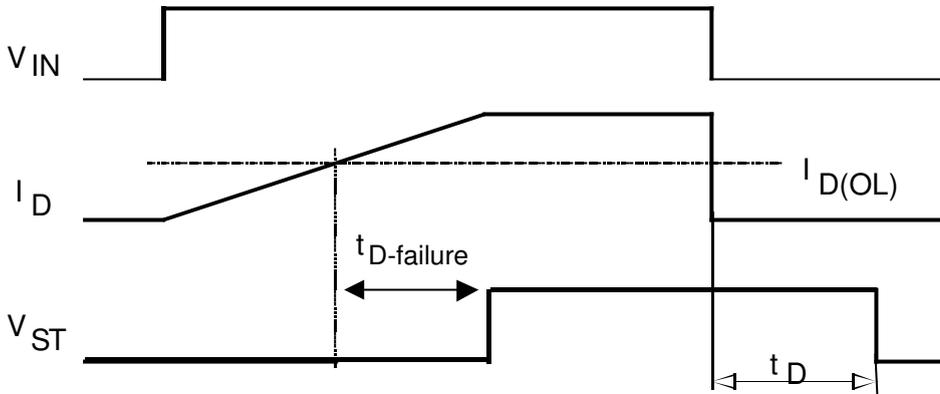
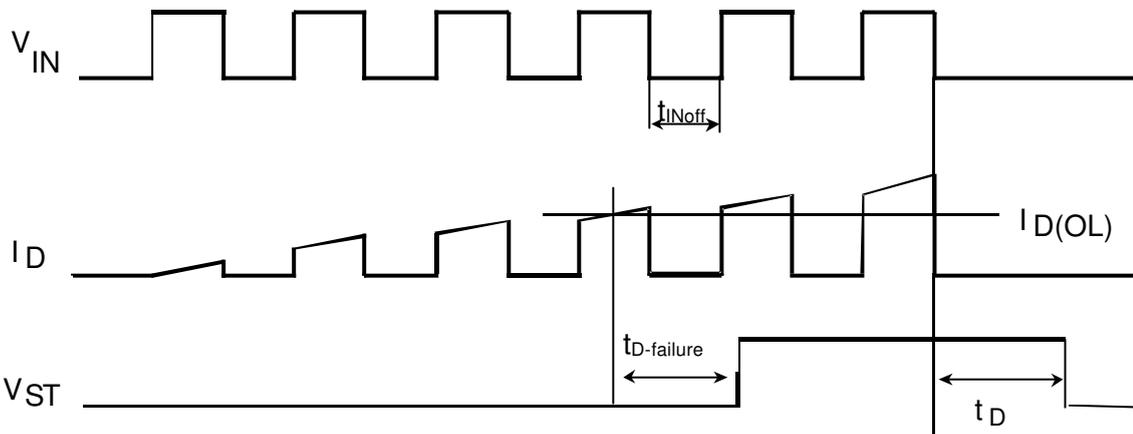
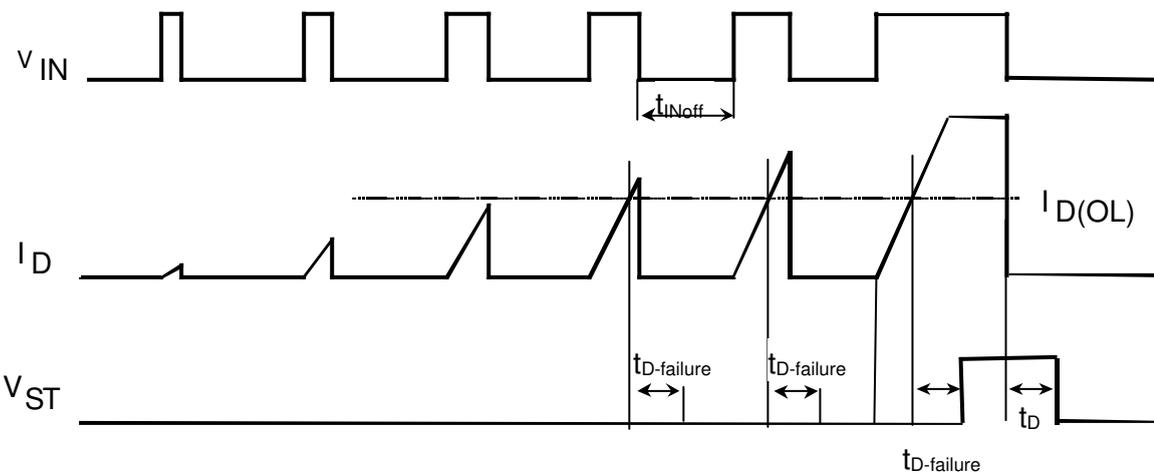

Fig. 5



$t_{INOFF} < t_D$ leads to a static status signal

Fig. 6



$t_{INOFF} > t_D$: Intermittent status signal

Fig. 7

Normal operation, followed by open load condition

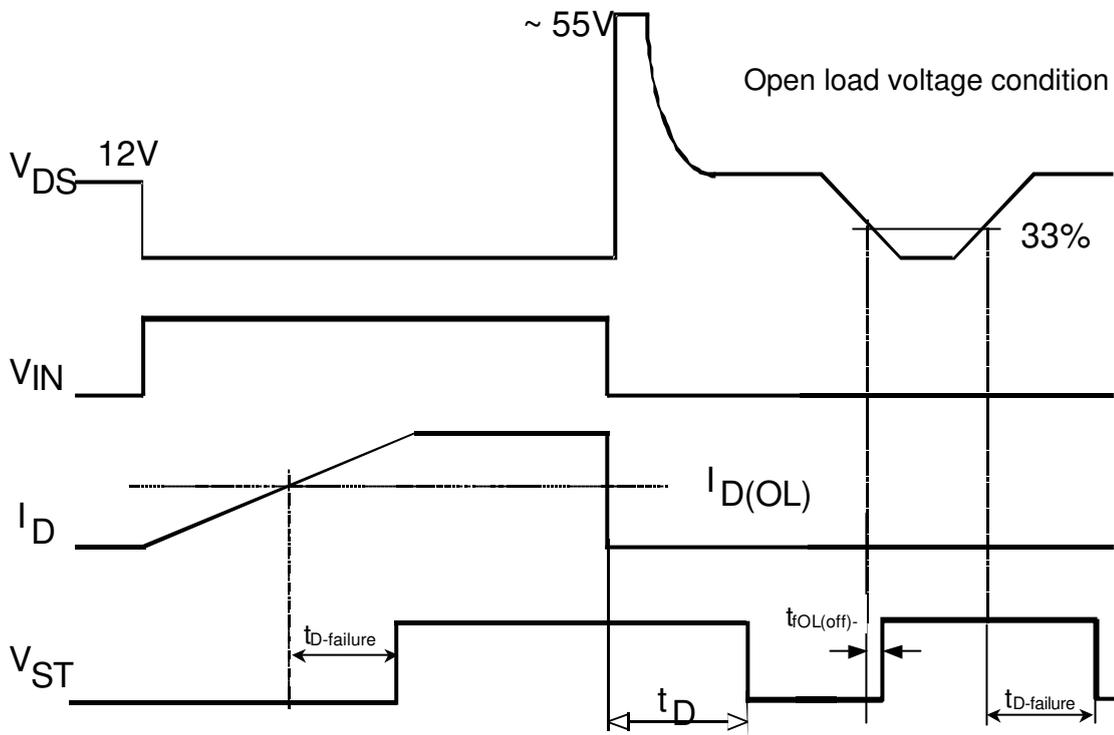

Fig. 8

Overtemperature

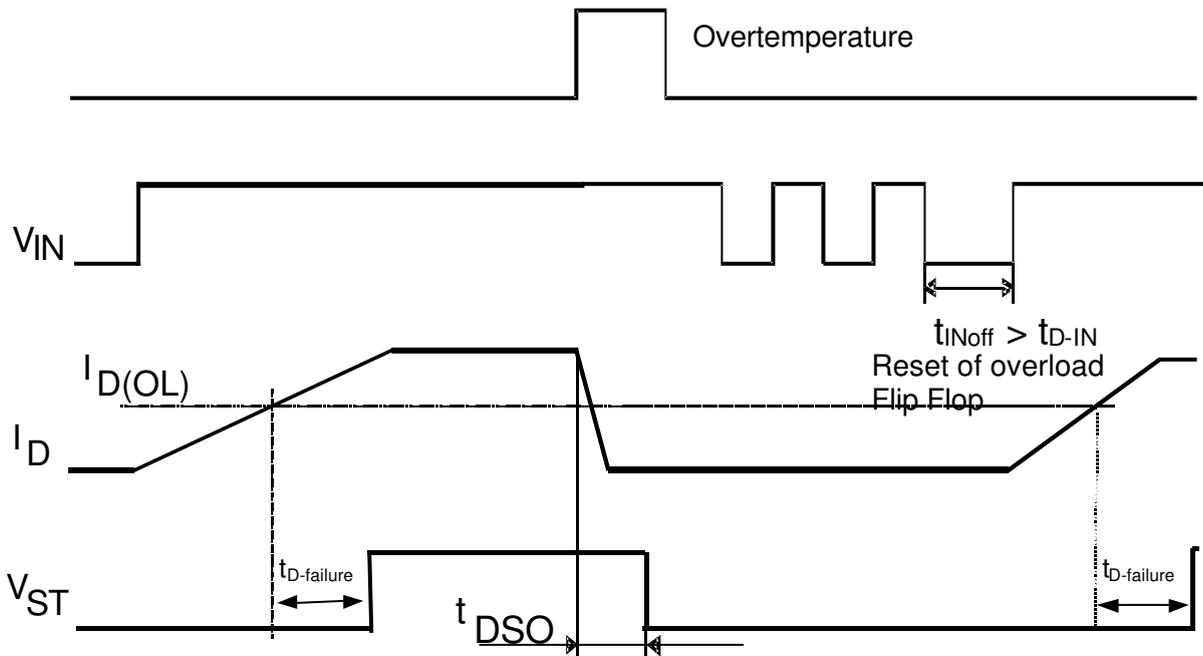

Fig. 9

Typical electrical Characteristics

Drain-Source on-resistance

$$R_{DS(ON)} = f(T_j) ; V_s = 9,5V$$

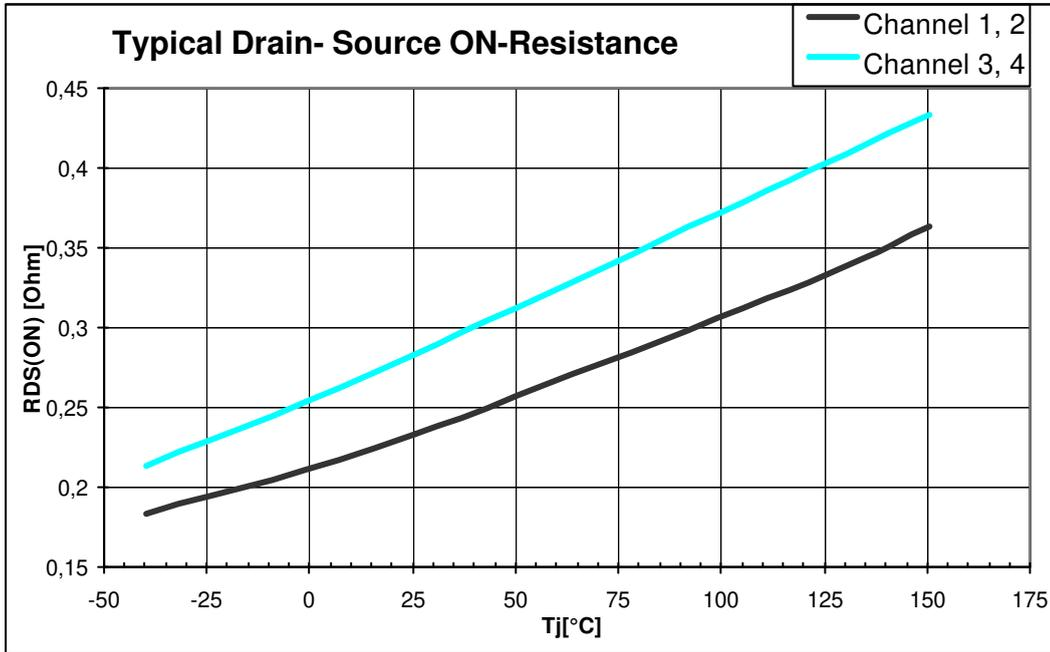

Figure 6 : Typical ON Resistance versus Junction-Temperature Channel 1-4

Output Clamping Voltage

$$V_{DS(AZ)} = f(T_j) ; I_D = 100mA$$

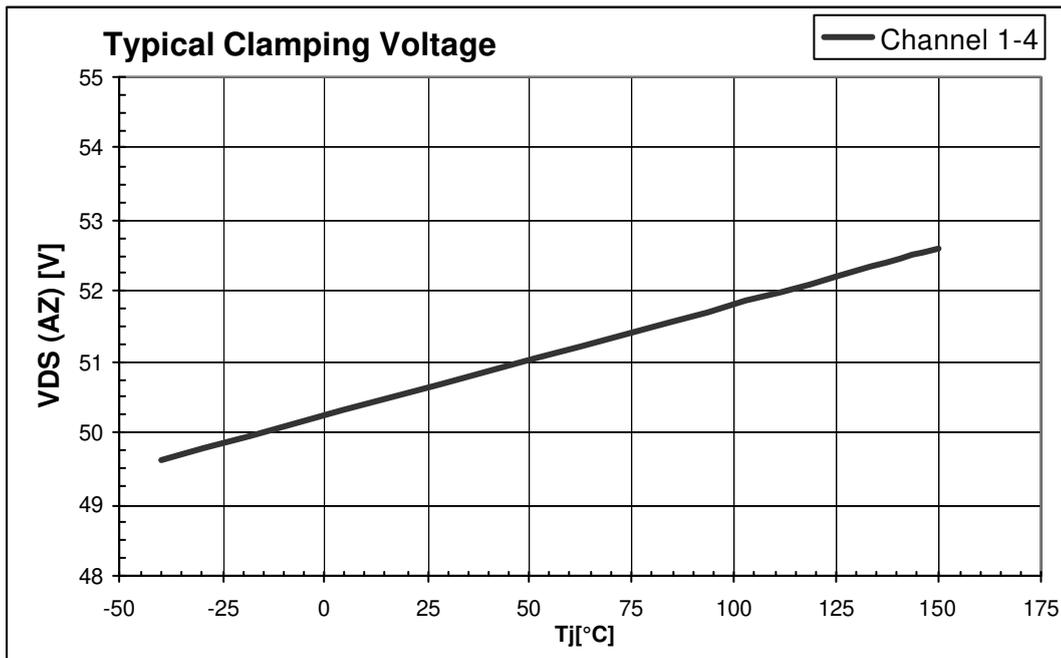

Figure 7 : Typical Clamp Voltage versus Junction-Temperature Channel 1-4

Revision History

| Version | Date | Changes |
|--|------------|---|
| V3.2 → V4.0: 2007-06-06: Version Change to Green Product | | |
| V4.0 | 2007-06-06 | Revision history implemented |
| V4.0 | 2007-06-06 | IFX Logo updated |
| V4.0 | 2007-06-06 | Package name according green nomenclature changed from P-DSO-20-12 to PG-DSO-20-37 |
| V4.0 | 2007-06-06 | Ordering Code removed |
| V4.0 | 2007-06-06 | Package Picture in front page up-dated |
| V4.0 | 2007-06-06 | Added in feature list: <ul style="list-style-type: none">• Green Product (RoHS compliant)• AEC qualified |
| V4.0 | 2007-06-11 | Green and AEC logo added |
| V4.0 | 2007-06-11 | Disclaimer re-newed |
| V4.1 | 2010-07-10 | Due to Cu wire bonding, package name changed from PG-DSO-20-37 to PG-DSO-20-65 |

Edition 2010-07-10

**Published by
Infineon Technologies AG
81726 Munich, Germany**

**© 2010 Infineon Technologies AG
All Rights Reserved.**

Legal Disclaimer

The information given in this document shall in no event be regarded as a guarantee of conditions or characteristics. With respect to any examples or hints given herein, any typical values stated herein and/or any information regarding the application of the device, Infineon Technologies hereby disclaims any and all warranties and liabilities of any kind, including without limitation, warranties of non-infringement of intellectual property rights of any third party.

Information

For further information on technology, delivery terms and conditions and prices, please contact the nearest Infineon Technologies Office (www.infineon.com).

Warnings

Due to technical requirements, components may contain dangerous substances. For information on the types in question, please contact the nearest Infineon Technologies Office.

Infineon Technologies components may be used in life-support devices or systems only with the express written approval of Infineon Technologies, if a failure of such components can reasonably be expected to cause the failure of that life-support device or system or to affect the safety or effectiveness of that device or system. Life support devices or systems are intended to be implanted in the human body or to support and/or maintain and sustain and/or protect human life. If they fail, it is reasonable to assume that the health of the user or other persons may be endangered.