



Chipsmall Limited consists of a professional team with an average of over 10 year of expertise in the distribution of electronic components. Based in Hongkong, we have already established firm and mutual-benefit business relationships with customers from,Europe,America and south Asia,supplying obsolete and hard-to-find components to meet their specific needs.

With the principle of “Quality Parts,Customers Priority,Honest Operation,and Considerate Service”,our business mainly focus on the distribution of electronic components. Line cards we deal with include Microchip,ALPS,ROHM,Xilinx,Pulse,ON,Everlight and Freescale. Main products comprise IC,Modules,Potentiometer,IC Socket,Relay,Connector.Our parts cover such applications as commercial,industrial, and automotives areas.

We are looking forward to setting up business relationship with you and hope to provide you with the best service and solution. Let us make a better world for our industry!



Contact us

Tel: +86-755-8981 8866 Fax: +86-755-8427 6832

Email & Skype: info@chipsmall.com Web: www.chipsmall.com

Address: A1208, Overseas Decoration Building, #122 Zhenhua RD., Futian, Shenzhen, China



TLE7186F

System IC for B6 motor drives

Data Sheet

Rev. 1.2, 2016-01-28

Automotive Power

Table of Contents

	Table of Contents	2
1	Overview	4
2	Block Diagram	5
3	Pin Configuration	6
3.1	Pin Assignment TLE7186F	6
3.2	Pin Definitions and Functions	7
4	General Product Characteristics	9
4.1	Absolute Maximum Ratings	9
4.2	Functional Range	10
4.3	Thermal Resistance	11
4.4	Default State of Inputs	11
5	MOSFET Driver	12
5.1	Inputs and Dead Time	12
5.2	Output Stages	12
5.3	Bootstrap Principle	13
5.4	Currents at SH pins	13
5.5	Electrical Characteristics	13
6	Shunt Signal Conditioning	16
6.1	Electrical Characteristics	16
7	5 V Low Drop Voltage Regulator	18
7.1	Electrical Characteristics	18
8	Interface, VDH Switch and $\overline{\text{INH}}$ Digital Output	21
8.1	PWM Interface (IFMA)	21
8.2	VDHS Switch	22
8.3	Digital Output $\overline{\text{INH}}$ D	22
8.4	Electrical Characteristics	22
9	Description of Modes, Protection and Diagnostic Functions	24
9.1	Description of modes	24
9.2	Protection and Diagnosis Functions	27
9.2.1	Over Temperature Shut Down (OTSD)	27
9.2.2	Over Temperature Prewarning (OTPW)	27
9.2.3	Analog Temperature Monitoring	27
9.2.4	VS Under Voltage Lockout (VS_UVLO)	28
9.2.5	VDD Under Voltage Diagnosis (VDD_UVD)	28
9.2.6	VDD Under Voltage Shut Down (VDD_UVSD)	28
9.2.7	VREG Under Voltage Diagnosis (VREG_UVD)	28
9.2.8	VREG Under Voltage Shut Down (VREG_UVSD)	29
9.2.9	IOV and VDH Over Voltage Shut Down (IOV_OVSD, VDH_OVSD)	29
9.2.10	Dead Time and Shoot Through Protection	29
9.2.11	Short Circuit Protection (SCP)	30
9.2.12	SCDL Pin Open Detection (SCDL_open)	30
9.2.13	Over Current Shut Down (OCSD)	30
9.2.14	VDD Current Limitation	30
9.2.15	Passive Gxx Clamping	30
9.3	$\overline{\text{ERR}}$ Pin	30

Table of Contents

9.4	Electrical Characteristics	32
10	Phase voltage feedback	35
10.1	Electrical Characteristics	35
11	Application Description	36
12	Package Outlines	37
13	Revision History	38



1 Overview

Features

- Drives 6 N-Channel Power MOSFETs
- Integrated 5V Vreg-Controller to power μC
- Integrated switch for VDH voltage
- Separate control input for each MOSFET
- Adjustable dead time
- Shoot through protection
- Analog adjustable Short Circuit Protection levels
- Low quiescent current mode
- 1 bit diagnosis $\overline{\text{ERR}}$
- Over Temperature shut down and analog temperature output
- Over Temperature pre-warning
- Under Voltage shut down
- Adjustable Over Voltage shut down
- Current sense OpAmp
- Over current shut down based on Current sense OpAmp, fixed shut down level
- 0 ...94% duty cycle at 25 kHz PWM frequency
- Digital phase voltage feedback
- Green Product (RoHS compliant)
- AEC Qualified



PG-VQFN-48

Description

The TLE7186F is a system IC for Brushless Motor Control. It incorporates a voltage supply for a μC , a bridge driver for a B6 configuration, an application typical PWM interface and some other smaller features. Target is to reduce the number of discrete components in typical BLDC automotive applications and give enough flexibility for custom specific adaptations.

It works with 3-phase motors and brush DC motors. Its exposed pad package allows the usage even at high ambient temperatures.

Type	Package	Marking
TLE7186F	PG-VQFN-48	TLE7186F

2 Block Diagram

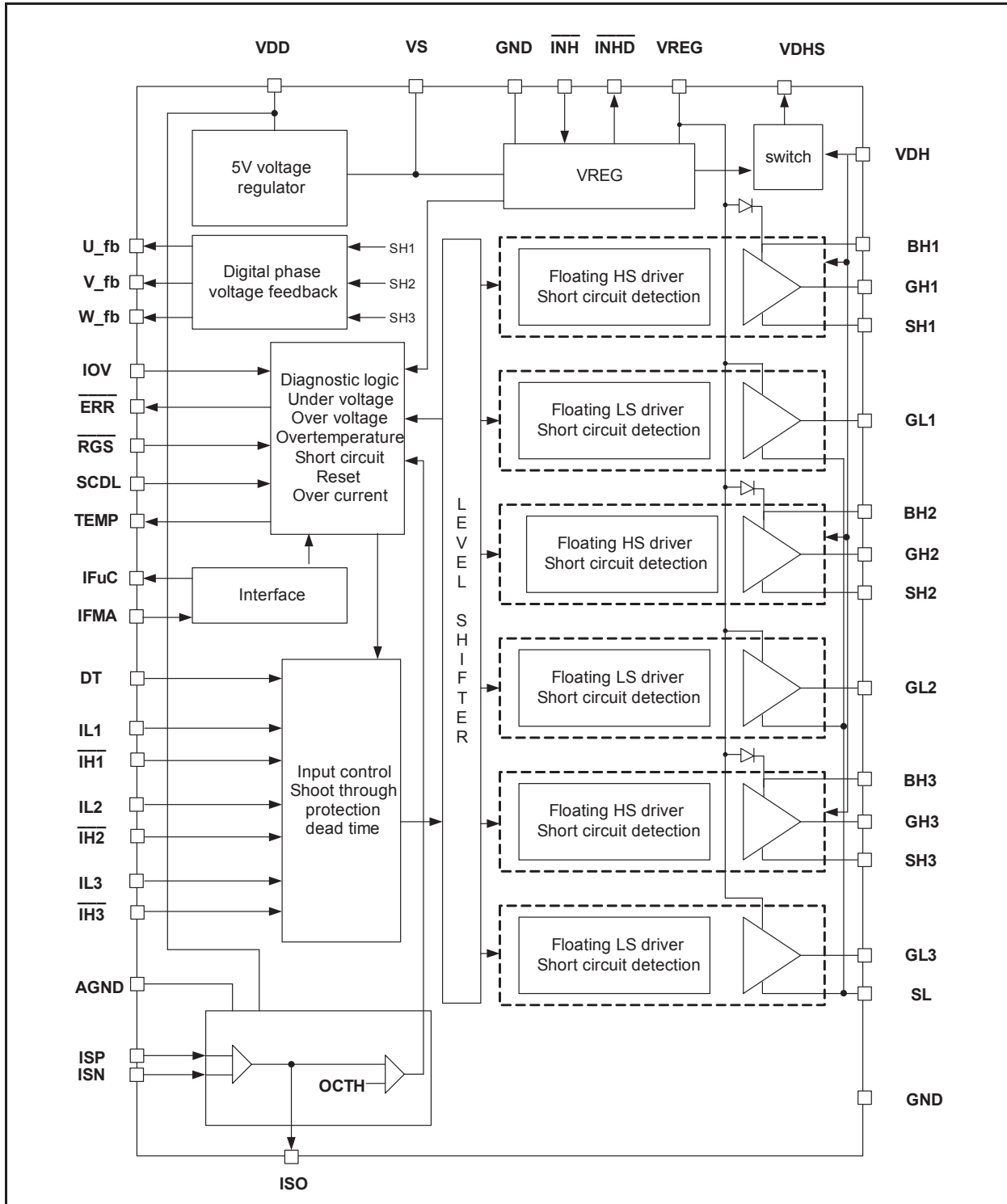

Figure 1 Block Diagram

3 Pin Configuration

3.1 Pin Assignment TLE7186F

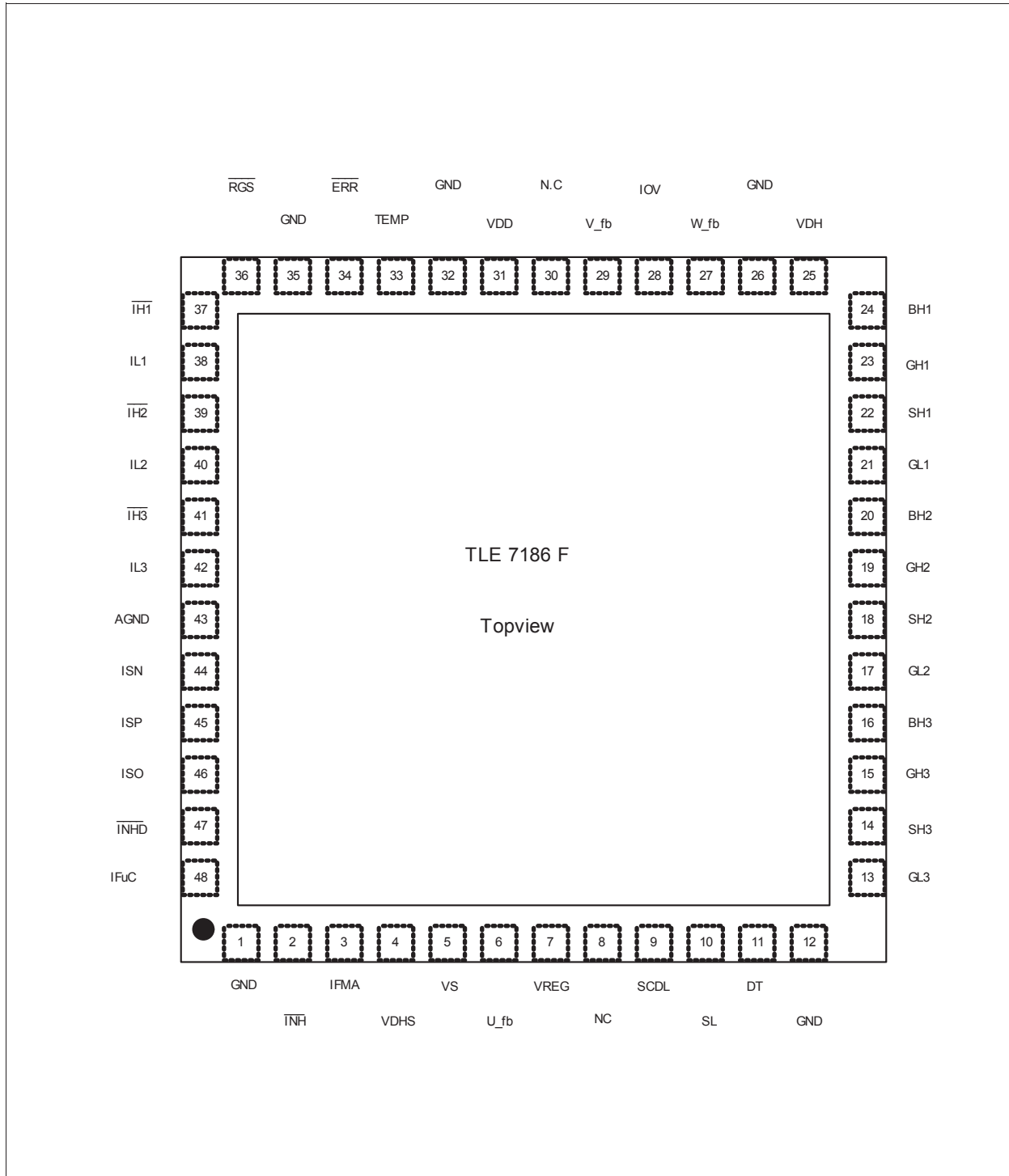

Figure 2 Pin Configuration

3.2 Pin Definitions and Functions

Pin	Symbol	Function
5	VS	Supply Pin
7	VREG	Output of supply for driver output stages - connect to capacitor
31	VDD	Output of 5V supply for μ C - connect to capacitor
2	$\overline{\text{INH}}$	Input pin wake up the complete system IC
47	$\overline{\text{INH}}\overline{\text{D}}$	Digital output 5V for $\overline{\text{INH}}$ state (high when $\overline{\text{INH}}$ is high)
4	VDHS	Switched output of VDH voltage; switch open in sleep mode
33	TEMP	Output pin for analog temperature signal
36	$\overline{\text{RGS}}$	Reset and Go-to-Sleep input pin for reset of error registers, set HIGH to avoid to go-to-sleep
38	IL1	Input for low side switch 1 (active high)
37	$\overline{\text{IH}}1$	Input for high side switch 1 (active low)
40	IL2	Input for low side switch 2 (active high)
39	$\overline{\text{IH}}2$	Input for high side switch 2 (active low)
42	IL3	Input for low side switch 3(active high)
41	$\overline{\text{IH}}3$	Input for high side switch 3(active low)
11	DT	Input pin for adjustable dead time function, connect to GND via resistor
9	SCDL	Analog input pin for adjustable Short Circuit Detection function, connect to voltage divider
28	IOV	Input pin for Over Voltage detection.
34	$\overline{\text{ERR}}$	Open drain error output
25	VDH	Voltage input common drain high side for short circuit detection
24	BH1	Pin for + terminal of the bootstrap capacitor of phase 1
23	GH1	Output pin for gate of high side MOSFET 1
22	SH1	Pin for source connection of high side MOSFET 1
21	GL1	Output pin for gate of low side MOSFET 1
20	BH2	Pin for + terminal of the bootstrap capacitor of phase 2
19	GH2	Output pin for gate of high side MOSFET 2
18	SH2	Pin for source connection of high side MOSFET 2
17	GL2	Output pin for gate of low side MOSFET 2
16	BH3	Pin for + terminal of the bootstrap capacitor of phase 3
15	GH3	Output pin for gate of high side MOSFET 3
14	SH3	Pin for source connection of high side MOSFET 3
13	GL3	Output pin for gate of low side MOSFET 3
10	SL	Pin for common source connection of low side MOSFETs
44	ISN	Input for OpAmp - terminal
45	ISP	Input for OpAmp + terminal
46	ISO	Output of OpAmp
43	AGND	Analog GND for Opamp and analog temperature output
3	IFMA	Interface to master ECU (used for wake up)
48	IFuC	Interface to μ C

Pin Configuration

Pin	Symbol	Function
6	U_fb	Digital phase voltage feedback output of SH1
29	V_fb	Digital phase voltage feedback output of SH2
27	W_fb	Digital phase voltage feedback output of SH3
1	GND	Ground pin
12	GND	Ground pin
26	GND	Ground pin
32	GND	Ground pin
35	GND	Ground pin
8	NC	connect to GND
30	NC	connect to GND

Exposed pad to be connected to GND

4 General Product Characteristics

4.1 Absolute Maximum Ratings

Absolute Maximum Ratings ¹⁾

$T_j = -40\text{ °C}$ to $+150\text{ °C}$; all voltages with respect to ground, positive current flowing into pin (unless otherwise specified)

Pos.	Parameter	Symbol	Limit Values		Unit	Conditions
			Min.	Max.		
Voltages						
4.1.1	Voltage range at VS, IFMA, $\overline{\text{INH}}$, IOV	V_{VS1}	-0.3	45	V	–
4.1.2	Voltage range at IFMA, $\overline{\text{INH}}$	V_{IFMA}	-6.0	45	V	$R \geq 10\text{k}\Omega$
4.1.3	Voltage range at VS	V_{VS2}	-3.0	45	V	$R_{\text{VS}} \geq 4.7\Omega$; 60s, 5x;
4.1.4	Voltage range at VS	V_{VS3}	-3.0	45	V	$R_{\text{VS}} \geq 2.0\Omega$;; 200ms, 5x;
4.1.5	Voltage range at VREG output	V_{VREG}	-0.3	15	V	
4.1.6	Voltage range at VDH, VDHS	V_{VDHx}	-0.3	55	V	–
4.1.7	Voltage range at VDH	V_{VDH1}	-3.0	55	V	With $R_{\text{VDH}} \geq 10\Omega$; 60s, 5x; $T_j \leq 150\text{ °C}$
4.1.8	Voltage range at IHx, ILx, $\overline{\text{RGS}}$, $\overline{\text{ERR}}$, IFuC, TEMP, DT, VDD, ISO, $\overline{\text{INH}}$, SCDL, U_fb, V_fb, W_fb	V_{DP}	-0.3	6	V	–
4.1.9	Voltage range at ISP, ISN	V_{OPI}	-5.0	5.0	V	–
4.1.10	Voltage difference between ISP and ISN	V_{OPD}	-5.0	5.0	V	
4.1.11	Voltage range at BHx	V_{BH}	-0.3	55	V	–
4.1.12	Voltage range at GHx	V_{GH}	-0.3	55	V	–
4.1.13	Voltage range at GHx	V_{GHP}	-7.0	55	V	$t_p < 1\mu\text{s}$; $f=50\text{kHz}$
4.1.14	Voltage range at SHx	V_{SH}	-2.0	45	V	–
4.1.15	Voltage range at SHx	V_{SHP}	-7.0	45	V	$t_p < 1\mu\text{s}$; $f=50\text{kHz}$
4.1.16	Voltage range at GLx	V_{GL}	-0.3	18	V	–
4.1.17	Voltage range at GLx	V_{GLP}	-7.0	18	V	$t_p < 0.5\mu\text{s}$; $f=50\text{kHz}$
4.1.18	Voltage range at SL	V_{SL}	-0.3	5.0	V	–
4.1.19	Voltage range at SL	V_{SLP}	-7.0	5.0	V	$t_p < 0.5\mu\text{s}$; $f=50\text{kHz}$
4.1.20	Voltage difference Gxx-Sxx	V_{GS}	-0.3	15	V	–
4.1.21	Voltage difference BHx-SHx	V_{BS}	-0.3	15	V	–
4.1.22	Minimum bootstrap capacitor C_{BS}	C_{BS}	330	–	nF	-10% tolerance allowed
4.1.23	Minimum buffer capacitor C_{VREG}	C_{VREG}	1	–	μF	
4.1.24	Maximum load capacitance for voltage feedback output X_FB	$C_{\text{X_FB}}$	–	25	pF	–

Temperatures

4.1.25	Junction temperature	T_j	-40	150	°C	–
--------	----------------------	-------	-----	-----	----	---

Absolute Maximum Ratings (cont'd)¹⁾

$T_j = -40\text{ °C}$ to $+150\text{ °C}$; all voltages with respect to ground, positive current flowing into pin (unless otherwise specified)

Pos.	Parameter	Symbol	Limit Values		Unit	Conditions
			Min.	Max.		
4.1.26	Storage temperature	T_{stg}	-55	150	°C	–
4.1.27	Case temperature ²⁾	T_{Case}	–	145	°C	–

ESD Susceptibility

4.1.28	ESD Resistivity ³⁾	V_{ESD}	-2	+2	kV	–
4.1.29	CDM	V_{CDM}	–	500	V	–

1) Not subject to production test, specified by design.

2) Calculation based on T_{jmax} , R_{thJC} and the assumption of 1W power dissipation

3) ESD susceptibility HBM according to EIA/JESD 22-A 114B

Note: Stresses above the ones listed here may cause permanent damage to the device. Exposure to absolute maximum rating conditions for extended periods may affect device reliability.

Note: Integrated protection functions are designed to prevent IC destruction under fault conditions described in the data sheet. Fault conditions are considered as "outside" normal operating range. Protection functions are not designed for continuous repetitive operation.

4.2 Functional Range

Pos.	Parameter	Symbol	Limit Values		Unit	Conditions
			Min.	Max.		
4.2.1	Supply voltage at VS	V_{VS}	6.0	45	V	below 7V reduced functionality ^{1) 2)}
4.2.2	Quiescent current ($I_{VS} + I_{VDH} + I_{IFMA}$)	I_Q	–	50	µA	$V_S < 16V$; sleep mode $V_{VS} = V_{VDH} = V_{IFMA}$
4.2.3	Supply current at VS (device enabled)	$I_{VS(0)}$	–	19	mA	$V_S = 8...18V$; no load ³⁾ ; $f_{PWM} = 25kHz$;
4.2.4	Duty cycle HS	D_{HS}	0	94	%	$f_{PWM} = 25kHz$;
4.2.5	Duty cycle LS	D_{LS}	0	100	%	continuous operation
4.2.6	Junction temperature	T_J	-40	150	°C	–

1) MOS driver output deactivated and ERROR pin set to low if VREG is lower UVVR

2) MOS driver output stage will operate at $V_S = 6.7V$ with 5mA load current at VREG

3) no load at VDD, ERR, ISO, IFµC, VDHS, GXX, TEMP, DT

The limitations in the PWM frequency are given by thermal constraints and limitations in the duty cycle (charging time of bootstrap capacitor).

All maximum ratings have to be considered

All basic functions will work between $T_j = 150\text{ °C}$ and Over Temperature shut down. In this temperature range, the parameters might leave the specified range.

Note: Within the functional range the IC operates as described in the circuit description. The electrical characteristics are specified within the conditions given in the related electrical characteristics table.

4.3 Thermal Resistance

Note: This thermal data was generated in accordance with JEDEC JESD51 standards. For more information, go to www.jedec.org.

Pos.	Parameter	Symbol	Limit Values			Unit	Conditions
			Min.	Typ.	Max.		
4.3.1	Junction to Case ¹⁾	R_{thJC}	–	–	5	K/W	–
4.3.2	Junction to Ambient ¹⁾	R_{thJA}	–	29	–	K/W	²⁾

1) Not subject to production test, specified by design.

2) Specified R_{thJA} value is according to Jedec JESD51-2,-5,-7 at natural convection on FR4 2s2p board; The Product (Chip+Package) was simulated on a 76.2 x 114.3 x 1.5 mm board with 2 inner copper layers (2 x 70µm Cu, 2 x 35µm Cu). Where applicable a thermal via array under the exposed pad contacted the first inner copper layer.

4.4 Default State of Inputs

Table 1 Default State of Inputs

Characteristic	State	Remark
Default state of \overline{ILx} (if \overline{ILx} left open -pull down)	Low	Low side MOSFETs off
Default state of \overline{IHx} (if \overline{IHx} left open - pull up)	High	High side MOSFETs off
Default state of \overline{RGS} (if \overline{RGS} left open - pull down)	Low	Error signal is reset and the TLE7186F goes to sleep
Default state of \overline{INH} (if \overline{INH} left open - pull down)	Low	no wake up by \overline{INH}
Default state of \overline{SCDL} (if \overline{SCDL} left open - pull up)	High	Error signal is set; all MOSFETs switched off
Default state of \overline{IFMA} (if \overline{IFMA} left open - pull up) ¹⁾	High	no wake up by \overline{IFMA}
Default state of \overline{IOV} (if \overline{IOV} left open - pull down)	Low	no Over Voltage detection by \overline{IOV}
Default state of \overline{DT} (if \overline{DT} left open)	max. dead time	max. dead time

1) external capacitance < 25pF

5 MOSFET Driver

5.1 Inputs and Dead Time

There are 6 independent control inputs to control the 6 MOSFETs individually. However, the control inputs for the High Side MOSFETs IHx are inverted. Hence, the control inputs for High Side IHx and Low Side MOSFETs ILx of the same half bridge can be tight together to control one half bridge by one control signal. To avoid shoot through currents within the half bridges, a dead time is provided by the TLE7186F.

For more details about the dead time please see [Chapter 9.2.10](#)

5.2 Output Stages

The 3 low side and 3 high side powerful push-pull output stages of the TLE7186F are all floating blocks.

All 6 output stages have the same output power and thanks to the bootstrap principle used, all MOSFETs can be switched up to high frequencies.

Each output stage has its own short circuit detection block. For more details about short circuit detection see [Chapter 9.2.11](#).¹⁾

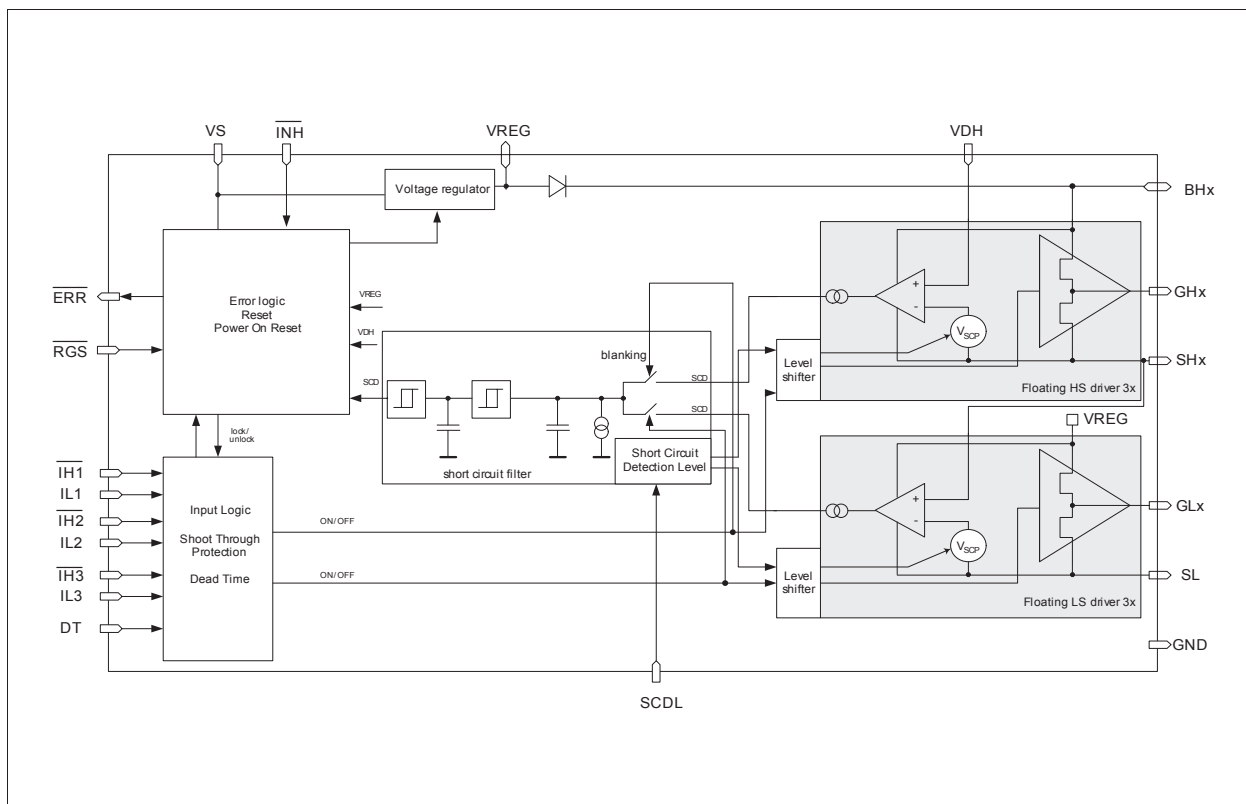

Figure 3 Block Diagram of Driver Stages including Short Circuit Detection

1) The high side outputs are not designed to be used for low side MOSFETs; the low side outputs are not designed to be used for high side MOSFETs

5.3 Bootstrap Principle

The TLE7186F provides a bootstrap based supply for its high side output stages. The benefit of this principle is a fast switching of the high side switches - supporting active freewheeling in high side.

The bootstrap capacitors are charged by switching on the external low side MOSFETs connecting the bootstrap capacitor to GND. Under this condition the bootstrap capacitor will be charged from the VREG capacitor. If the low side MOSFET is switched off and the high side MOSFET is switched on, the bootstrap capacitor will float together with the SHx voltage to the supply voltage of the bridge. Under this condition the supply current of the high side output stage will discharge the bootstrap capacitor. This current is specified. The size of the capacitor together with this current will determine how long the high side MOSFET can be kept on without recharging the bootstrap capacitor.

When all external MOSFETs are switched off, the SHx voltage can be undefined. Under this condition, the bootstrap capacitors can be discharged, dependent on the SHx voltage.

5.4 Currents at SH pins

The currents at the SH pins can be used for diagnostic purposes to check the health state of the power stage.

The simplified structure related to the SH currents the TLE7186F is described by [Figure 4](#).

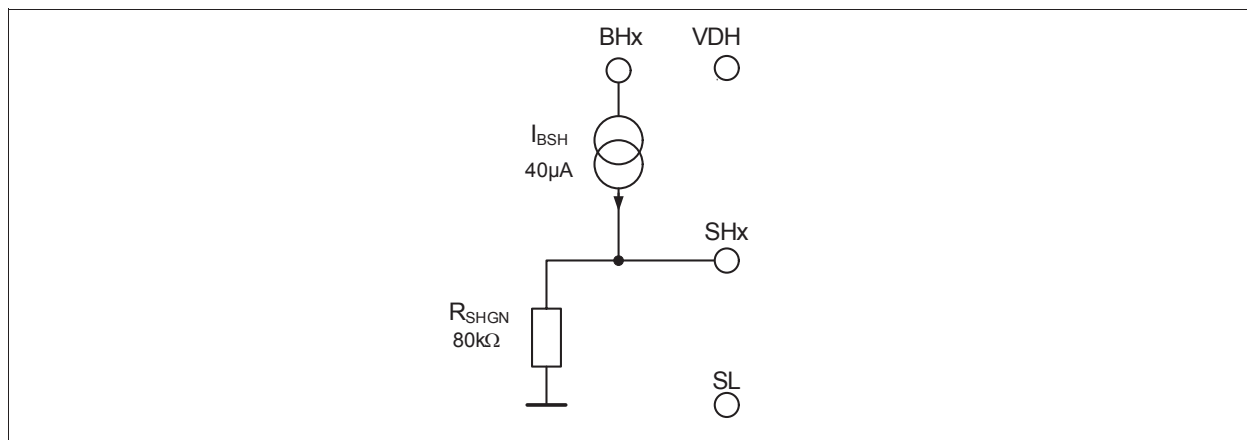

Figure 4 Block Diagram of SHx pin configuration

5.5 Electrical Characteristics

Electrical Characteristics MOSFET Drivers

$V_S = 7.0$ to 33 V, $T_j = -40$ °C to $+150$ °C all voltages with respect to ground, positive current flowing into pin (unless otherwise specified)¹⁾

Pos.	Parameter	Symbol	Limit Values			Unit	Conditions
			Min.	Typ.	Max.		
Inputs							
5.5.1	Low level input voltage of ILx; \overline{IHx}	$V_{I,LL}$	–	–	1.6	V	–
5.5.2	High level input voltage of ILx; \overline{IHx}	$V_{I,HL}$	2.8	–	–	V	–
5.5.3	Input hysteresis of \overline{IHx} ; $ILx^{2)}$	d_{VI}	100	–	–	mV	–
5.5.4	IHx pull-up resistors to VDD	R_{IH}	28.5	–	76.5	kΩ	–
5.5.5	ILx pull-down resistors to GND	R_{IL}	178.5	–	564	kΩ	–

Electrical Characteristics MOSFET Drivers

$V_S = 7.0$ to 33 V, $T_j = -40$ °C to $+150$ °C all voltages with respect to ground, positive current flowing into pin (unless otherwise specified)¹⁾

Pos.	Parameter	Symbol	Limit Values			Unit	Conditions
			Min.	Typ.	Max.		
MOSFET driver output							
5.5.6	Output source resistance	R_{Sou}	2	–	13.5	Ω	$I_{load}=20\text{mA}$
5.5.7	Output sink resistance	R_{Sink}	2	–	9	Ω	$I_{load}=20\text{mA}$
5.5.8	High level output voltage Gxx vs. Sxx	V_{Gxx1}	–	11	14	V	13,5V $\leq V_{VS} \leq 45\text{V}^3$, $V_{IOV} < V_{OVIOV}$, $V_{VDH} < V_{OVVDH}$ $I_{load}=37,5\text{mA}$
5.5.9	High level output voltage GHx vs. SHx ²⁾	V_{Gxx2}	6	–	–	V	$V_{VS}=8\text{V}$, $C_{load}=20\text{nF}$, dc=95%; $f_{PWM}=20\text{kHz}$
5.5.10	High level output voltage GHx vs. SHx ²⁾⁴⁾	V_{Gxx3}	6 $+V_{diode}$	–	–	V	$V_{VS}=8\text{V}$, $C_{load}=20\text{nF}$, dc=95%; $f_{PWM}=20\text{kHz}$; passive freewheeling
5.5.11	High level output voltage GLx vs. GND	V_{Gxx4}	6.7	–	–	V	$V_{VS}=8\text{V}$, $C_{load}=20\text{nF}$, dc=95%; $f_{PWM}=20\text{kHz}$;
5.5.12	Rise time $T_j = -40^\circ\text{C}$ $T_j = 150^\circ\text{C}$	t_{rise}	100 150	– –	230 350	ns	$C_{Load}=11\text{nF}$; $R_{Load}=1\Omega$ $V_{VS}=7\text{V}$
5.5.13	Fall time $T_j = -40^\circ\text{C}$ $T_j = 150^\circ\text{C}$	t_{fall}	80 150	– –	210 290	ns	20-80%
5.5.14	High level output voltage (in passive clamping)	V_{GUV}	–	–	1.2	V	sleep mode or $VS_UVLO^2) 5)$
5.5.15	Pull-down resistor at BHx to GND	R_{BHUV}	–	–	80	k Ω	
5.5.16	Pull-down resistor at VREG to GND	R_{VRUV}	–	–	30	k Ω	
5.5.17	Bias current into BHx	I_{BH}	–	–	150	μA	$V_{BHx}-V_{SHx}=5\dots13\text{V}$; no switching
5.5.18	Current between BHx and SHx	I_{BSH}	15	40	60	μA	$V_{BHx}-V_{SHx}=5\dots13\text{V}$; $V_{SHx} = \text{GND}$
5.5.19	Resistor between SHx and GND	R_{SHGN}	48	80	112	k Ω	
5.5.20	Bias current out of SL	I_{SL}	–	–	2	mA	$0\text{V} \leq V_{SH} \leq V_S + 1$ V; no switching; $V_{CBS} > 5\text{V}$

Electrical Characteristics MOSFET Drivers

$V_S = 7.0$ to 33 V, $T_j = -40$ °C to $+150$ °C all voltages with respect to ground, positive current flowing into pin (unless otherwise specified)¹⁾

Pos.	Parameter	Symbol	Limit Values			Unit	Conditions
			Min.	Typ.	Max.		
5.5.21	Input propagation time (low on)	$t_{P(ILN)}$	50	–	200	ns	$C_{Load}=11nF$; $R_{Load}=1\Omega$
5.5.22	Input propagation time (low off)	$t_{P(ILF)}$	50	–	200	ns	
5.5.23	Input propagation time (high on)	$t_{P(IHN)}$	50	–	200	ns	
5.5.24	Input propagation time (high off)	$t_{P(IHF)}$	50	–	200	ns	
5.5.25	Absolute input propagation time difference between above propagation times	$t_{P(diff)}$	–	–	100	ns	

VREG

5.5.26	VREG output voltage	V_{VREG}	11	12.5	14	V	$V_{VS} \geq 13,5V$; $I_{load}=37,5mA$
5.5.27	VREG over current limitation	$I_{VREGOCL}$	100	–	500	mA	no activation of error; $V_{VREG} > V_{VRSD}$
5.5.28	Voltage drop between Vs and VREG	V_{VsVREG}	–	–	0.5	V	$V_{VS} \geq 7V$; $I_{load}=37,5mA$; Ron operation

- 1) R_{Load} and C_{Load} in series
- 2) Not subject to production test; specified by design
- 3) Values above 33V not subjected to production test; specified by design
- 4) V_{diode} is the bulk diode of the external low side MOSFET
- 5) see [Chapter 9.2.15](#)

6 Shunt Signal Conditioning

The TLE7186F incorporates a fast and precise operational amplifier for conditioning and amplification of the current sense shunt signal. The gain of the OpAmp is adjustable by external resistors within a range higher than 5. The usage of higher gains in the application might be limited by required settling time and band width.

It is recommended to apply a small offset to the OpAmp, to avoid operation close to the lower rail at low currents. The output of the OpAmp ISO is not short-circuit proof.

In addition to the integrated operational amplifier, the TLE7186F incorporates a comparator to detect over current situations. The output voltage V_{ISO} is compared to a reference voltage V_{OCTH} close to the upper rail of the 5V OpAmp supply (VDD). If V_{ISO} reaches this level an error is set.

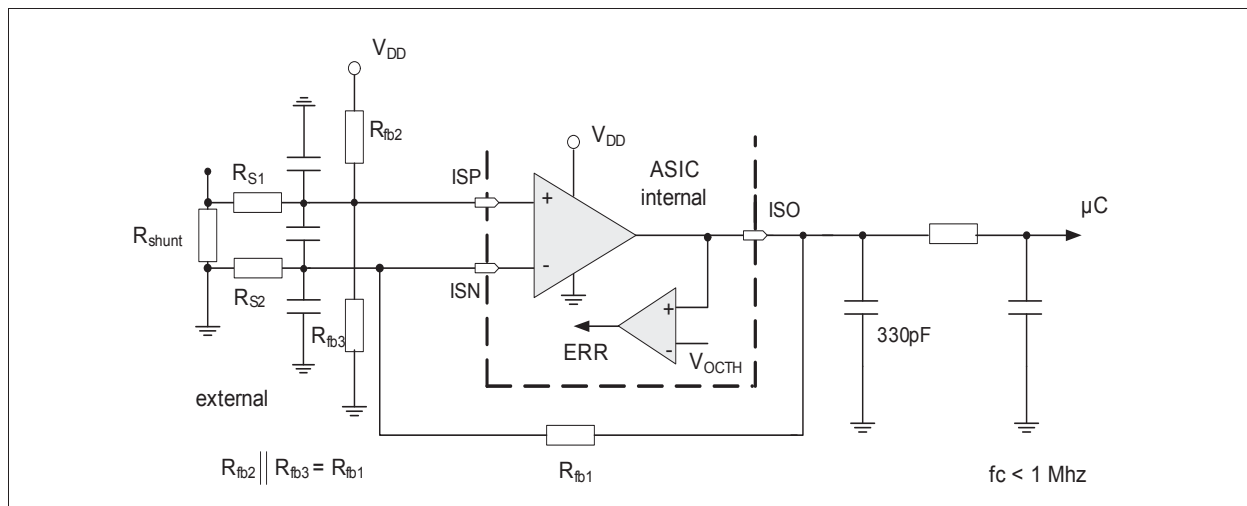

Figure 5 Shunt Signal Conditioning Block Diagram and Over Current Limitation

Over current shut down see [Chapter 9.2.13](#).

6.1 Electrical Characteristics

Electrical Characteristics - Current sense signal conditioning

$V_S = 6.0$ to 33 V, $T_j = -40$ °C to $+150$ °C, gain = 5 to 75, all voltages with respect to ground, positive current flowing into pin (unless otherwise specified)¹⁾

Pos.	Parameter	Symbol	Limit Values			Unit	Conditions
			Min.	Typ.	Max.		
6.1.1	Series resistors	R_S	100	500	1000	Ω	—
6.1.2	Feedback resistor	R_{fb}	2000	7500	—	Ω	—
6.1.3	Resistor ratio (gain ratio), max. gain limited by settling time	$R_{fb/RS}$	5	—	—	—	$R_L > 3k\Omega$
6.1.4	Input differential voltage (ISP - ISN)	V_{IDR}	-800	—	800	mV	—
6.1.5	Input voltage (Both Inputs - GND) (ISP - GND) or (ISN - GND)	V_{LL}	-800	—	2000	mV	—
6.1.6	Input offset voltage of the I-DC link OpAmp, including temperature drift	V_{IO}	—	—	+/-2	mV	$R_S = 500\Omega$; $V_{CM} = 0V$; $V_{ISO} = 1.65V$;
6.1.7	Input bias current (ISN, ISP to GND)	I_{IB}	-300	—	—	μA	$V_{CM} = 0V$; $V_{ISO} = open$

Electrical Characteristics - Current sense signal conditioning (cont'd)

$V_S = 6.0$ to 33 V, $T_j = -40$ °C to $+150$ °C, gain = 5 to 75, all voltages with respect to ground, positive current flowing into pin (unless otherwise specified)¹⁾

Pos.	Parameter	Symbol	Limit Values			Unit	Conditions
			Min.	Typ.	Max.		
6.1.8	High level output voltage of ISO	V_{OH}	$V_{VDD} - 0.2$	–	V_{VDD}	V	$I_O = -3$ mA
6.1.9	Low level output voltage of ISO	V_{OL}	-0.1	–	0.2	V	$I_O = 3$ mA
6.1.10	Guaranteed output current capability	I_{GOC}	5	–	–	mA	–
6.1.11	Differential input resistance ²⁾	R_I	100	–	–	k Ω	–
6.1.12	Common mode input capacitance ²⁾	C_{CM}	–	–	10	pF	10 kHz
6.1.13	Common mode rejection ratio at DC CMRR = $20 \cdot \log((V_{out_diff}/V_{in_diff}) \cdot (V_{in_CM}/V_{out_CM}))$	C_{MRR}	80	100	–	dB	–
6.1.14	Common mode suppression ³⁾²⁾ with CMS = $20 \cdot \log(V_{out_CM}/V_{in_CM})$ Freq = 100 kHz Freq = 1 MHz Freq = 10 MHz	C_{MS}	–	62 43 33	–	dB	$V_{IN} = 360$ mV * $\sin(2 \cdot \pi \cdot \text{freq} \cdot t)$; $R_S = 500$ Ω ; $R_{fb} = 7500$ Ω
6.1.15	Slew rate	$d_{V/dt}$	–	10	–	V/ μ s	Gain ≥ 5 ; $R_L = 1.0$ k Ω ; $C_L = 500$ pF
6.1.16	Large signal open loop voltage gain (DC)	A_{OL}	80	100	–	dB	–
6.1.17	Unity gain bandwidth	G_{BW}	10	20	–	MHz	$R_L = 1$ k Ω ; $C_L = 100$ pF
6.1.18	Phase margin ²⁾	F_M	–	50	–	°	Gain ≥ 5 ; $R_L = 1$ k Ω ; $C_L = 100$ pF
6.1.19	Gain margin ²⁾	A_M	–	12	–	dB	$R_L = 1$ k Ω ; $C_L = 100$ pF
6.1.20	Bandwidth	B_{WG}	1.6	–	–	MHz	Gain = 15; $R_L = 1$ k Ω ; $C_L = 500$ pF; $R_S = 500$ Ω
6.1.21	Output settle time to 98% $R_{fb}/R_S = 15$ $R_{fb}/R_S = 75$	t_{set1}	– –	1 4.6	1.8 8	μ s	$R_L = 1$ k Ω ; $C_L = 500$ pF; $0.3 < V_{ISO} < V_{DD} - 0.3$ V; $R_S = 500$ Ω

1) A minimum capacitance of 100 pF is needed at the output of the OpAmp (parasitic or real capacitor); R_L is the total load resistance including the feedback network; In the application it is not recommended to apply a resistor from the output ISO to GND directly in addition to the feedback network.

2) Not subject to production test; specified by design

3) Without considering any offsets such as input offset voltage, internal mismatch and assuming no tolerance error in external resistors.

7 5 V Low Drop Voltage Regulator

The TLE7186F incorporates a 5V LDO for μC supply. The voltage regulator is protected against Over Temperature by the central temperature sensor (see [Chapter 9.2.1](#) and [Chapter 9.2.2](#)). It has an integrated current limitation and Under Voltage detection.

Parameters for Under Voltage detection see [Chapter 9.2.5](#).

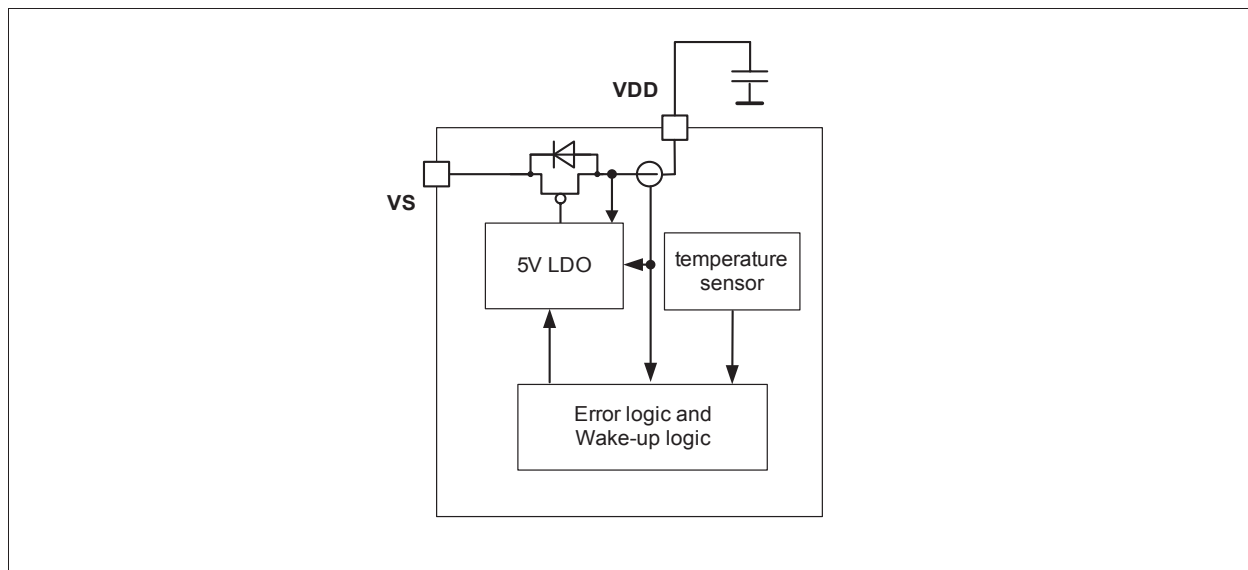

Figure 6 Block diagram of 5V LDO

7.1 Electrical Characteristics

Electrical Characteristics - Current sense signal conditioning

$V_S = 6.0$ to 45 V , $T_j = -40\text{ }^\circ\text{C}$ to $+150\text{ }^\circ\text{C}$, all voltages with respect to ground, positive current flowing into pin (unless otherwise specified)

Pos.	Parameter	Symbol	Limit Values			Unit	Conditions
			Min.	Typ.	Max.		
7.1.1	Output voltage	V_{DD1}	4.85	–	5.25	V	$2\text{mA} \leq I_{\text{load}} \leq 70\text{mA}$; $C_{\text{load}} = 1 \dots 22\mu\text{F}^{1)}$
7.1.2	Output voltage	V_{DD2}	4.90	–	5.20	V	$5\text{mA} \leq I_{\text{load}} \leq 25\text{mA}$; $C_{\text{load}} = 1 \dots 22\mu\text{F}^{1)}$
7.1.3	LDO over current limitation	I_{OCL}	130	–	270	mA	no activation of error by current limitation
7.1.4	Load regulation	D_{VDD}	–	50	100	mV	I_{load} step $0 \dots 20\text{mA}$; $C_{VDD} = 1\mu\text{F}$
7.1.5	Power supply ripple rejection ²⁾	P_{SRR}	50	–	–	dB	100Hz sine wave; $0.5V_{\text{pp}}$ $V_S \geq 7\text{V}$
7.1.6	Power supply ripple rejection ²⁾	P_{SRR}	–	31	–	dB	100Hz sine wave; $0.5V_{\text{pp}}$ $6\text{V} \leq V_S < 7\text{V}$

1) ceramic C with 100nF with ESR < 0.1 Ω in parallel

2) Not subject to production test; specified by design

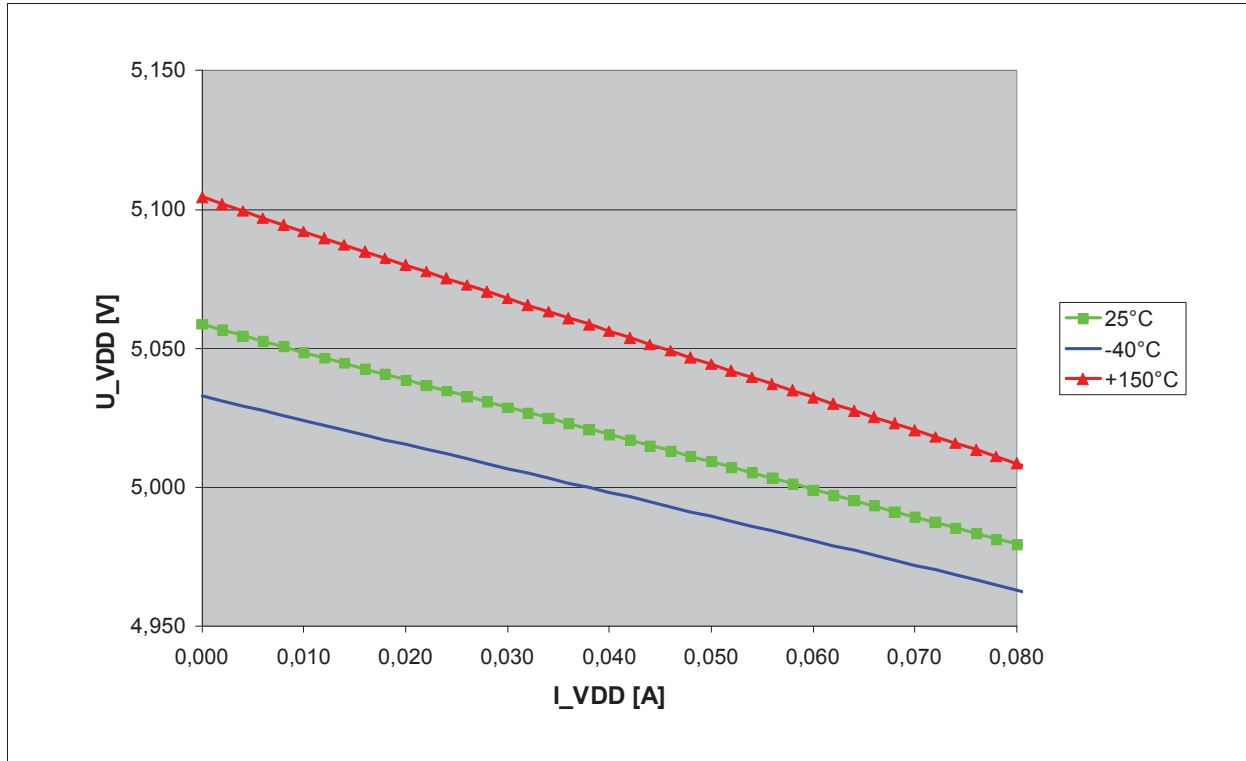

Figure 7 Typ. VDD output voltage vs. load current

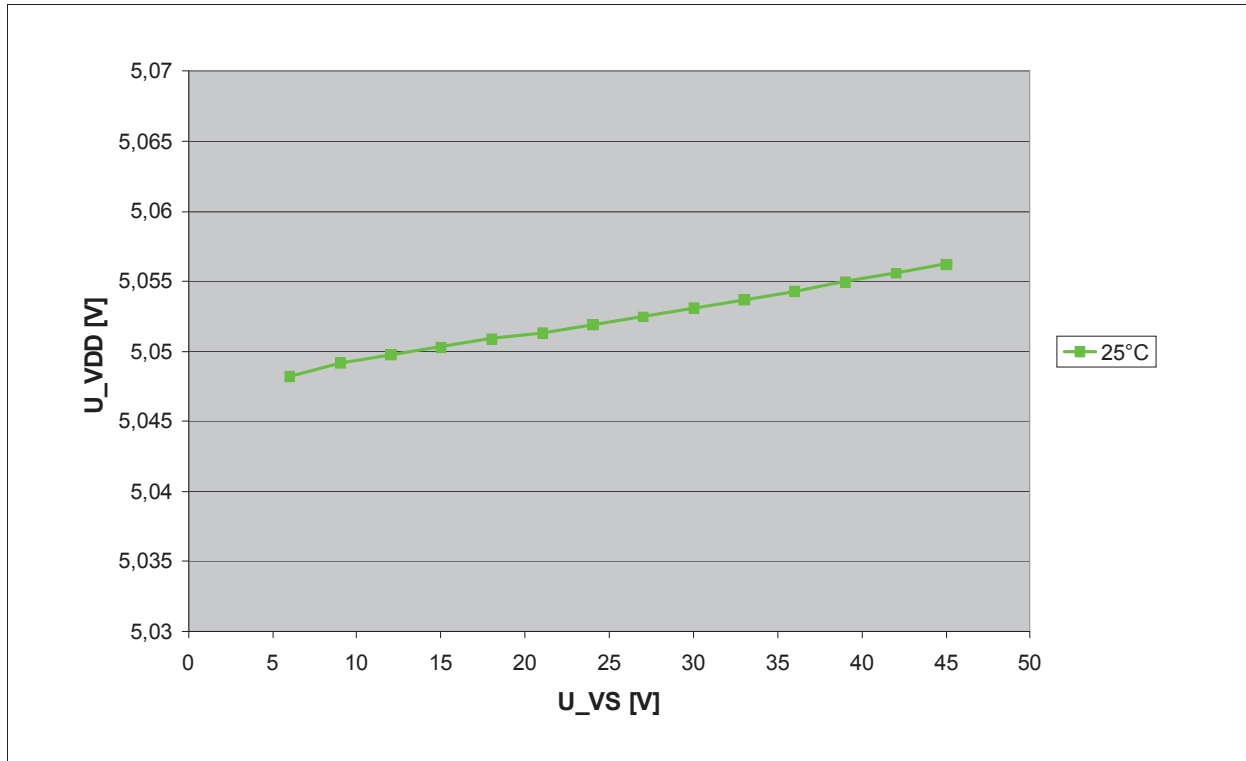

Figure 8 Typ. VDD output voltage vs. supply voltage

8 Interface, VDH Switch and INH Digital Output

8.1 PWM Interface (IFMA)

The TLE7186F has an integrated interface supporting the typical PWM interface between a remote master ECU and the μC . The link to the external master ECU is a single wire communication based on the battery voltage and running typ. with about 10 to 400 Hz. The information is encoded in the duty cycle of the signal.

This communication line requires a signal conditioning to connect to the on board μC .

The integrated circuit supports the incoming data path.

The outgoing data path is formed by external components

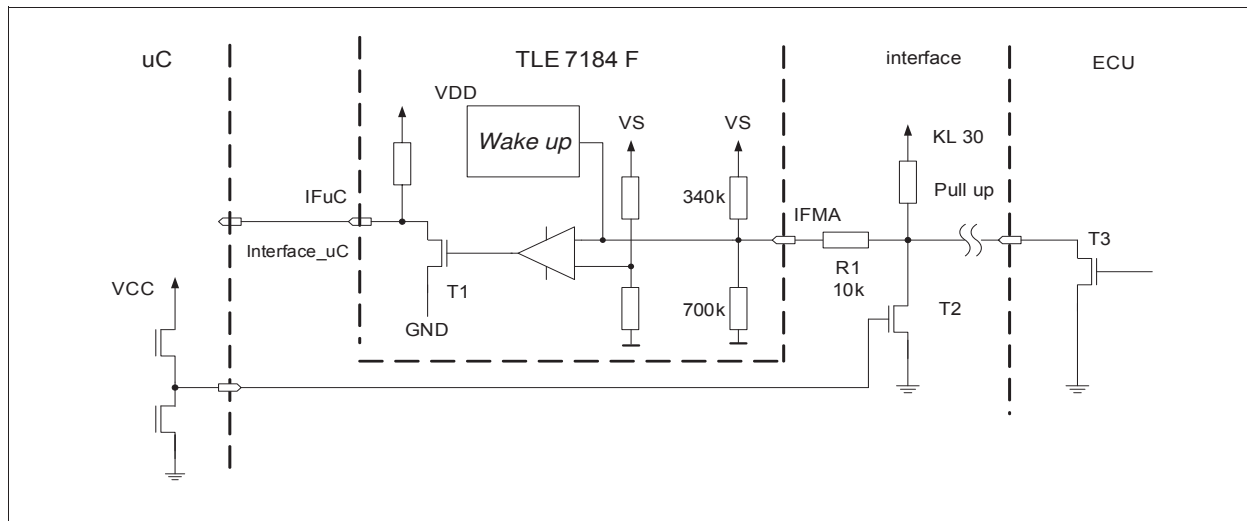

Figure 9 Structure PWM Interface

The integrated circuitry is described in [Figure 9](#).

The main task of this interface is level shifting and protection of the μC .

The IFuC signal is following the IFMA signal, passing the duty cycle information from IFMA to the IFuC.

The μC port is used as input and is listening to the IFuC signal. The voltage at IFMA is monitored. If IFMA is low the IFuC open drain output is switched on - forcing the IFuC signal to low.

If IFMA is high, the IFuC open drain output is deactivated and the IFuC signal is pulled to high by the internal pull-up resistor.

The IFMA input is used as well for wake-up. See [Chapter 9.1](#)

Influence of serial resistor at IFMA pin

As shown in [Figure 9](#) a 10k resistor R1 is recommended to protect the IFMA pin against negative voltage levels coming from the interface signal. The integrated pull down and pull up resistors at the IFMA pin form a voltage divider together with the resistor R1. This will influence the resulting switching level of the IFMA interface in the application compared to the levels specified directly at the IFMA pin.

In this datasheet an additional parameter is provided to calculate the influence of the 10k resistor. The specified IFMA input current divided by V_{VS} allows to calculate the drop over R1 with the following formula:

$$\text{Voltage_drop_over_R1} = \frac{I_{IFMA} * V_{VS}}{V_{VS}} * R1$$

8.2 VDHS Switch

The System IC has an integrated switch connecting the VDH pin to the VDHS pin. This allows to place an external voltage divider for VDH voltage monitoring at the VDHS pin and to disconnect this voltage divider from VDH during sleep mode to assure low current consumption. The VDHS switch is only deactivated when the VDD regulator is switched off.

8.3 Digital Output $\overline{\text{INHD}}$

The System IC provides a digital output $\overline{\text{INHD}}$ showing the logic state of $\overline{\text{INH}}$ (e.g. KL15) after a complete wake-up of the driver (approx. 1ms). The input levels of $\overline{\text{INH}}$ for the $\overline{\text{INHD}}$ output are defined separately from the levels for wake-up. Voltage levels for $\overline{\text{INH}}$ wake-up function please see [Chapter 9.4](#) section Wake-up and go-to-sleep. The output stage consists of an integrated low side switch with a pull-up resistor to VDD.

8.4 Electrical Characteristics

Electrical Characteristics - Protection and diagnostic functions

$V_S = 6.0$ to $20V$, $T_j = -40$ °C to $+150$ °C, all voltages with respect to ground, positive current flowing into pin (unless otherwise specified)

Pos.	Parameter	Symbol	Limit Values			Unit	Conditions
			Min.	Typ.	Max.		
Interface - static parameters							
8.4.1	IFMA input voltage high level (for IF μ C high)	V_{IMHL}	59	–	–	%	of V_{VS} ; IC not in Sleep Mode
8.4.2	IFMA input voltage low level (for IF μ C low)	V_{IMLL}	–	–	46	%	of V_{VS} ; IC not in Sleep Mode;
8.4.3	IFMA input hysteresis (for IF μ C)	V_{IMhy}	0.5	–	9	%	of V_{VS} ; IC not in Sleep Mode
8.4.4	IFMA wake up voltage high level $= V_S - V_{IFMA}$	V_{IMWH}	2	–	4	V	valid in Sleep Mode
8.4.5	IFMA low time to guarantee wake-up	t_{IFlow}	100	–	–	μ s	$V_{VS}=7...20V$
8.4.6	IFMA internal pull-up resistor to V_S	R_{IMu}	210	340	495	k Ω	–
8.4.7	IFMA internal pull-down resistor to GND	R_{IMd}	420	700	980	k Ω	not active in Sleep Mode
8.4.8	IFMA input current related to VS $V_{IFMA} = 59\%$ of V_{VS} $V_{IFMA} = 46\%$ of V_{VS}	I_{IFMA}/V_{VS}	-2.0 -3.0	–	+2.0 +1.0	μ A/V	–
8.4.9	IF μ C output low voltage	V_{luLL}	–	–	0.5	V	no external load
8.4.10	IF μ C internal pull-up resistor to V_{DD}	R_{lu}	8.5	–	23	k Ω	–
Interface - dynamic parameters							
8.4.11	IF μ C duty cycle	d_{lu}	0	–	100	%	–
8.4.12	Propagation time rising edge IF μ C	t_{PRE}	–	–	6	μ s	Including rise time to 80% of V_{VDD} ; $C_{load}=100pF$
8.4.13	Propagation time falling edge IF μ C	t_{PFE}	–	–	5	μ s	Including fall time to 20% of V_{VDD} ; $C_{load}=100pF$

Interface, VDH Switch and INH Digital Output

Electrical Characteristics - Protection and diagnostic functions (cont'd)

$V_S = 6.0$ to $20V$, $T_j = -40$ °C to $+150$ °C, all voltages with respect to ground, positive current flowing into pin (unless otherwise specified)

Pos.	Parameter	Symbol	Limit Values			Unit	Conditions
			Min.	Typ.	Max.		
8.4.14	Deviation between rising and falling IF μ C	t_{PD}	–	–	4	μ s	$C_{load}=100pF$

VDH switch

8.4.15	Ron VDH switch	R_{VDH}	–	–	150	Ω	Load current = 1mA
--------	----------------	-----------	---	---	-----	----------	--------------------

INHD digital output

8.4.16	Low level input voltage \overline{INH} (for INHD=low)	V_{INHDL}	–	–	1.5	V	–
8.4.17	High level input voltage \overline{INH} (for INHD=high)	V_{INHDL}	2.2	–	–	V	–
8.4.18	Input hysteresis of \overline{INH} for $\overline{INHD}^{1)}$	d_{VINHD}	100	–	–	mV	–
8.4.19	\overline{INHD} low level output voltage	V_{INHD}	–	–	0.5	V	no external load
8.4.20	\overline{INHD} Internal pull-up resistor to V_{DD}	R_{INHD}	42.5	–	115	k Ω	–

1) Not subject to production test; specified by design

9 Description of Modes, Protection and Diagnostic Functions

9.1 Description of modes

The operation of TLE7186F can be described by different operation modes

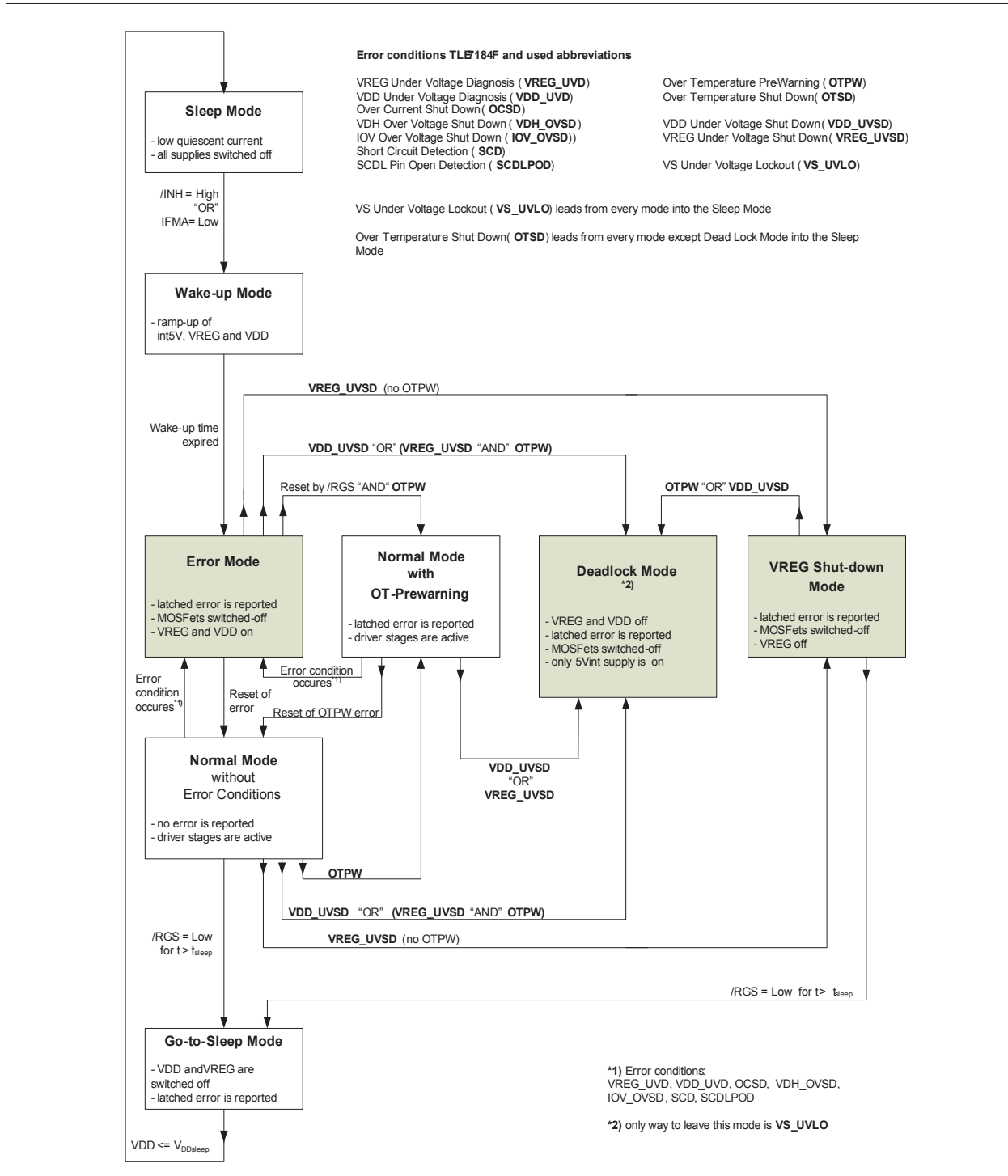

Figure 10 State diagram TLE7186F

Sleep Mode:

The sleep mode is entered if the device is in the Go-to-sleep Mode and the VDD voltage is lower than $V_{DDsleep}$. The complete chip is deactivated beside the wake-up function (see Wake-up Mode). This mode is designed for lowest current consumption from the power net of the car. The passive clamping is active. For details see the description of passive clamping, see [Chapter 9.2.15](#).

The only way to leave the Sleep Mode is to go to the Wake-up Mode.

Wake-up Mode:

The TLE7186F wakes up if \overline{INH} (=KL15) is high or if IFMA is low and V_{VS} is higher than V_{VSLO} .

In this mode all supplies are ramping up. As soon as the internal 5V is available, a so called wake-up timer starts to run. If the IC reaches this state, the wake-up will continue even if the wake-up signals at \overline{INH} or IFMA disappear. The PWM interface (IFMA) is active as soon as the VDD voltage is sufficiently high. During this time it is expected that the supplies are powered up and the μC sets the \overline{RGS} to high. All external MOSFETs are switched off actively or passively. When the wake up timer is expired the IC goes into the Error mode.

In this mode all errors will be ignored beside Over Temperature Shut Down or V_S Under Voltage Lockout.

Error Mode

The Error Mode can be reached in 3 different ways:

1. The device is in Wake-up Mode and the wake up timer expires
2. The device is in Normal Mode and one or more of the following errors occur: VREG Under Voltage Shut Down, VDD Under Voltage Shut Down, Over Current Shut Down, VDH Over Voltage Shut Down, IOV Over Voltage Shut Down, Short Circuit Detection or SCDL Open Detection.
3. The device is in Normal Mode with OT-Prewarning and one or more of the following errors occur: VREG Under Voltage Shut Down, VDD Under Voltage Shut Down, Over Current Shut Down, VDH Over Voltage Shut Down, IOV Over Voltage Shut Down, Short Circuit Detection or SCDL Open Detection.

In this mode an Error is set at the ERROR Pin and all external MOSFETs are actively switched off as long as the bootstrap voltages allows it. The interface is active. VDHS switch is on and the current sense functions are working. VDD and VREG are active. Passive clamping is not active.

The Error mode can be left in the following ways:

1. If no error is present, the IC can be sent to Normal Mode by a reset with the \overline{RGS} pin.
2. If a VREG Under Voltage Shut Down occurs and no Over Temperature Prewarning is present, the device will go to VREG Shut-down Mode.
3. If VDD Under Voltage Shut Down occurs or a VREG Under Voltage Shut Down together with a Over Temperature Prewarning occurs, the device will go into Deadlock Mode.
4. If Over Temperature Prewarning is present, the IC can be sent to Normal Mode with OT-Prewarning by a reset with the \overline{RGS} pin.

Normal Mode

The Normal Mode can be reached in two different ways:

1. The device is in Error Mode, no error is present and a reset is performed by the \overline{RGS} pin.
2. The device is in Normal Mode with OT-Prewarning, the chip temperature is below the OT-Prewarning level and a reset is performed by the \overline{RGS} pin.

In the Normal Mode all functions are active and available with the regular limitations of the bootstrap principle. The gate drive output stages can be controlled with the input pins.

The Normal Mode can be left in 5 ways:

1. The devices goes to the Go-To-Sleep Mode by setting \overline{RGS} to low for a time longer than t_{sleep} .
2. If a Over Temperature Prewarning occurs the device goes into the Normal Mode with OT-Prewarning.