



Chipsmall Limited consists of a professional team with an average of over 10 year of expertise in the distribution of electronic components. Based in Hongkong, we have already established firm and mutual-benefit business relationships with customers from,Europe,America and south Asia,supplying obsolete and hard-to-find components to meet their specific needs.

With the principle of "Quality Parts,Customers Priority,Honest Operation,and Considerate Service",our business mainly focus on the distribution of electronic components. Line cards we deal with include Microchip,ALPS,ROHM,Xilinx,Pulse,ON,Everlight and Freescale. Main products comprise IC,Modules,Potentiometer,IC Socket,Relay,Connector.Our parts cover such applications as commercial,industrial, and automotives areas.

We are looking forward to setting up business relationship with you and hope to provide you with the best service and solution. Let us make a better world for our industry!



Contact us

Tel: +86-755-8981 8866 Fax: +86-755-8427 6832

Email & Skype: info@chipsmall.com Web: www.chipsmall.com

Address: A1208, Overseas Decoration Building, #122 Zhenhua RD., Futian, Shenzhen, China



TLE9834QX

Microcontroller with LIN and Power Switches for Automotive Applications

Data Sheet

Rev. 1.1, 2012-03-08

Edition 2012-03-08

**Published by
Infineon Technologies AG
81726 Munich, Germany**

**© 2012 Infineon Technologies AG
All Rights Reserved.**

Legal Disclaimer

The information given in this document shall in no event be regarded as a guarantee of conditions or characteristics. With respect to any examples or hints given herein, any typical values stated herein and/or any information regarding the application of the device, Infineon Technologies hereby disclaims any and all warranties and liabilities of any kind, including without limitation, warranties of non-infringement of intellectual property rights of any third party.

Information

For further information on technology, delivery terms and conditions and prices, please contact the nearest Infineon Technologies Office (www.infineon.com).

Warnings

Due to technical requirements, components may contain dangerous substances. For information on the types in question, please contact the nearest Infineon Technologies Office.

Infineon Technologies components may be used in life-support devices or systems only with the express written approval of Infineon Technologies, if a failure of such components can reasonably be expected to cause the failure of that life-support device or system or to affect the safety or effectiveness of that device or system. Life support devices or systems are intended to be implanted in the human body or to support and/or maintain and sustain and/or protect human life. If they fail, it is reasonable to assume that the health of the user or other persons may be endangered.

Table of Contents

	Table of Contents	3
1	Summary of Features	5
1.1	Device Types / Ordering Information	6
1.2	Abbreviations	7
2	General Device Information	9
2.1	Pin Configuration	9
2.2	Pin Definitions and Functions	10
3	Functional Description	14
3.1	Power Management Unit (PMU)	19
3.1.1	Voltage Regulator 5.0V (VDDP)	22
3.1.2	Voltage Regulator 1.5V (VDDC)	23
3.1.3	External Voltage Regulator 5.0V (VDDEXT)	24
3.2	System Control Unit	25
3.2.1	System Control Unit - Power Modules	25
3.2.2	System Control Unit - Digital Part	26
3.3	XC800 Core	26
3.4	Memory Architecture	28
3.5	Flash Memory	29
3.6	Watchdog Timer 1 (WDT1)	29
3.7	Watchdog Timer (WDT)	31
3.8	Interrupt System	32
3.9	Multiplication/Division Unit	38
3.10	Parallel Ports	38
3.11	Timer 0 and Timer 1	41
3.12	Timer 2 and Timer 21	42
3.13	Timer 3	43
3.14	Capture/Compare Unit 6 (CCU6)	44
3.15	UART	46
3.16	LIN Transceiver	47
3.17	High-Speed Synchronous Serial Interface	47
3.18	Measurement Unit	49
3.19	Measurement Core Module (incl. ADC2)	51
3.20	Analog Digital Converter (ADC1)	52
3.21	High Voltage Monitor Input	53
3.22	High Side Switches	54
3.23	Low Side Switches	55
3.24	PWM Generator	56
3.25	Debug System	57
4	Application Information	58
4.1	Electric Drive Application	58
4.2	Connection of N.C. Pins	59
4.3	Connection of ADCGND Pin	59
4.4	Connection of Exposed Pad	59
4.5	Voltage Regulators-Blocking Capacitors	59
4.6	Additional External Components	59
4.7	ESD Tests	60
5	Electrical Characteristics	61

Table of Contents

5.1	General Characteristics	61
5.1.1	Absolute Maximum Ratings	61
5.1.2	Functional Range	62
5.1.3	Current Consumption	63
5.1.4	Thermal Resistance	63
5.1.5	Timing Characteristics	64
5.2	Power Management Unit (PMU)	65
5.2.1	PMU I/O Supply Parameters VDDP	65
5.2.2	PMU Core Supply Parameters VDDC	66
5.2.3	VDDEXT Voltage Regulator 5.0V	67
5.3	System Clocks	68
5.3.1	Oscillators and PLL	68
5.3.2	External Clock Parameters XTAL1, XTAL2	69
5.4	Flash Parameters	70
5.5	Parallel Ports (GPIO)	71
5.5.1	Functional Range	71
5.5.2	DC Parameters	71
5.6	LIN Transceiver	74
5.6.1	Electrical Characteristics	74
5.7	High-Speed Synchronous Serial Interface	78
5.8	Measurement Unit	79
5.8.1	Analog Digital Converter 8-Bit	79
5.8.2	Measurement Unit (VBAT_SENSE - Supply Voltage Attenuator)	79
5.8.3	Measurement Functions Monitoring Input Voltage Attenuator	80
5.8.4	Temperature Sensor Module	81
5.9	ADC - 10-Bit	82
5.9.1	VAREF	82
5.9.1.1	Functional Range	82
5.9.1.2	Electrical Characteristics	82
5.9.2	Analog/Digital Converter Parameters	83
5.10	High-Voltage Monitor Input	85
5.11	High Side Switches	86
5.11.1	Functional Range	86
5.11.2	Electrical Characteristics	86
5.12	Low Side Switches	89
5.12.1	Functional Range	89
5.12.2	Electrical Characteristics	89
6	Package Outlines	91
7	Revision History	92

1 Summary of Features

- High performance XC800 core
 - compatible to standard 8051 core
 - up to 40 MHz clock frequency
 - two clocks per machine cycle architecture
 - two data pointers
- On-chip memory
 - 60 kByte + 4 kByte Flash for program code and data (4 kByte EEPROM emulation built-in)
 - 512 Byte One Time Programmable Memory (OTP)
 - 512 Byte 100 Time Programmable Memory (100TP)
 - 256 Byte RAM, 3 kByte XRAM
 - BootROM for startup firmware and Flash routines
- Core logic supply at 1.5 V
- On-chip OSC and PLL for clock generation
 - Loss of clock detection with fail safe mode for power switches
- Watchdog timer (WDT) with programmable window feature for refresh operation and warning prior to overflow
- General-purpose I/O Port (GPIO) with wake-up capability
- Multiplication/division unit (MDU) for arithmetic calculation
- Software libraries to support floating point and MDU calculations
- Five 16-Bit timers - Timer 0, Timer 1, Timer 2, Timer 21 and Timer 3
- Capture/compare unit for PWM signal generation (CCU6) with Timer 12 and Timer 13
- Full duplex serial interface (UART) with LIN support
- Synchronous serial channel (SSC)
- On-chip debug support via 2-wire Device Access Port (DAP)
- LIN Bootstrap loader (LIN BSL)
- LIN transceiver compliant to LIN 1.3, LIN 2.0 and LIN 2.1
- 2 x Low Side Switches with clamping capability incl. PWM functionality, e.g. as relay driver
- 2 x High Side Switches with cyclic sense option and PWM functionality, e.g. for LED or powering of switches
- 5 x High Voltage Monitor Input pins for wake-up and with cyclic sense and analog measurement option
- Measurement unit with 10 channels, 8-Bit A/D Converter (ADC2) and data post processing
- 8 channels, 10-Bit A/D Converter (including battery voltage and supply voltage measurement) (ADC1)
- Single power supply from 3.0 V to 27 V
- Low-dropout voltage regulators (LDO)
- Dedicated 5 V voltage regulator for external loads (e.g. hall sensor)
- Programmable window watchdog (WDT1) with independent on-chip clock source
- Power saving modes
 - MCU slow-down mode
 - Stop Mode
 - Sleep Mode
 - Cyclic wake-up and cyclic sense during Stop Mode and Sleep Mode
- Power-on and undervoltage/brownout reset generator
- Overtemperature protection
- Overcurrent protection with shutdown
- Supported by a full range of development tools including C compilers, macro assembler packages, emulators, evaluation boards, HLL debugger, programming tools, software packages
- Temperature Range T_j : -40 °C up to 150 °C
- Package VQFN-48-29
- Green package (RoHS compliant)

1.1 Device Types / Ordering Information

The TLE983x product family features devices with different peripheral modules, configurations and program memory sizes to offer cost-effective solutions for different application requirements. [Table 1](#) describes the TLE9834QX device configuration.

Table 1 Device Configuration

Device Name	Max Clock Frequency	High Side Switches	High Voltage Monitor Inputs	Flash Size	Bidirectional Parallel Port I/O's	Operational Amplifier
TLE9834QX	40 MHz	2	5	64 kByte	11	no

1.2 Abbreviations

The following acronyms and terms are used within this document. List see in [Table 2](#).

Table 2 Acronyms

Acronyms	Name
ALU	Arithmetic Logic Unit
CCU6	Capture Compare Unit 6
CGU	Clock Generation Unit
CMU	Cyclic Management Unit
DAP	Device Access Port
DPP	Data Post Processing
ECC	Error Correction Code
EEPROM	Electrically Erasable Programmable Read Only Memory
GPIO	General Purpose Input Output
FSR	Full Scale Range
ICU	Interrupt Control Unit
IRAM	Internal Random Access Memory - Internal Data Memory
LDO	Low DropOut voltage regulator
LIN	Local Interconnect Network
LSB	Least Significant Bit
MCU	Micro Controller Unit
MDU	Multiplication Division Unit
MMC	Monitor Mode Control
MSB	Most Significant Bit
NMI	Non Maskable Interrupt
OCDS	On Chip Debug Support
OTP	One Time Programmable
OSC	Oscillator
PC	Program Counter
PCU	Power Control Unit
PD	Pull Down
PGU	Power supply Generation Unit
PLL	Phase Locked Loop
PMU	Power Management Unit
PSW	Program Status Word
PU	Pull Up
PWM	Pulse Width Modulation
RAM	Random Access Memory
RCU	Reset Control Unit
RMU	Reset Management Unit

Table 2 Acronyms

Acronyms	Name
ROM	Read Only Memory
SCK	SSC Clock
SFR	Special Function Register
SOW	Short Open Window (for WDT1)
SPI	Serial Peripheral Interface
SSC	Synchronous Serial Channel
SSU	System Status Unit
TMS	Test Mode Select
UART	Universal Asynchronous Receiver Transmitter
UDIG	Universal Digital Controller for ADC1
VBG	Voltage reference Band Gap
WDT	Watchdog timer
WMU	Wake-up Management Unit
XRAM	On-Chip eXternal Data Memory
XSFR	On-Chip eXternal Special Function Register

2 General Device Information

2.1 Pin Configuration

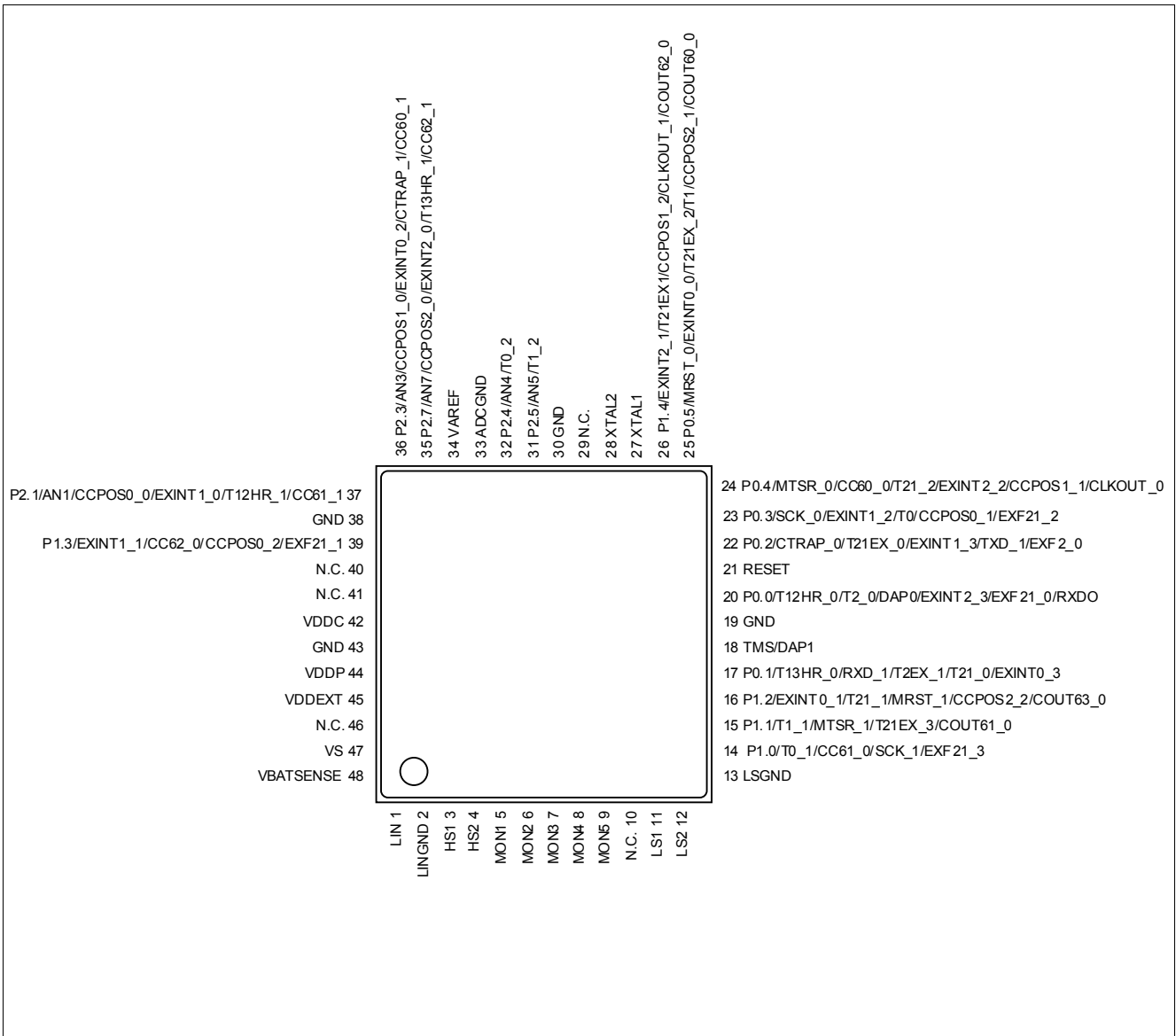

Figure 1 TLE9834QX pin configuration, VQFN-48-29 package (top view)

2.2 Pin Definitions and Functions

After reset, all pins are configured as input (except supply and LIN pins) with one of the following settings:

- Pull-up device enabled only (PU)
- Pull-down device enabled only (PD)
- Input with both pull-up and pull-down devices disabled (I)
- Output with output stage deactivated = high impedance state (Hi-Z)

The functions and default states of the TLE9834QX external pins are provided in the following table.

Type: indicates the pin type.

- I/O: Input or output
- I: Input only
- O: Output only
- P: Power supply

Table 3 Pin Definitions and Functions

Symbol	Pin Number	Type	Reset State	Function
P0				Port 0 Port 0 is an 6-Bit bidirectional general purpose I/O port. Alternate functions can be assigned as follows: DAP, CCU6, Timer 0, Timer 1, Timer 2, Timer 21, UART, SSC, external interrupt input and clock output.
P0.0	20	I/O	I/PU	T12HR_0 CCU6 Timer 12 hardware run input T2_0 Timer 2 input DAP0 Debug Access Port 0 EXINT2_3 External interrupt input 0 EXF21_0 Timer 21 external flag output RXDO UART transmit data output (synchronous mode)
P0.1	17	I/O	I/PU	T13HR_0 CCU6 Timer 13 hardware run input RXD_1 UART receive input T2EX_1 Timer 2 external trigger input T21_0 Timer 21 input EXINT0_3 External interrupt input 0
P0.2	22	I/O	I/PU	CTRAP_0 CCU6 trap input T21EX_0 Timer 21 external trigger input EXINT1_3 External interrupt input 1 TXD_1 UART transmit output EXF2_0 Timer 2 external flag output
P0.3	23	I/O	I/PU	SCK_0 SSC clock input (for slave) / output (for master) EXINT1_2 External interrupt input 1 T0 Timer 0 input CCPOS0_1 CCU6 hall input 0 EXF21_2 Timer 21 external flag output
P0.4	24	I/O	I/PU	MTSR_0 SSC master transmit output / slave receive input CC60_0 CCU6 capture/compare channel 0 input/output T21_2 Timer 21 input EXINT2_2 External interrupt input 2 CCPOS1_1 CCU6 hall input 1 CLKOUT_0 Clock output

Table 3 Pin Definitions and Functions (cont'd)

Symbol	Pin Number	Type	Reset State	Function
P0.5	25	I/O	I/PU	MRST_0 SSC master receive input / slave transmit output EXINT0_0 External interrupt input 0 T21EX_2 Timer 21 external trigger input T1 Timer 1 input CCPOS2_1 CCU6 hall input 2 COUT60_0 CCU6 capture/compare channel 0 output
P1				Port 1 Port 1 is an 5-Bit bidirectional general purpose I/O port. Alternate functions can be assigned as follows: CCU6, Timer 0, Timer 1 Timer 21, SSC, external interrupt input and clock output.
P1.0	14	I/O	I	T0_1 Timer 0 input CC61_0 CCU6 capture/compare channel 1 input/output SCK_1 SSC clock input (for slave) / output (for master) EXF21_3 Timer 21 external flag output
P1.1	15	I/O	I	T1_1 Timer 1 input MTRSR_1 SSC master transmit output/slave receive input T21EX_3 Timer 21 external trigger input COUT61_0 CCU6 capture/compare channel 1 output
P1.2	16	I/O	I	EXINT0_1 External interrupt input 0 T21_1 Timer 21 input MRST_1 SSC master receive input/slave transmit output CCPOS2_2 CCU6 hall input 2 COUT63_0 CCU6 capture/compare channel 3 output
P1.3	39	I/O	I	EXINT1_1 External interrupt input 1 CC62_0 CCU6 capture/compare channel 2 input/output CCPOS0_2 CCU6 hall input 0 EXF21_1 Timer 21 external flag output
P1.4	26	I/O	I	EXINT2_1 External interrupt input 2 T21EX_1 Timer 21 external trigger input CCPOS1_2 CCU6 hall input 1 CLKOUT_1 Clock output COUT62_0 CCU6 capture/compare channel 2 output
P2				Port 2 Port 2 is an 5-Bit general purpose input-only port. Alternate functions can be assigned as follows: CCU6, Timer 0, Timer 1, Timer 21 and external interrupt input It is also used as analog inputs for the 10-Bit ADC (ADC1).
P2.1	37	I	I	AN1 ADC1 analog input channel 1 CCPOS0_0 CCU6 hall input 0 EXINT1_0 External interrupt input 1 T12HR_1 CCU6 Timer 12 hardware run input CC61_1 CCU6 capture/compare channel 1 input

Table 3 Pin Definitions and Functions (cont'd)

Symbol	Pin Number	Type	Reset State	Function
P2.3	36	I	I	AN3 ADC1 analog input channel 3 CCPOS1_0 CCU6 hall input 1 EXINT0_2 External interrupt input 0 CTRAP_1 CCU6 trap input CC60_1 CCU6 capture/compare channel 0 input
P2.4	32	I	I	AN4 ADC1 analog input channel 4 T0_2 Timer 0 input
P2.5	31	I	I	AN5 ADC1 analog input channel 5 T1_2 Timer 1 input
P2.7	35	I	I	AN7 ADC1 analog input channel 7 CCPOS2_0 CCU6 hall input 2 EXINT2_0 External interrupt input 2 T13HR_1 CCU6 timer 13 hardware run input CC62_1 CCU6 capture/compare channel 2 input
Power Supply				
VS	47	P	–	Battery supply input
VDDP	44	P	–	I/O port supply (5.0 V). Do not connect external loads. For buffer and bypass capacitors.
VDDC	42	P	–	Core supply (1.5 V during Active Mode, 0.9 V during Stop Mode). Do not connect external loads. For buffer/bypass capacitor.
VDDEXT	45	P	–	External voltage supply output (5.0 V, 20 mA)
LSGND	13	P	–	Low Side ground LS1, LS2
GND	30, 43, 19, 38	P	–	Core supply ground; analog supply ground
ADCGND	33	P	–	Analog supply ground for ADC1
LINGND	2	P	–	LIN ground
Monitor Inputs				
MON1	5	I	I	High Voltage Monitor Input 1
MON2	6	I	I	High Voltage Monitor Input 2
MON3	7	I	I	High Voltage Monitor Input 3
MON4	8	I	I	High Voltage Monitor Input 4
MON5	9	I	I	High Voltage Monitor Input 5
High Side Switch / Low Side Switch Outputs				
LS1	11	O	Hi-Z	Low Side Switch output 1
LS2	12	O	Hi-Z	Low Side Switch output 2
HS1	3	O	Hi-Z	High Side Switch output 1
HS2	4	O	Hi-Z	High Side Switch output 2
LIN Interface				
LIN	1	I/O	PU	LIN bus interface input/output

Table 3 Pin Definitions and Functions (cont'd)

Symbol	Pin Number	Type	Reset State	Function
Others				
VAREF	34	I/O	O	5V ADC1 reference voltage
XTAL1	27	I	I	External oscillator input
XTAL2	28	O	Hi-Z	External oscillator output
TMS	18	I	I/PD	TMS test mode select input DAP1 Debug Access Port 1
RESET	21	I/O	I/O/PU	Reset input, not available during Sleep Mode
VBAT_SENSE	48	I	I	Battery supply voltage sense input
N.C.	10, 29, 40, 41, 46	–	–	Not connected - can be connected to GND

3 Functional Description

This highly integrated circuit contains analog and digital functional blocks. For system and interface control an embedded 8-Bit state-of-the-art microcontroller, compatible to the standard 8051 core with On-Chip Debug Support (OCDS), is available. For internal and external power supply purposes, on-chip low drop-out regulators are existent. An internal oscillator provides a cost effective and suitable clock in particular for LIN slave nodes. As communication interface, a LIN transceiver and several High Voltage Monitor Inputs with adjustable threshold and filters are available. Furthermore two High Side Switches (e.g. for driving LEDs or cyclic powering of switches), two Low Side Switches (e.g. for relays) and several general purpose input/outputs (GPIO) with pulse-width modulation (PWM) capabilities are available.

The Micro Controller Unit (MCU) supervision and system protection including reset feature is controlled by a programmable window watchdog. A cyclic wake-up circuit, supply voltage supervision and integrated temperature sensors are available on-chip.

All relevant modules offer power saving modes in order to support terminal 30 connected automotive applications. A wake-up from the power saving mode is possible via a LIN bus message, via the monitoring inputs, via the GPIO ports or repetitive with a programmable time period (cyclic wake-up).

The integrated circuit is available in a VQFN-48-29 package with 0.5 mm pitch and is designed to withstand the severe conditions of automotive applications.

Block Diagram

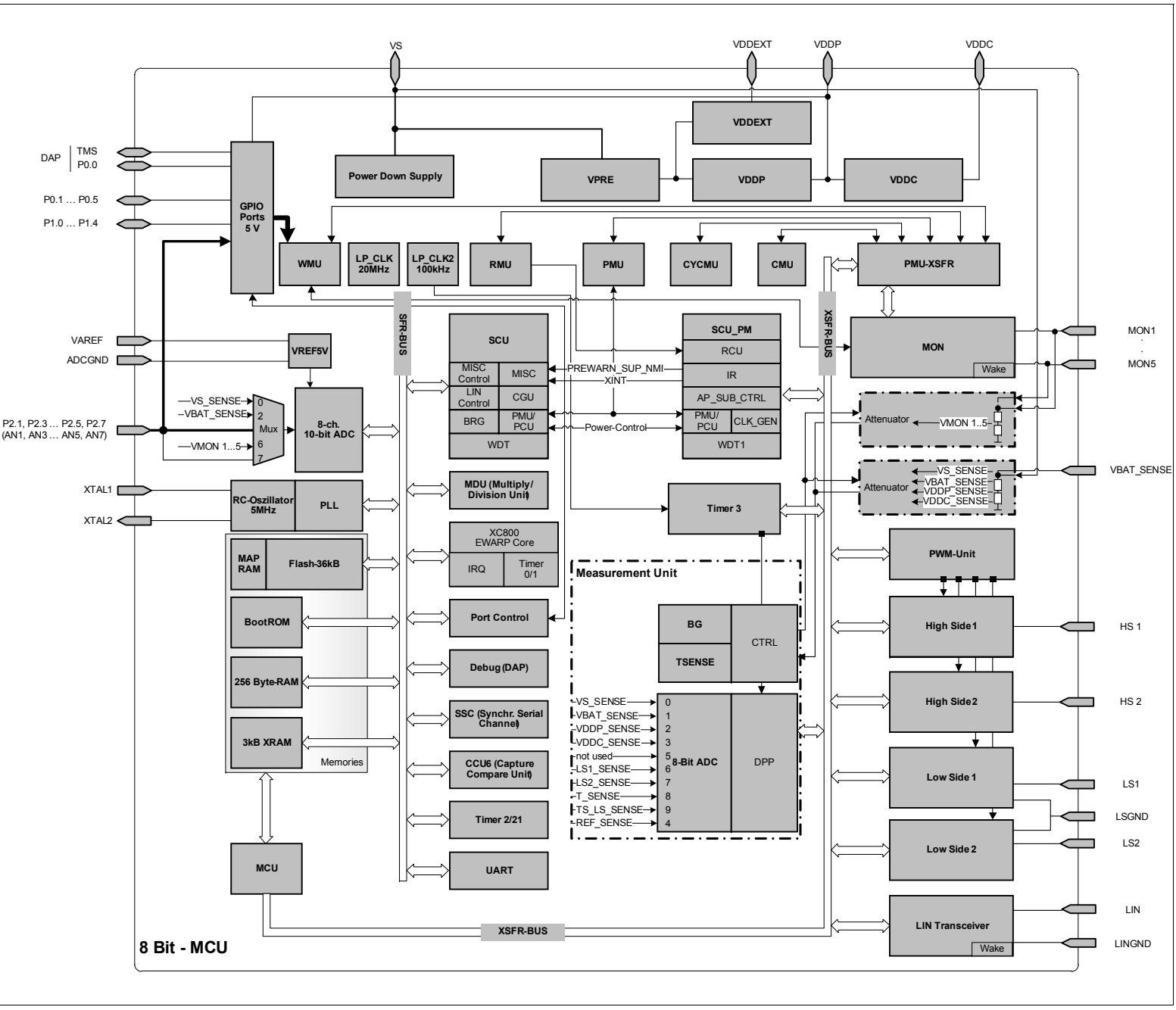

Figure 2 Block Diagram

The TLE9834QX has several operational modes mainly to support low power consumption requirements. The low power modes and state transitions are depicted in Figure 3 below.

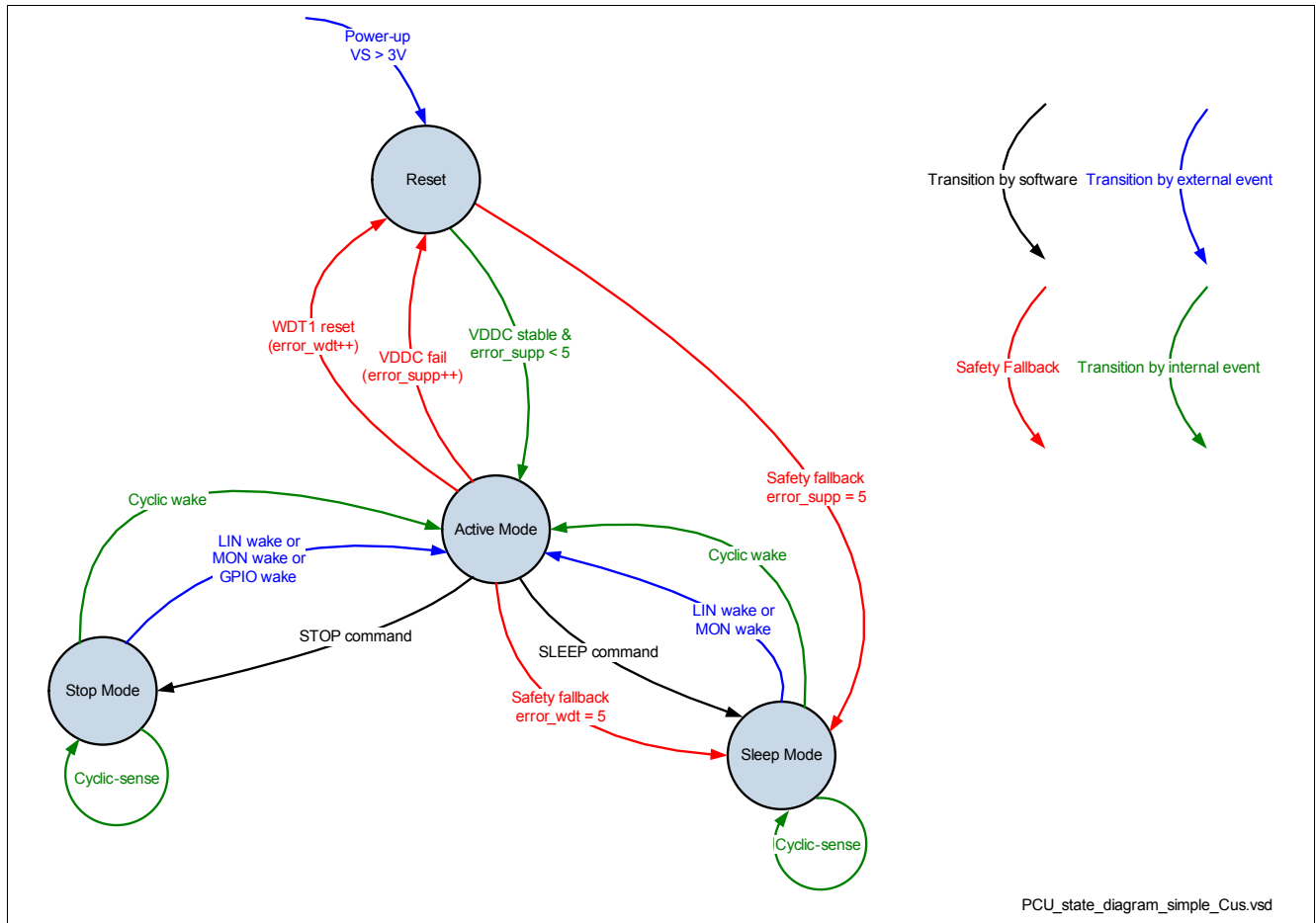

Figure 3 Power Control State Diagram

Reset Mode

The Reset Mode is a transition mode e.g. during power-up of the device after a power-on reset. In this mode the on-chip power supplies are enabled and all other modules are initialized. Once the core supply VDDC is stable, the Active Mode is entered. In case the watchdog timer WDT1 fails for more than four times, a fail-safe transition to the Sleep Mode is done.

Active Mode

In Active Mode all modules are activated and the TLE9834QX is fully operational.

Stop Mode

The Stop Mode is one out of two low power modes. The transition to the low power modes is done by setting the respective Bits in the mode control register. In Stop Mode the embedded microcontroller is still powered allowing faster wake-up reaction times. A wake-up from this mode is possible by LIN bus activity, the High Voltage Monitor Input pins or the respective 5V GPIOs.

Sleep Mode

The Sleep Mode is the second low-power mode. The transition to the low-power modes is done by setting the respective Bits in the MCU mode control register. In Sleep Mode the embedded microcontroller power supply is deactivated allowing the lowest system power consumption, but the wake-up time is longer compared to the Stop Mode. A wake-up from this mode is possible by LIN bus activity or the High Voltage Monitor Input pins. A wake-up from Sleep Mode behaves similar to a power-on reset.

Cyclic Wake-up Mode

The cyclic wake-up mode is a special operating mode of the Sleep Mode and the Stop Mode. The transition to the cyclic wake-up mode is done by first setting the respective Bits in the mode control register followed by the SLEEP or STOP command. Additional to the cyclic wake-up behavior (wake-up after a programmable time period), the wake-up sources of the normal Stop Mode and Sleep Mode are available.

Cyclic Sense Mode

The cyclic sense mode is a special operating mode of the Sleep Mode and the Stop Mode. The transition to the cyclic sense mode is done by first setting the respective Bits in the mode control register followed by the STOP or SLEEP command. In cyclic sense mode a High Side Switch can be switched on periodically for biasing some switches for example. The wake-up condition is configurable, when the sense result of defined monitor inputs at a window of interest changed compared to the previous wake-up period or reached a defined state respectively. In this case the Active Mode is entered immediately. For cyclic sense in Stop Mode VDDEXT can be switched on periodically. Furthermore cyclic sense allows to sense dedicated GPIO port states and transitions when in Stop Mode.

The following table shows the possible power mode configurations of each major module or function respectively.

Table 4 Power mode configurations

Module/function	Active Mode	Stop Mode	Sleep Mode	Comment
VDD1V5PD	ON	ON	ON	Power Down Supply
VPRE, VDDP, VDDC	ON	ON (no dynamic load)	OFF	–
VDDEXT	ON/OFF	ON (no dynamic load)/OFF cyclic ON/OFF	OFF	–
HSx	ON/OFF	cyclic ON/OFF	cyclic ON/OFF	cyclic sense
LSx	ON/OFF	OFF	OFF	–
PWM GEN.	ON/OFF	OFF	OFF	–
LIN TRx	ON/OFF	wake-up only/ OFF	wake-up only/ OFF	–
MON1 - MON5 (wake-up)	n.a.	disabled/static/cyclic	disabled/static/ cyclic	cyclic: combined with HS=on
MON1 - MON5 (measurement)	ON/OFF	OFF	OFF	available on four channels
VS sense	ON/OFF brownout detection	brownout detection	brownout detection	brownout detection done in PCU
VBAT_SENSE	ON/OFF	OFF	OFF	–
GPIO 5V (wake-up)	n.a.	disabled/static/cyclic	OFF	–
GPIO 5V (active)	ON	ON	OFF	–
WDT1	ON	OFF	OFF	–

Table 4 Power mode configurations

Module/function	Active Mode	Stop Mode	Sleep Mode	Comment
CYCLIC Modes	n.a.	cyclic wake-up/ cyclic sense/OFF	cyclic wake-up/ cyclic sense/OFF	cyclic sense with HS, VDDEXT; wake-up from cyclic wake needs MC for entering Sleep Mode / Stop Mode again
Measurement Unit	ON ¹⁾	OFF	OFF	–
MCU	ON/slow- down/HALT	STOP ²⁾	OFF	–
CLOCK GEN (MC)	ON	OFF	OFF	–
LP_CLK (20 MHz)	ON	OFF	OFF	WDT1
LP_CLK2 (100 kHz)	ON	ON	ON	for cyclic wake-up

1) Cannot not be switched off due to safety reasons

2) MC PLL clock disabled, MC supply reduced to 0.9 V

Wake-up Source Prioritization

All wake-up sources have the same priority. In order to handle the asynchronous nature of the wake-up sources, the first wake-up signal will initiate the wake-up sequence. Nevertheless all wake-up sources are latched in order to provide all wake-up events to the application software. The software can clear the wake-up source flags. It is ensured, that no wake-up event is lost.

As default wake-up sources, the LIN and MON inputs are activated after power-on reset only. GPIO ports as wake-up sources are disabled by default after power-on reset. The application software can reconfigure the wake-up sources according to the application needs.

Wake-up Levels and Transitions

The wake-up can be triggered by rising, falling or both signal edges for each monitor and GPIO input individually.

3.1 Power Management Unit (PMU)

The purpose of the power management unit is to ensure the fail safe behavior of embedded automotive systems. Therefore the power management unit controls all system modes including the corresponding transitions. The power management unit is responsible for generating all required voltage supplies for the embedded MCU (VDDC, VDDP) and the external sensor supply (VDDEXT). Additionally, the PMU provides well defined sequences for the system mode transitions and generates hierarchical reset priorities. The reset priorities control the reset behavior of all system functionalities, especially the reset behavior of the embedded MCU, including the test hardware. All these functions are controlled by finite state machines. The system master functionality of the PMU forces the generation of an independent logic supply (Power Down Supply) and system clock (LP_CLK). Therefore the PMU needs a module internal logic supply and system clock which works independently of the MCU clock.

The following state diagram shows the available modes of the device.

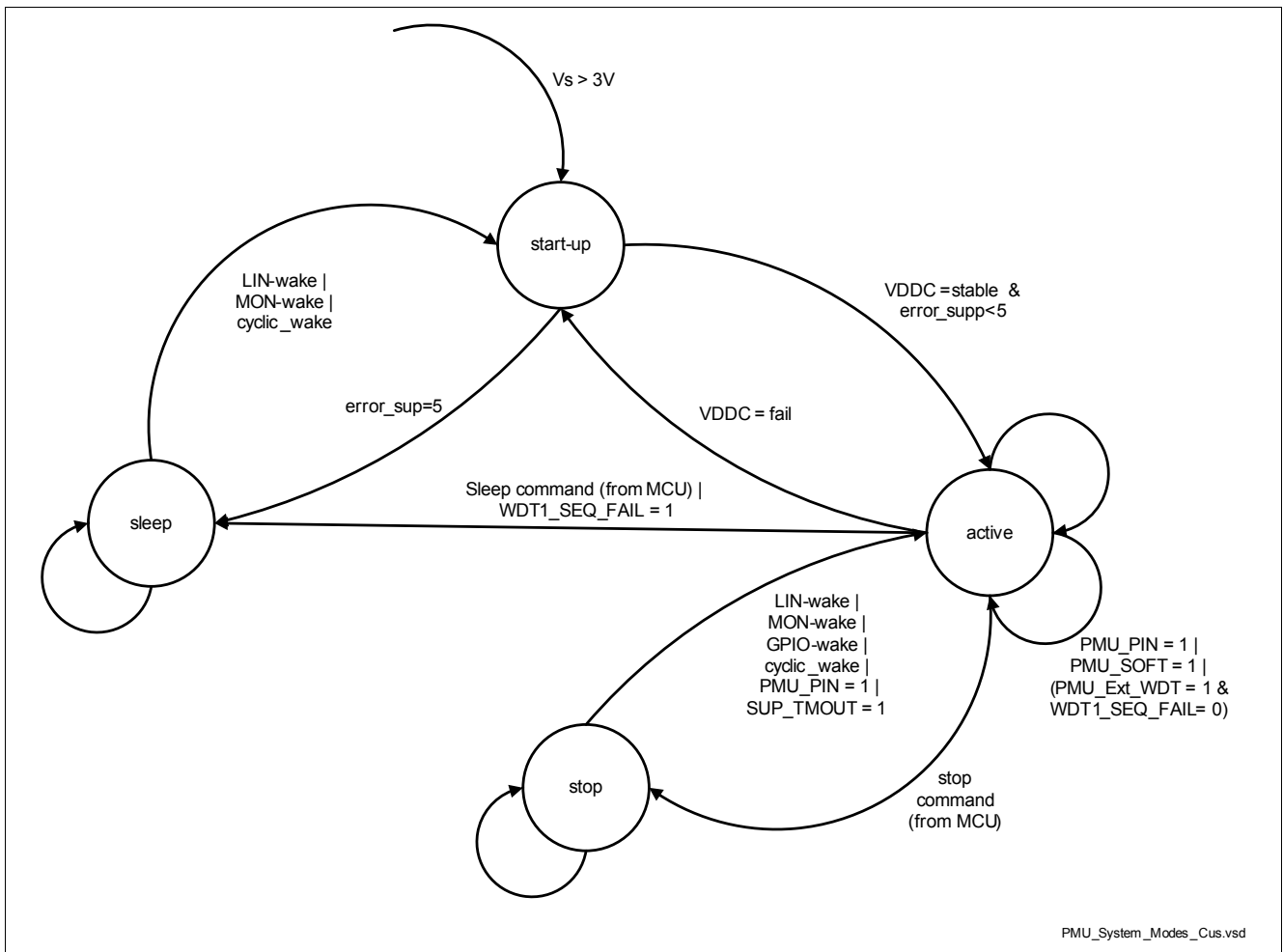

Figure 4 Power Management Unit System Modes

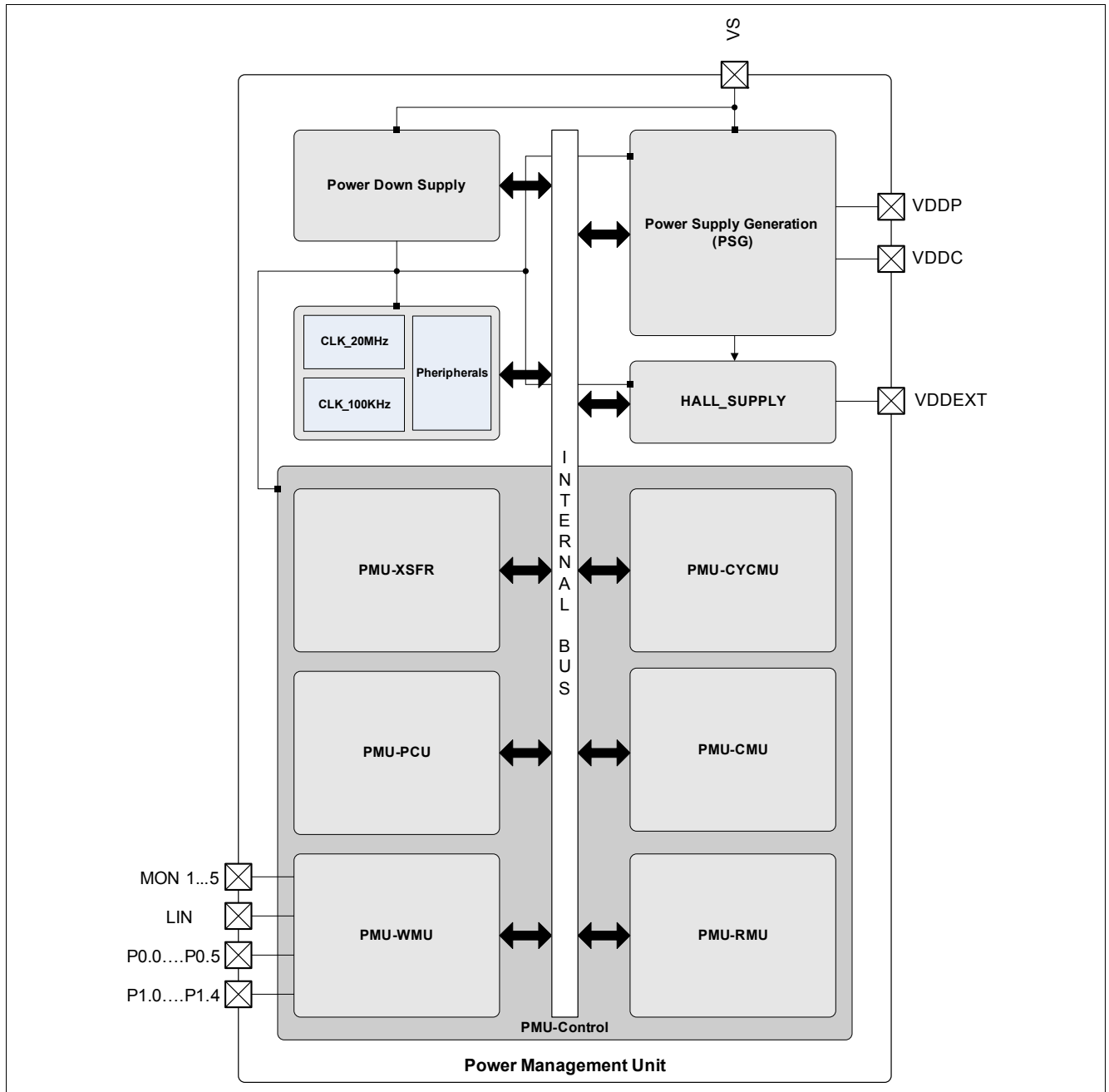

Figure 5 Power Management Unit Block Diagram

Table 5 Description of PMU Submodules

Mod. Name	Modules	Functions
Power Down Supply	Independent Supply Voltage Generation for PMU	This supply is only dedicated to the PMU to ensure a independent operation of generated power supplies (VDDP, VDDC).
LP_CLK (= 20 MHz)	- Clock Source for all PMU submodules - Backup Clock Source for System - Clock Source for WDT1	This ultra low power oscillator generates the clock for the PMU. This clock is also used as backup clock for the system in case of PLL clock failure and as independent clock source for WDT1
LP_CLK2 (= 100 kHz)	Clock Source for PMU	This ultra low power oscillator generates the clock for the PMU mainly in Stop Mode and in the cyclic modes.
Peripherals	Peripheral blocks of PMU	This blocks includes all relevant peripherals to ensure a stable and fail safe PMU startup and operation
Power Supply Generation Unit (PGU)	Voltage regulators for VDDP and VDDC	This block includes the voltage regulators for the pad supply (VDDP) and the core supply (VDDC) including all diagnosis and safety features
VDDEXT (Hall Sensor Supply)	Voltage regulator for VDDEXT to supply external modules (e.g. Hall Sensors)	This voltage regulator is a dedicated supply for external modules and can also be used for cyclic sense operations (e.g. with hall sensor)
PMU-XSFR	All PMU relevant Extended Special Function Registers	This module contains all PMU relevant registers, which are needed to control and monitor the PMU.
PMU-PCU	Power Control Unit of the PMU	This block is responsible for controlling all power related actions within the PGU Module.
PMU-WMU	Wake-up Management Unit of the PMU	This block is responsible for controlling all wake-up related actions within the PMU Module.
PMU-CYCMU	Cyclic Management Unit of the PMU	This block is responsible for controlling all actions within cyclic mode.
PMU-CMU	Clock Management Unit of the PMU	This block is responsible for controlling all clocking actions within the PMU.
PMU-RMU	Reset Management Unit of the PMU	This block is responsible for generating all system required resets.

3.1.1 Voltage Regulator 5.0V (VDDP)

This module represents the 5 V voltage regulator, which serves as pad supply for the parallel port pins and other 5 V analog functions.

Features

- 5 V low-drop voltage regulator
- Current limitation
- Overcurrent monitoring and shutdown with MCU signalling (Interrupt)
- Overvoltage monitoring with MCU signalling (Interrupt)
- Undervoltage monitoring with MCU signalling (Interrupt)
- Preregulator for VDDC regulator
- GPIO supply
- Pull-down current source at the output for Sleep Mode (100 μ A)

The output capacitor C_{VDDP} is mandatory to ensure a proper regulator functionality.

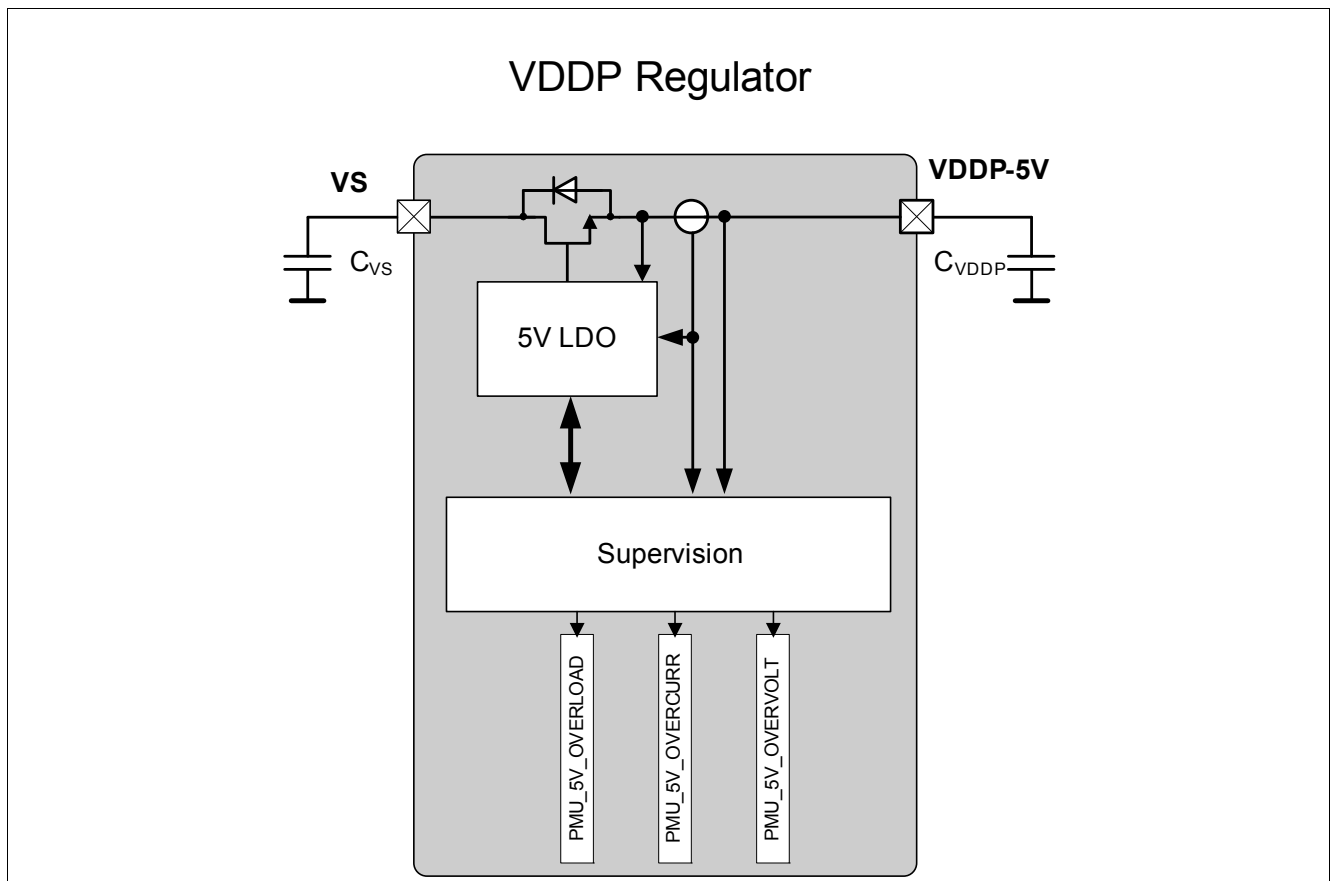

Figure 6 Module Block Diagram of VDDP Voltage Regulator

3.1.2 Voltage Regulator 1.5V (VDDC)

This module represents the 1.5 V voltage regulator, which serves as core supply for the 8-bit μ C and other chip internal analog 1.5 V functions (e.g. 8 Bit ADC). To further reduce the current consumption of the 8-bit MCU during Stop Mode the output voltage is optionally reduced to 0.9 V.

Features

- 1.5 V low-drop voltage regulator
- Optional 0.9 V in Stop Mode
- Current limitation
- Overcurrent monitoring and shutdown with MCU signalling (interrupt)
- Overvoltage monitoring with MCU signalling (interrupt)
- Undervoltage monitoring with MCU signalling (interrupt)
- Pull-down current source at the output for Sleep Mode (100 μ A)

The output capacitor C_{VDDC} is mandatory to ensure a proper regulator functionality.

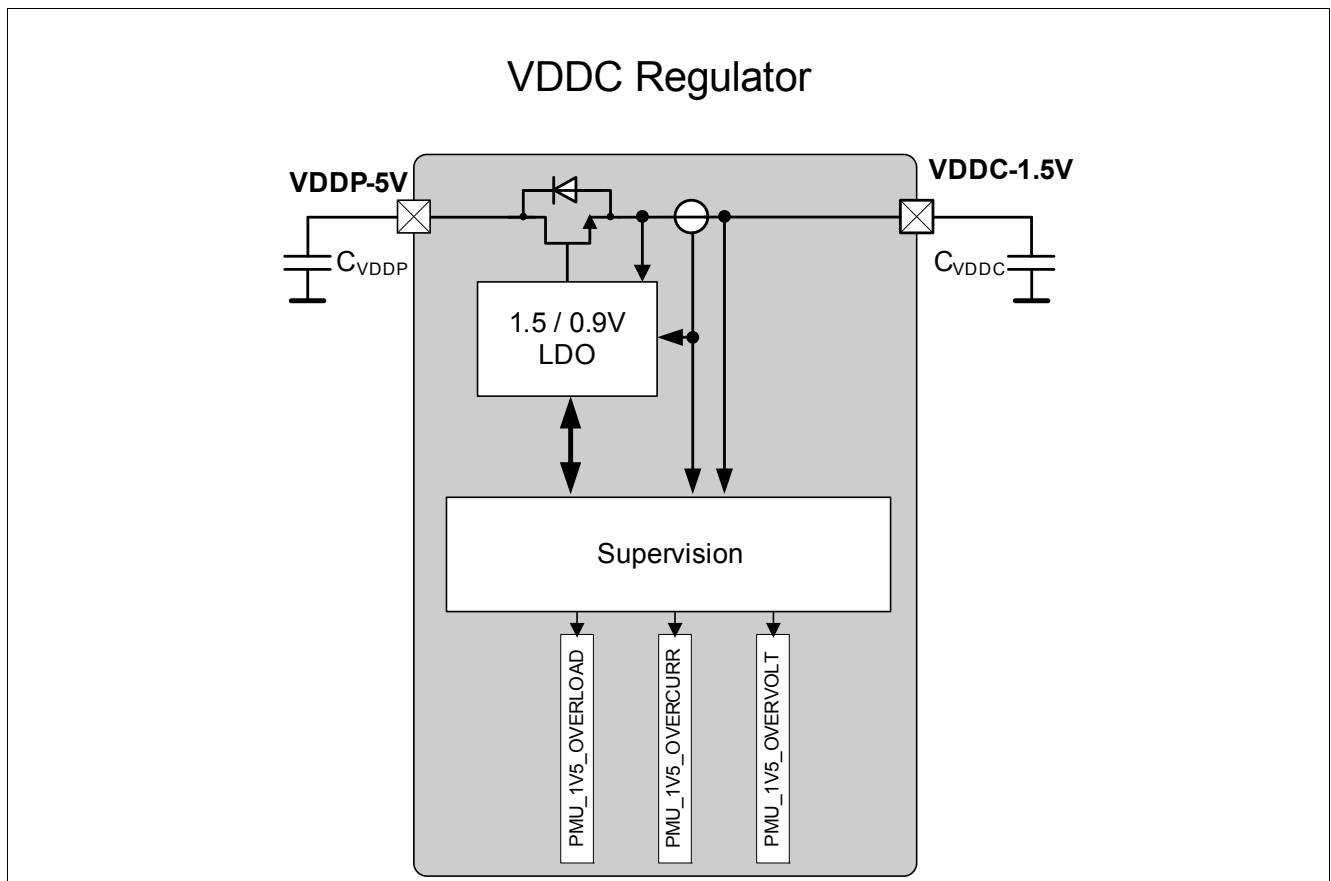

Figure 7 Module Block Diagram of VDDC Voltage Regulator

3.1.3 External Voltage Regulator 5.0V (VDDEXT)

The external voltage regulator provides 5 V output voltage in order to supply external circuitry like LEDs, hall sensors or potentiometers.

Features

- Switchable +5 V, 20 mA low-drop voltage regulator
- Switch-on overcurrent blanking time in order to drive small capacitive loads
- Short circuit robust
- Overvoltage monitoring with MCU interrupt signalling
- Undervoltage monitoring with MCU interrupt signalling
- Selectable switch-on slew-rate 0.95 V/μs max. @10 mA supply current, 10 nF capacitive load
- Pull-down current source at the output for Sleep Mode and off mode (100 μA)
- Cyclic sense option together with GPIOs

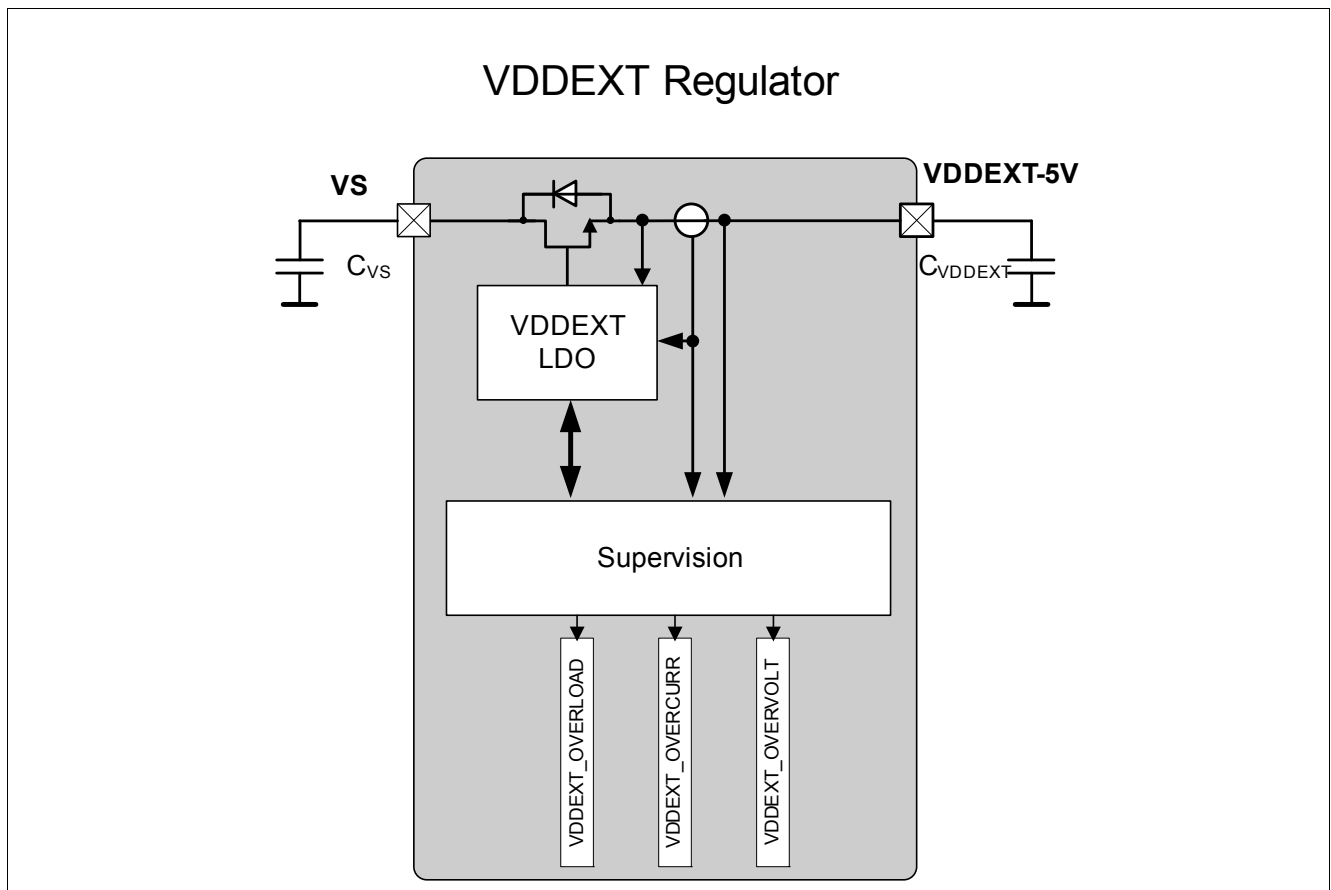

Figure 8 Module Block Diagram

3.2 System Control Unit

3.2.1 System Control Unit - Power Modules

The System Control Unit of the power modules consists of the following sub-modules:

- Reset Control Unit (RCU): generation of all required subsystem resets
- Clock Generation Unit (CGU): providing all required clocks to the analog subsystem
- Interrupt Control Unit (ICU): all system relevant interrupt flags and status flags
- Power Control Unit (PCU): takes over control when device enters and exits Sleep Mode and Stop Mode
- System Status Unit (SSU): controls mode changes due to system failures
- External Watchdog (WDT1): independent system watchdog to monitor system activity

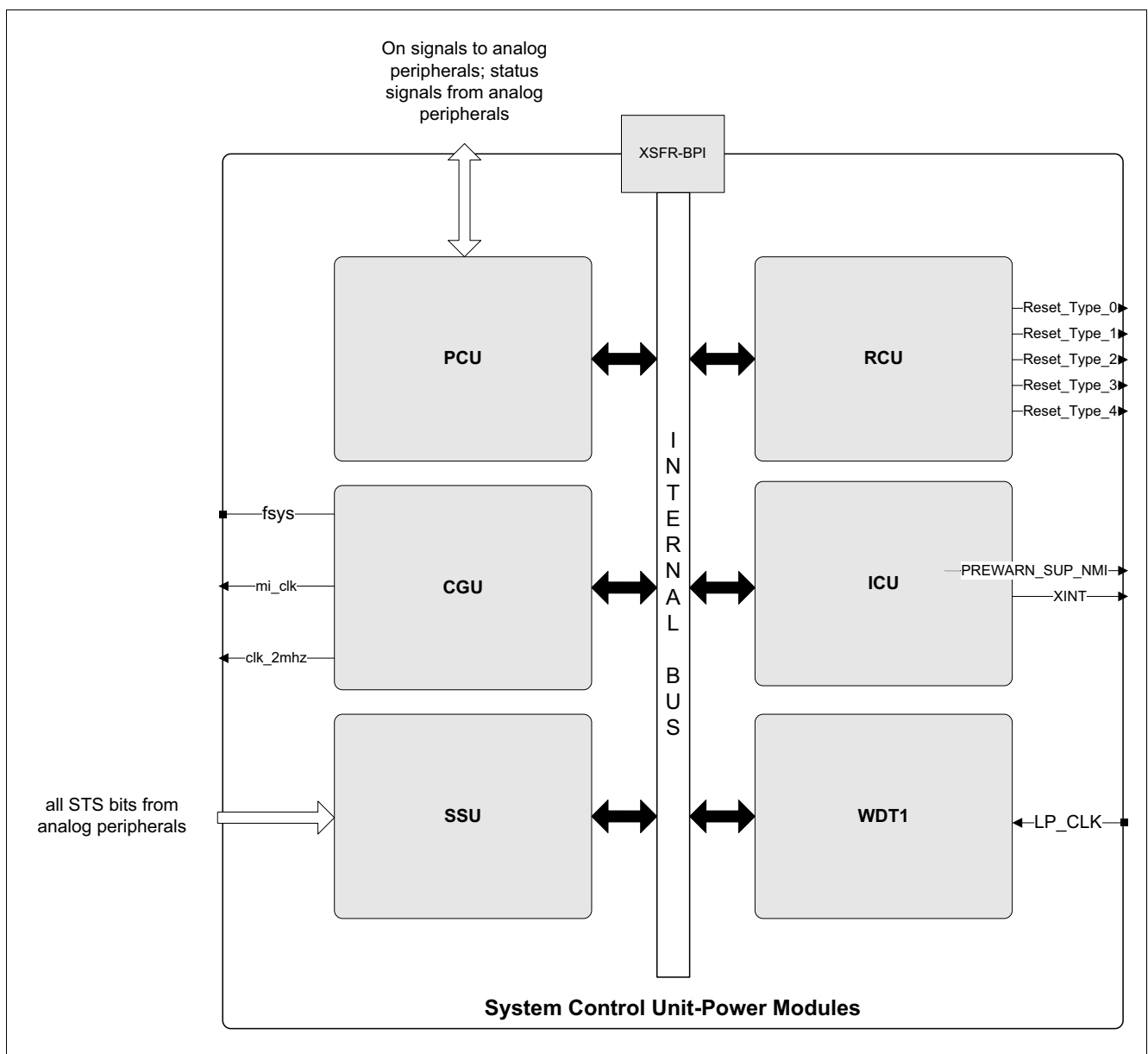

Figure 9 Block Diagram of System Control Unit - Power Modules