



Chipsmall Limited consists of a professional team with an average of over 10 year of expertise in the distribution of electronic components. Based in Hongkong, we have already established firm and mutual-benefit business relationships with customers from,Europe,America and south Asia,supplying obsolete and hard-to-find components to meet their specific needs.

With the principle of “Quality Parts,Customers Priority,Honest Operation,and Considerate Service”,our business mainly focus on the distribution of electronic components. Line cards we deal with include Microchip,ALPS,ROHM,Xilinx,Pulse,ON,Everlight and Freescale. Main products comprise IC,Modules,Potentiometer,IC Socket,Relay,Connector.Our parts cover such applications as commercial,industrial, and automotives areas.

We are looking forward to setting up business relationship with you and hope to provide you with the best service and solution. Let us make a better world for our industry!



Contact us

Tel: +86-755-8981 8866 Fax: +86-755-8427 6832

Email & Skype: info@chipsmall.com Web: www.chipsmall.com

Address: A1208, Overseas Decoration Building, #122 Zhenhua RD., Futian, Shenzhen, China





Application Specific Discretes
A.S.D.TM

TLPxxM/G/G-1

TRIPOLAR OVERVOLTAGE PROTECTION for TELECOM LINE

MAIN APPLICATIONS

Any sensitive telecom equipment requiring protection against lightning :

- Analog and ISDN line cards
- Main Distribution Frames
- Terminal and transmission equipment
- Gas-tube replacement

DESCRIPTION

The TLPxxM/G/G-1 series are tripolar transient surge arrestors used for primary and secondary protection in sensitive telecom equipment.

FEATURES

- TRIPOLAR CROWBAR PROTECTION
- VOLTAGE RANGE SELECTED FOR TELECOM APPLICATIONS
- REPETITIVE PEAK PULSE CURRENT :
 $I_{PP} = 100 \text{ A (10 / 1000 } \mu\text{s)}$
- HOLDING CURRENT : $I_H = 150 \text{ mA}$
- LOW CAPACITANCE : $C = 110 \text{ pF typ.}$
- LOW LEAKAGE CURRENT : $I_R = 5 \mu\text{A max}$

BENEFITS

- No ageing and no noise.
- If destroyed, the TLPxxM/G/G-1 falls into short circuit, still ensuring protection.
- Access to Surface Mount applications thanks to the PowerSO-10TM and D²PAK package.

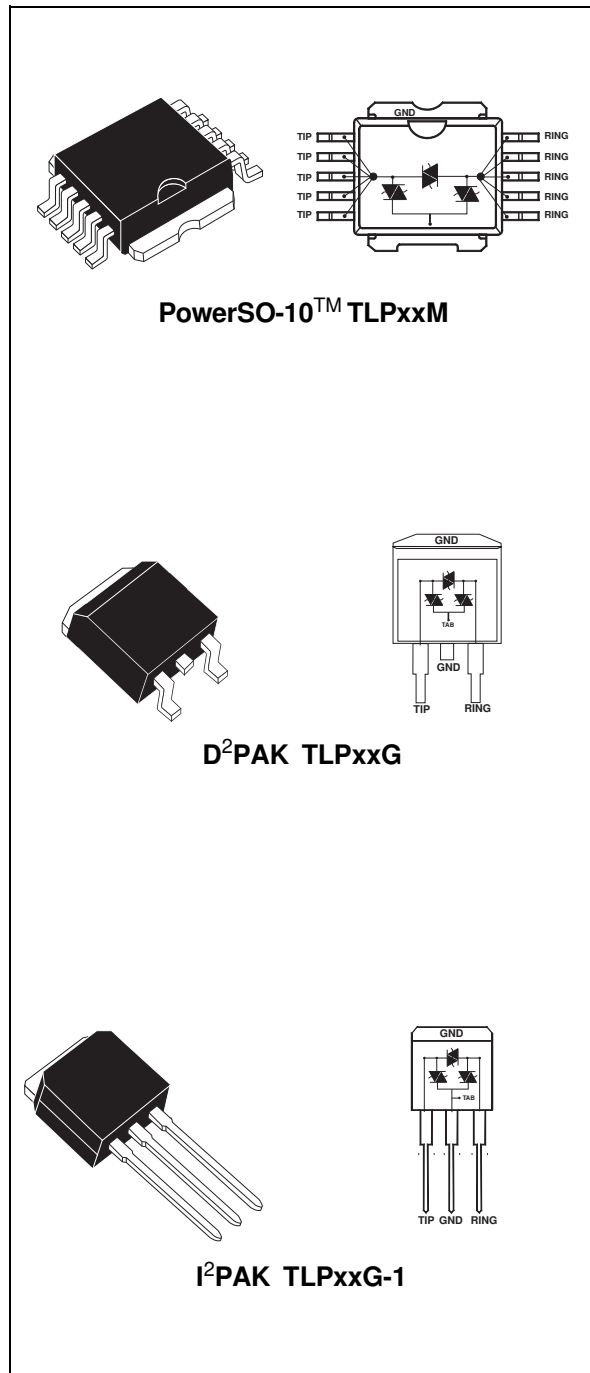

TM: ASD and PowerSO-10 are trademarks of ST Microelectronics.

September 1998 - Ed : 3C

TLPxxM/G/G-1

COMPLIES WITH THE FOLLOWING STANDARDS:	Peak Surge Voltage (V)	Voltage Waveform (μs)	Current Waveform (μs)	Admissible Ipp (A)	Necessary Resistor (Ω)
CCITT K20	4000	10/700	5/310	100	-
VDE0433	4000	10/700	5/310	100	-
VDE0878	4000	1.2/50	1/20	100	-
IEC-1000-4-5	level 4 level 4	10/700 1.2/50	5/310 8/20	100 100	- -
FCC Part 68, lightning surge type A	1500 800	10/160 10/560	10/160 10/560	200 100	- -
FCC Part 68, lightning surge type B	1000	5/320	5/320	25	-
BELLCORE TR-NWT-001089 FIRST LEVEL	2500 1000	2/10 10/1000	2/10 10/1000	500 100	- -
BELLCORE TR-NWT-001089 SECOND LEVEL	5000	2/10	2/10	500	-
CNET I31-24	4000	0.5/700	0.8/310	100	-

TYPICAL APPLICATION Primary protection module

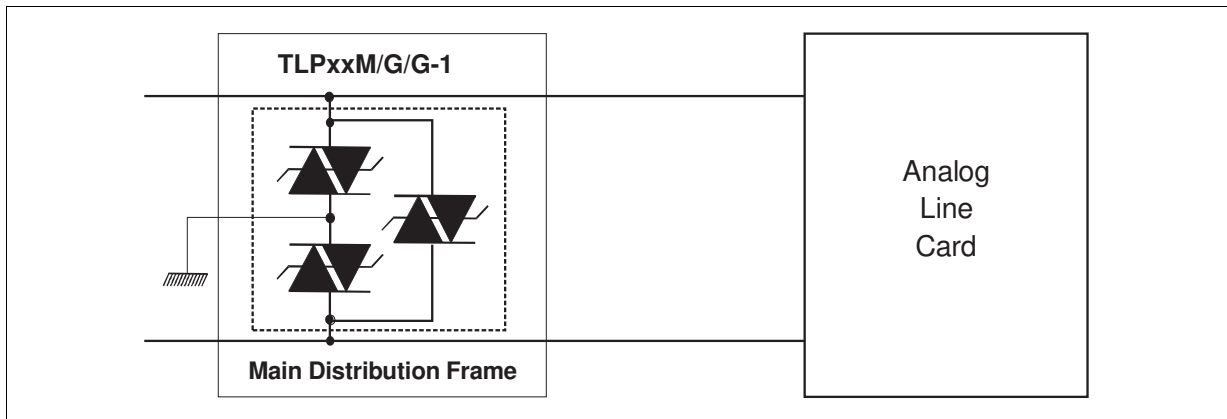

Analog line card protection

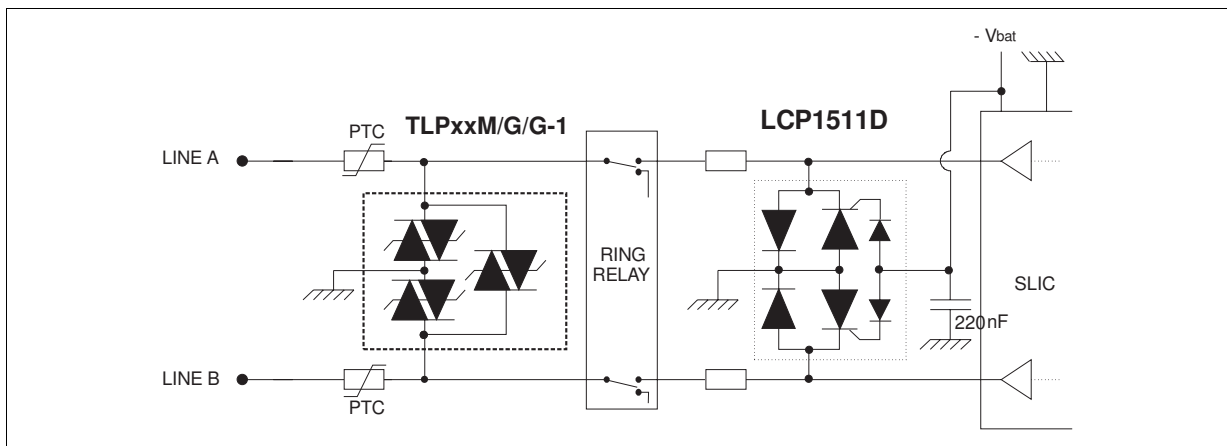

TYPICAL APPLICATION
ISDN: U interface protection

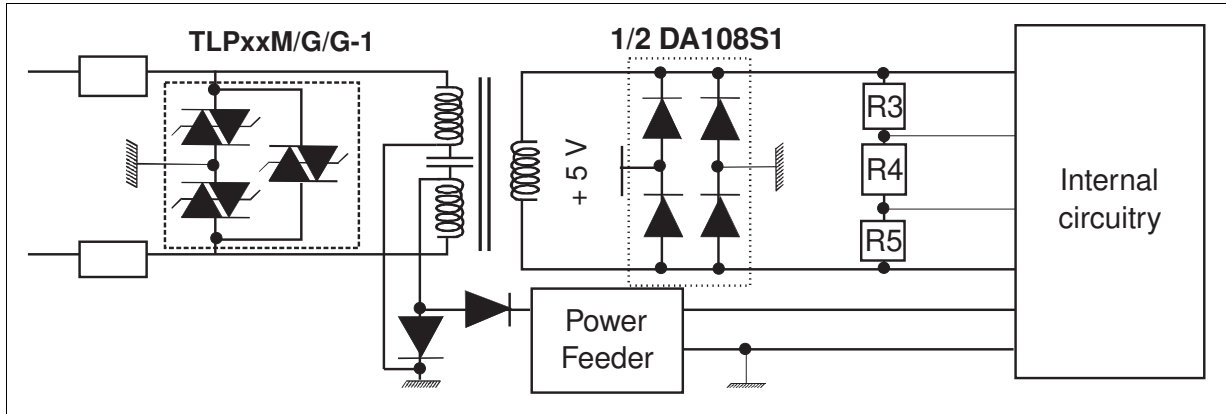

PARAMETER MEASUREMENT INFORMATION

Symbol	Description
I _{PP}	Peak pulse current
I _{TSM}	Maximum peak on-state current
I _R	Leakage current
I _{RM}	Leakage current
I _H	Holding current
V _{BR}	Breakdown voltage
V _R	Continuous reverse voltage
V _{RM}	Maximum stand-off voltage
V _{BO}	Breakover voltage
C	Capacitance

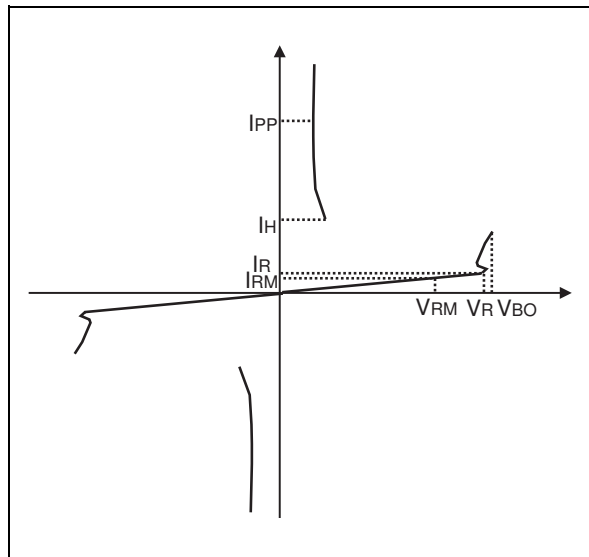

ABSOLUTE MAXIMUM RATINGS (T_{amb} = 25°C)

Symbol	Parameter	Value	Unit	
I _{PP}	Peak pulse current (longitudinal & transversal mode) :			
	10/1000 μs (open circuit voltage waveform 1 kV 10/1000 μs)	100	A	
	8/20 μs (open circuit voltage waveform 4 kV 1.2/50 μs)	250	A	
	2/10 μs (open circuit voltage waveform 2.5kV 2/10 μs)	500	A	
I _{TSM}	Mains power induction V _{RMS} = 300V, R = 600Ω	t = 200ms	0.7	A
	Mains power contact V _{RMS} = 220V, R = 10Ω (Fail-Safe threshold)	t = 200 ms	31	A
	V _{RMS} = 220V, R = 600Ω	t = 15 mn	0.42	A
T _{stg}	Storage temperature range	- 55 to + 150	°C	
T _j	Maximum operating junction temperature	150	°C	
T _L	Maximum lead temperature for soldering during 10 s	260	°C	
T _{OP}	Operating temperature range	- 40 to + 85	°C	

TLPxxM/G/G-1

THERMAL RESISTANCE

Symbol	Parameter		Value	Unit
Rth (j-c)	Junction to case	TLPxxM	1.0	°C/W
		TLPxxG	1.0	
		TLPxxG-1	1.0	
Rth (j-a)	Junction to ambient	TLPxxM	see table page 14	°C/W
		TLPxxG	see table page 14	
		TLPxxG-1	see table page 14	

ELECTRICAL CHARACTERISTICS BETWEEN TIP AND RING ($T_{amb} = 25^{\circ}\text{C}$)

Type	$I_{RM} @ V_{RM}$ max.		$I_R @ V_R$ max.		C typ. note
	μA	V	μA	V	pF
TLP140M/G/G-1	5	120	50	140	35
TLP200M/G/G-1	5	180	50	200	35
TLP270M/G/G-1	5	230	50	270	35

Note : $V_R = 50\text{ V}$ bias, $V_{RMS} = 1\text{ V}$, $F = 1\text{ MHz}$.

ELECTRICAL CHARACTERISTICS BETWEEN TIP AND GND, RING AND GND ($T_{amb} = 25^{\circ}\text{C}$)

Type	$I_{RM} @ V_{RM}$ max.		$I_R @ V_R$ max. note 1		$V_{BO} @ I_{BO}$ max. max. note 2		IH min. note 3	C @ V_R typ. note 4 note 5	
	μA	V	μA	V	V	mA	mA	pF	pF
TLP140M/G/G-1	5	120	50	140	200	500	150	110	40
TLP200M/G/G-1	5	180	50	200	290	500	150	110	40
TLP270M/G/G-1	5	230	50	270	400	500	150	110	40

Note 1: I_R measured at V_R guarantees $V_{BR\ min} > V_R$.

Note 2: Measured at 50 Hz.

Note 3: See functional holding current test circuit.

Note 4: $V_R = 0\text{ V}$ bias, $V_{RMS} = 1\text{ V}$, $F = 1\text{ MHz}$.

Note 5: $V_R = 50\text{ V}$ bias, $V_{RMS} = 1\text{ V}$, $F = 1\text{ MHz}$ (TIP or RING (-) / GND (+)).

FUNCTIONAL HOLDING CURRENT (I_H) TEST CIRCUIT: GO-NO GO TEST

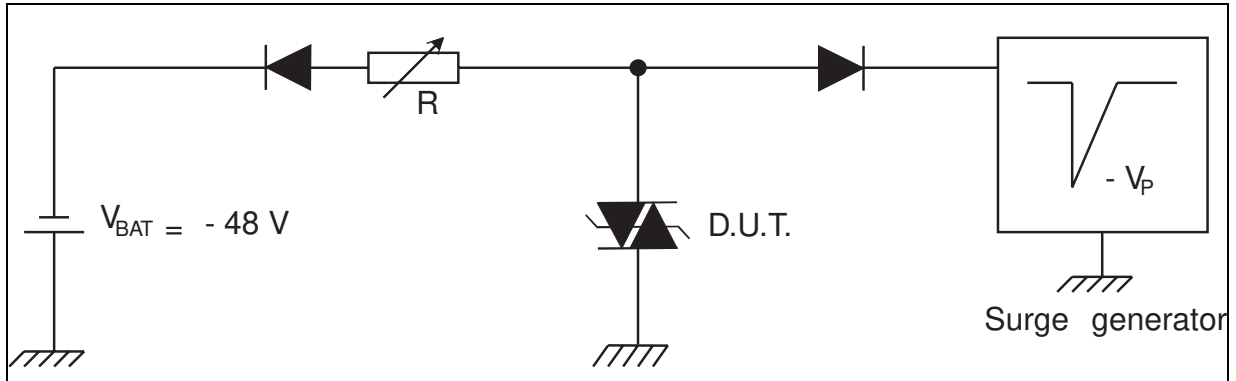

This is a GO-NO GO test which allows to confirm the holding current (I_H) level in a functional test circuit.

TEST PROCEDURE :

- Adjust the current level at the I_H value by short circuiting the D.U.T.
- Fire the D.U.T. with a surge current : $I_{PP} = 10A, 10/1000\mu s$.
- The D.U.T. will come back to the off-state within a duration of 50ms max.

MARKING

Package	Types	Marking
PowerSO-10	TLP140M TLP200M TLP270M	TLP140M TLP200M TLP270M
D ² PAK	TLP140G TLP200G TLP270G	TLP140G TLP200G TLP270G
I ² PAK	TLP140G-1 TLP200G-1 TLP270G-1	TLP140G TLP200G TLP270G

ORDER CODE

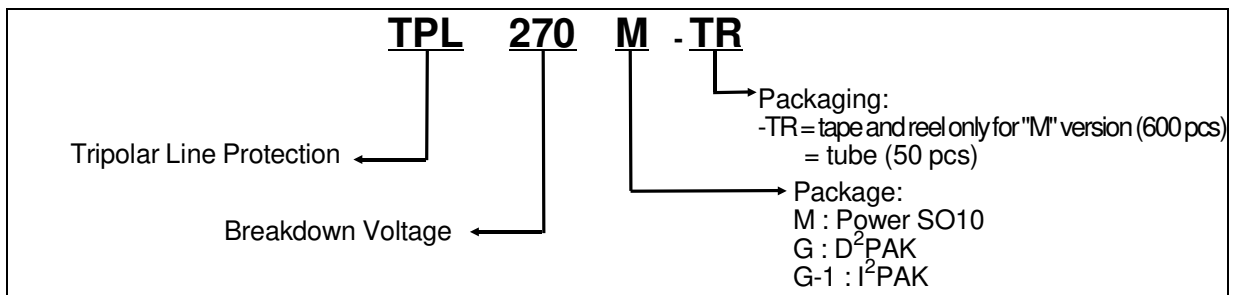

TLPxxM/G/G-1

Fig. 1: Maximum peak on-state current versus pulse duration.

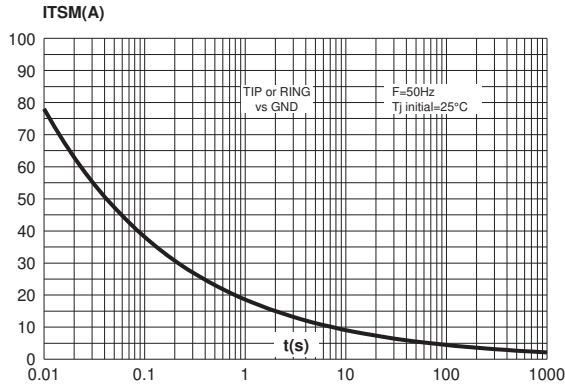

Fig. 3-1: junction capacitance versus applied reverse voltage (typical values) (TLP140M/G/G-1).

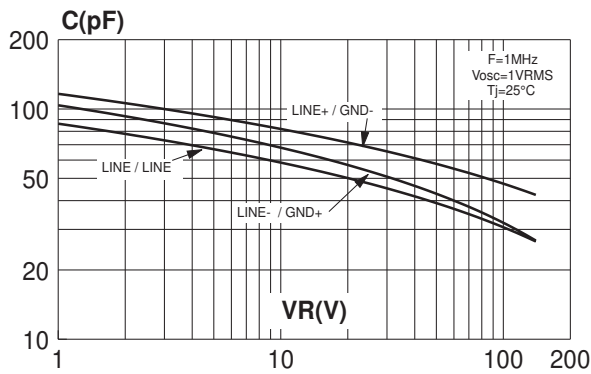

Fig. 3-3: junction capacitance versus applied reverse voltage (typical values) (TLP270M/G/G-1).

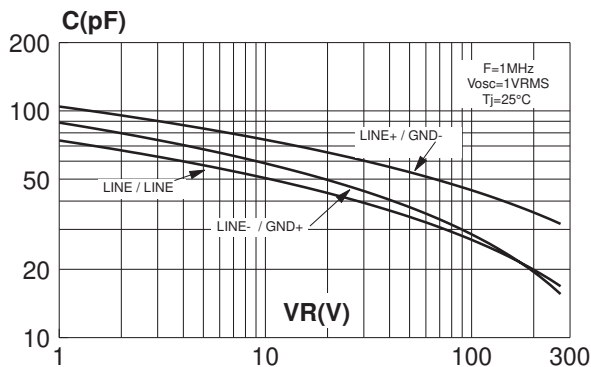

Fig. 2: Relative variation of I_H versus T_{amb} .

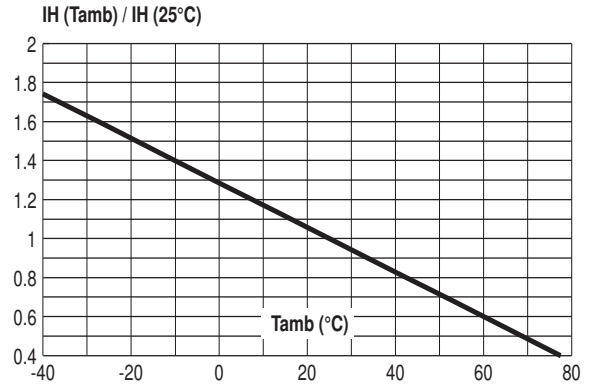

Fig. 3-2: junction capacitance versus applied reverse voltage (typical values) (TLP200M/G/G-1).

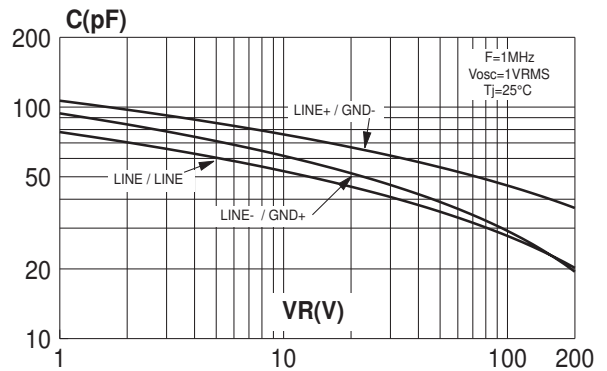

Fig. 4: Test diagram for breakover voltage measurement.

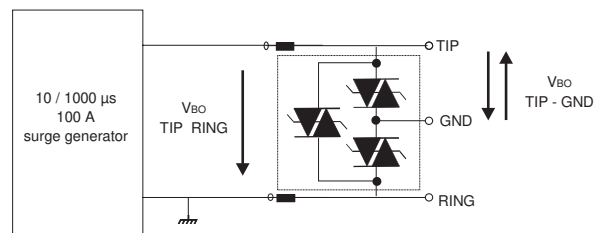

Fig. 5-1 : Breakover voltage measurement (TLP140M/G/G-1).

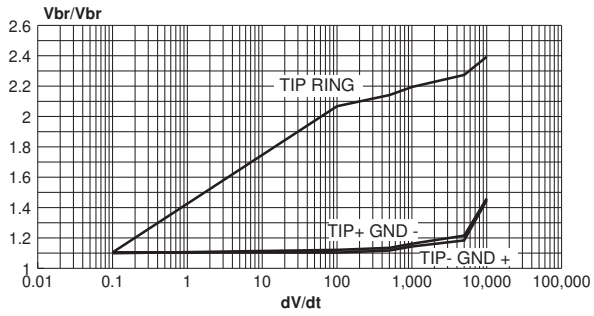

Fig. 5-2 : Breakover voltage measurement (TLP200M/G/G-1).

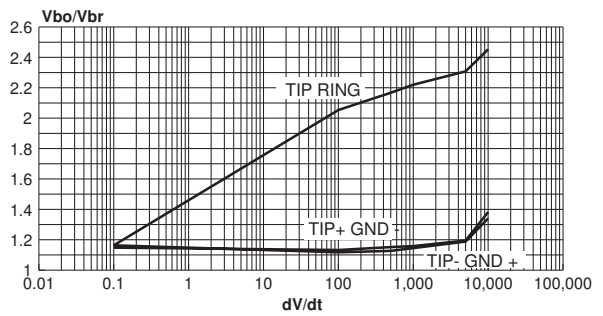
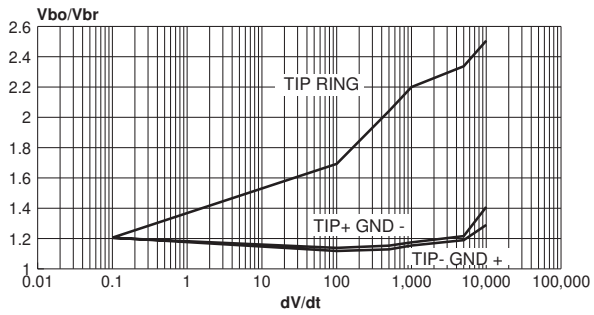
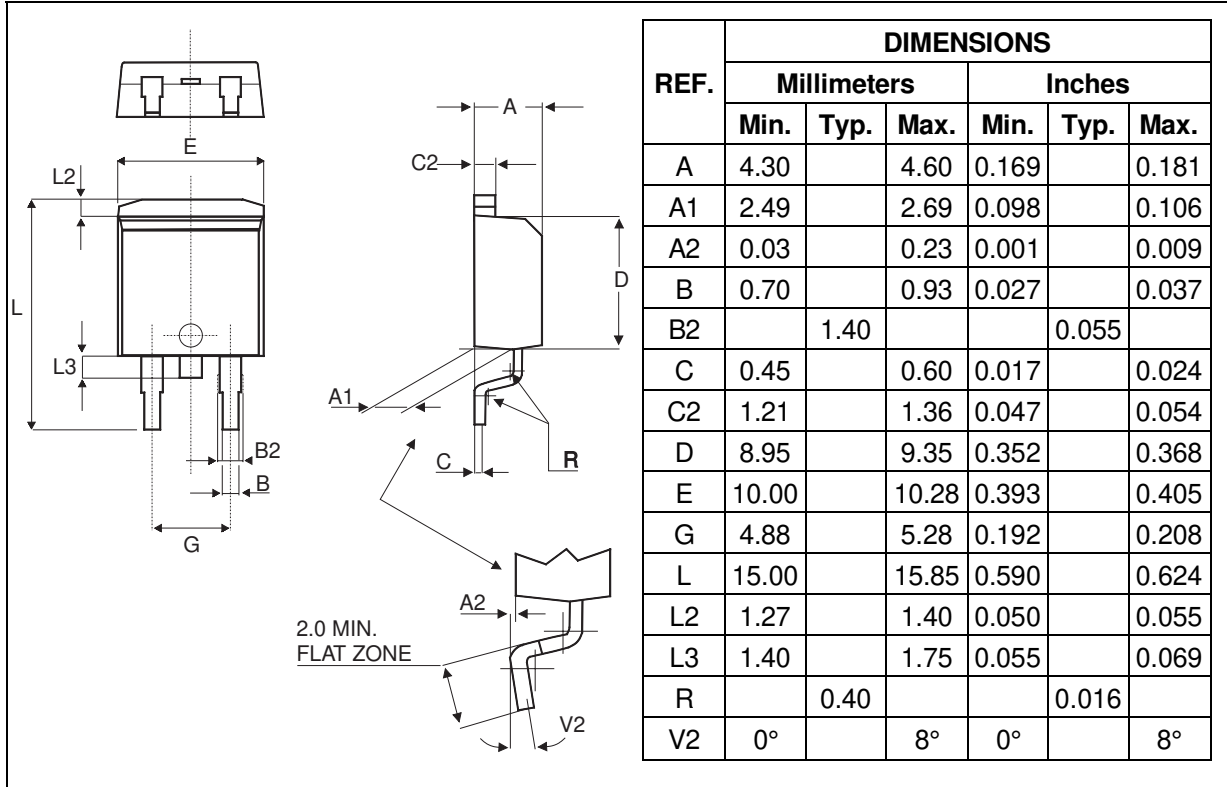

Fig. 5-3 : Breakover voltage measurement (TLP270M/G/G-1).



TLPxxM/G/G-1

PACKAGE MECHANICAL DATA
D²PAK Plastic



FOOT-PRINT D²PAK

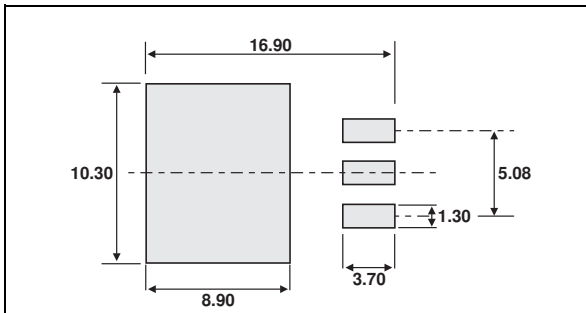

PACKAGE MECHANICAL DATA
I²PAK Plastic

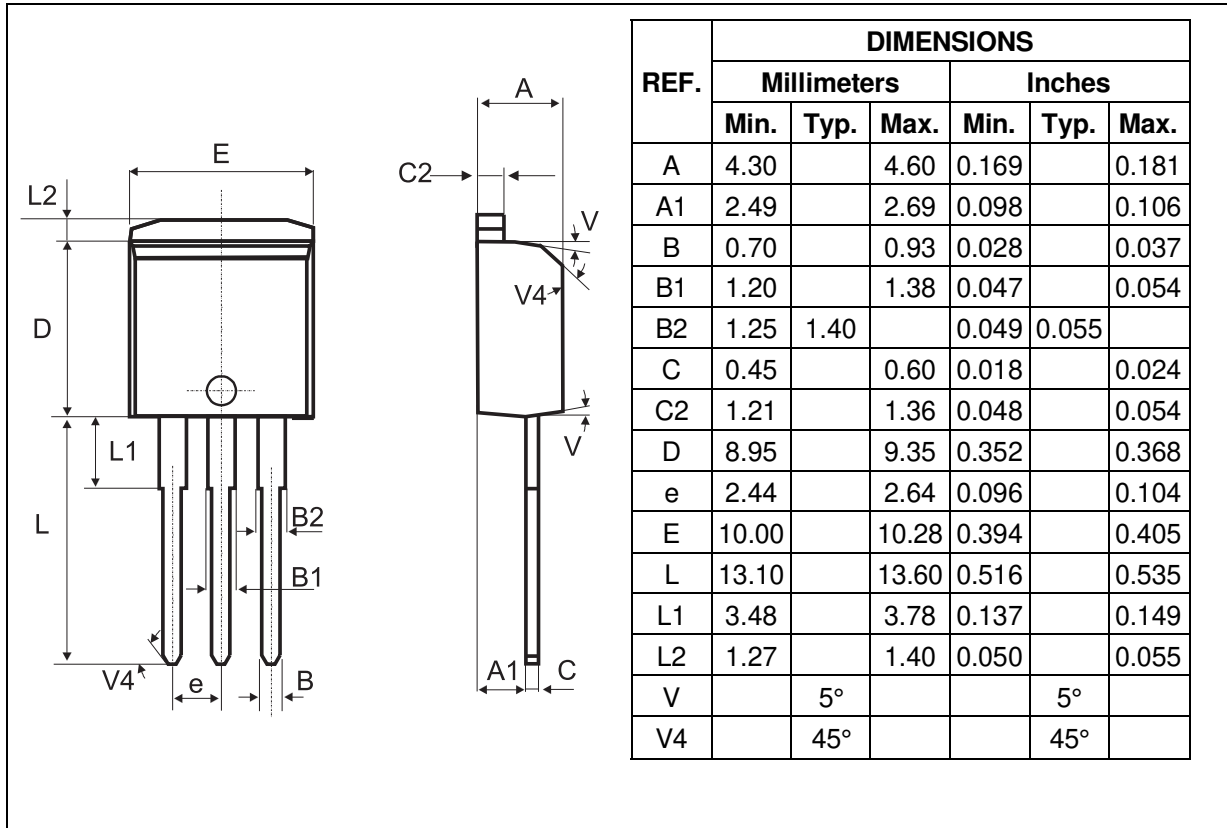

TLPxxM/G/G-1

PACKAGE MECHANICAL DATA
Power-SO10

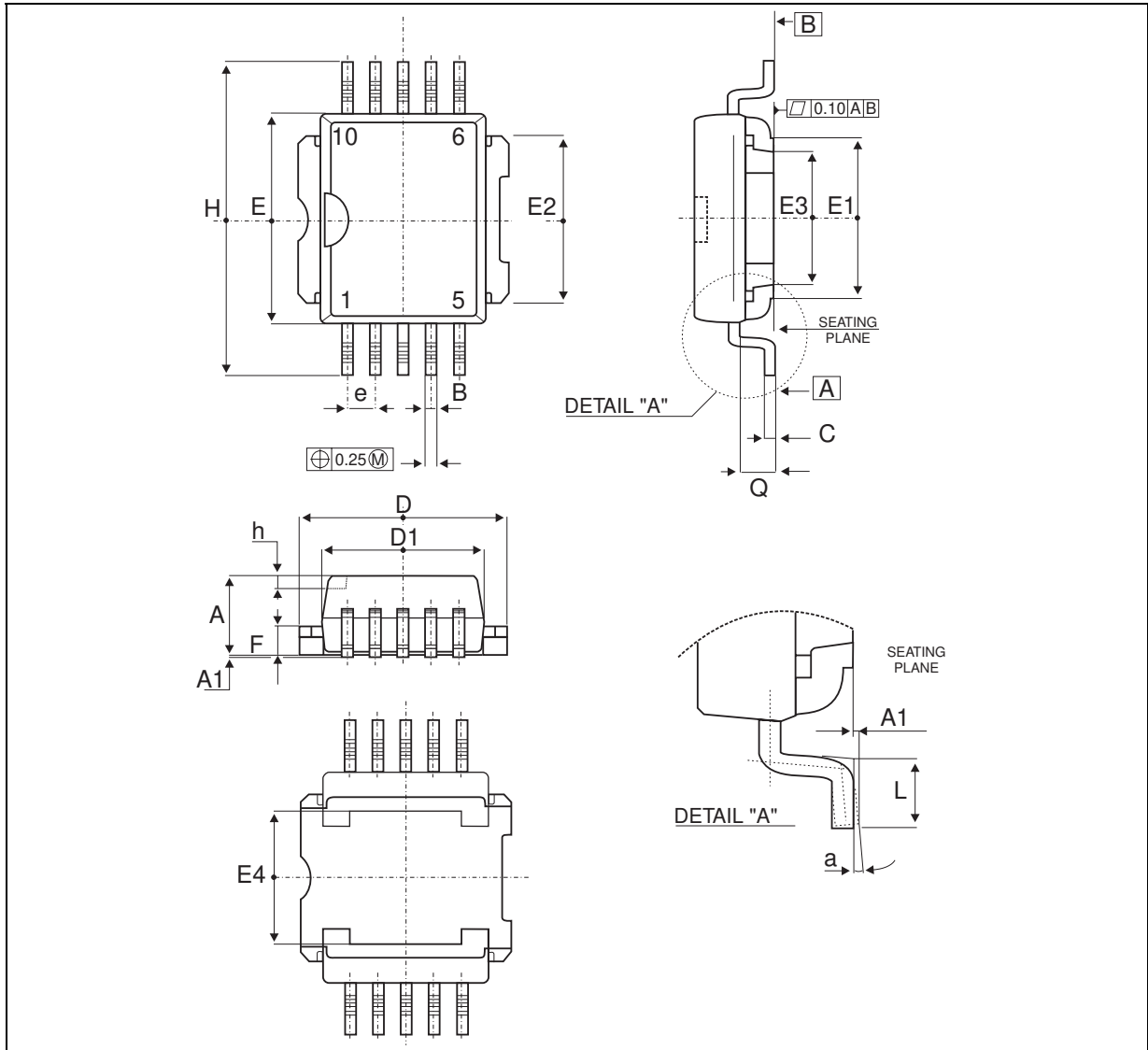

REF.	DIMENSIONS					
	Millimeters			Inches		
	Min.	Typ.	Max.	Min.	Typ.	Max.
A	3.35		3.65	0.131		0.143
A1	0.00		0.10	0.00		0.0039
B	0.40		0.60	0.0157		0.0236
C	0.35		0.55	0.0137		0.0217
D	9.40		9.60	0.370		0.378
D1	7.40		7.60	0.291		0.299
E	9.30		9.50	0.366		0.374
E1	7.20		7.40	0.283		0.291
E2	7.20		7.60	0.283		0.299

REF.	DIMENSIONS					
	Millimeters			Inches		
	Min.	Typ.	Max.	Min.	Typ.	Max.
E3	6.10		6.35	0.240		0.250
E4	5.90		6.10	0.232		0.240
e		1.27			0.05	
F	1.25		1.35	0.0492		0.0531
H	13.80		14.40	0.543		0.567
h		0.50			0.019	
L	1.20		1.80	0.0472		0.0708
Q		1.70			0.067	
a	0°		8°	0°		8°

**FOOT PRINT Power-SO10
MOUNTING PAD LAYOUT
RECOMMENDED**

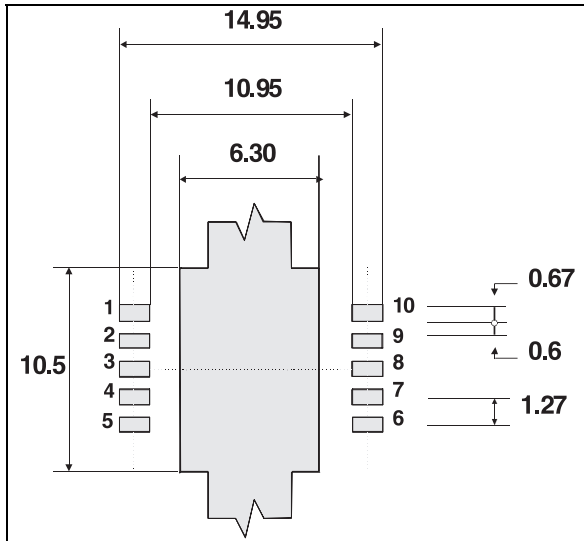

Dimensions in millimeters

HEADER SHAPE

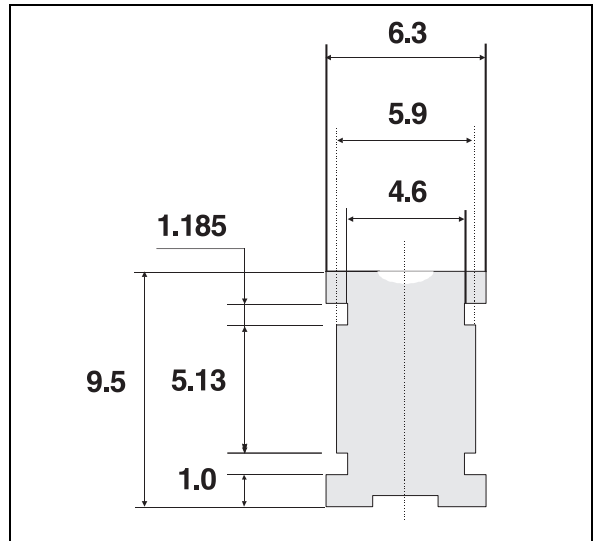

Dimensions in millimeters

SHIPPING TUBE

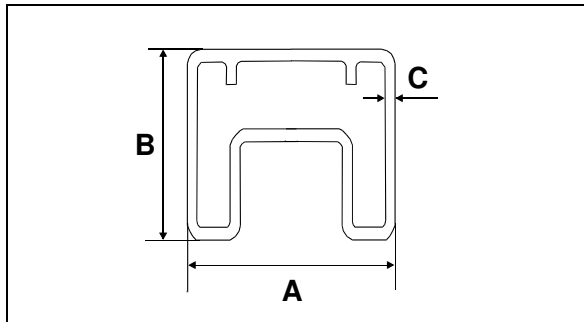

	DIMENSIONS (mm)
	TYP
A	18
B	12
C	0,8
Length tube	532
Quantity per tube	50

Surface mount film taping : contact sales office

SOLDERING RECOMMENDATION

The soldering process causes considerable thermal stress to a semiconductor component. This has to be minimized to assure a reliable and extended lifetime of the device. The PowerSO-10 package can be exposed to a maximum temperature of 260°C for 10 seconds. However a proper soldering of the package could be done at 215°C for 3 seconds. Any solder temperature profile should be within these limits. As reflow techniques are most common in surface mounting, typical heating profiles are given in Figure 1, either for mounting on FR4 or on metal-backed boards. For each particular board, the appropriate heat profile has to be adjusted experimentally. The present proposal is just a starting point. In any case, the following precautions have to be considered :

- always preheat the device
- peak temperature should be at least 30 °C higher than the melting point of the solder alloy chosen
- thermal capacity of the base substrate

Voids pose a difficult reliability problem for large surface mount devices. Such voids under the package result in poor thermal contact and the high thermal resistance leads to component failures. The PowerSO-10 is designed from scratch to be solely a surface mount package, hence symmetry in the x- and y-axis gives the package excellent weight balance. Moreover, the PowerSO-10 offers the unique possibility to control easily the flatness and quality of the soldering process. Both the top and the bottom soldered edges of the package are accessible for visual inspection (soldering meniscus).

Coplanarity between the substrate and the package can be easily verified. The quality of the solder joints is very important for two reasons : (I) poor quality solder joints result directly in poor reliability and (II) solder thickness affects the thermal resistance significantly. Thus a tight control of this parameter results in thermally efficient and reliable solder joints.

Fig. 1 : Typical reflow soldering heat profile

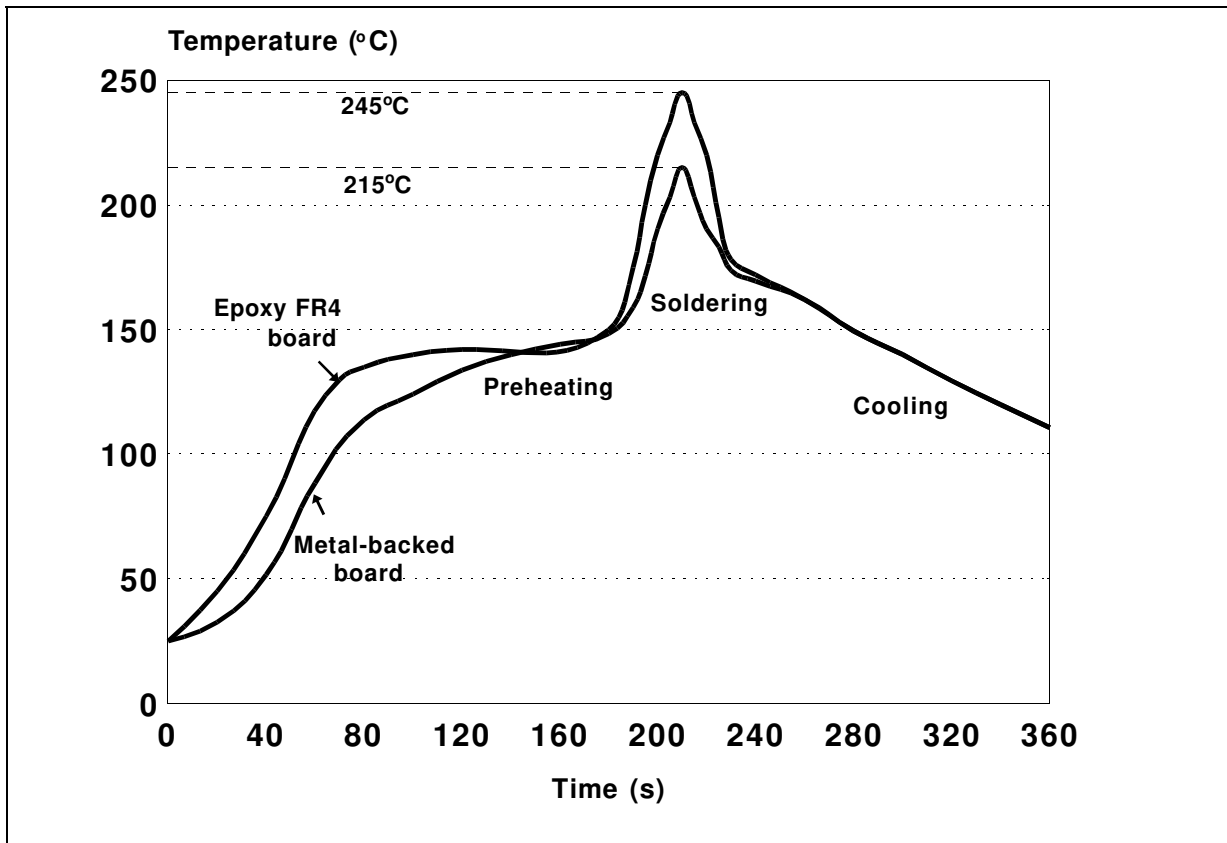

SUBSTRATES AND MOUNTING INFORMATION

The use of epoxy FR4 boards is quite common for surface mounting techniques, however, their poor thermal conduction compromises the otherwise outstanding thermal performance of the PowerSO-10. Some methods to overcome this limitation are discussed below.

One possibility to improve the thermal conduction is the use of large heat spreader areas at the copper layer of the PC board. This leads to a reduction of thermal resistance to 35 °C for 6 cm² of the board heatsink (see fig. 2).

Use of copper-filled through holes on conventional FR4 techniques will increase the metallization and

decrease thermal resistance accordingly. Using a configuration with 16 holes under the spreader of the package with a pitch of 1.8 mm and a diameter of 0.7 mm, the thermal resistance (junction - heatsink) can be reduced to 12°C/W (see fig. 3). Beside the thermal advantage, this solution allows multi-layer boards to be used. However, a drawback of this traditional material prevents its use in very high power, high current circuits. For instance, it is not advisable to surface mount devices with currents greater than 10 A on FR4 boards. A Power Mosfet or Schottky diode in a surface mount power package can handle up to around 50 A if better substrates are used.

Fig. 2 : Mounting on epoxy FR4 head dissipation by extending the area of the copper layer

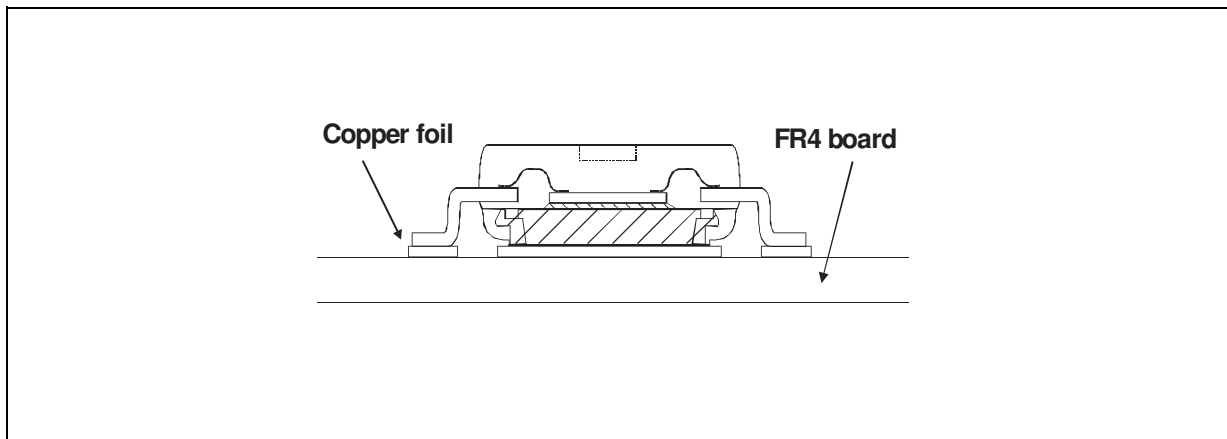
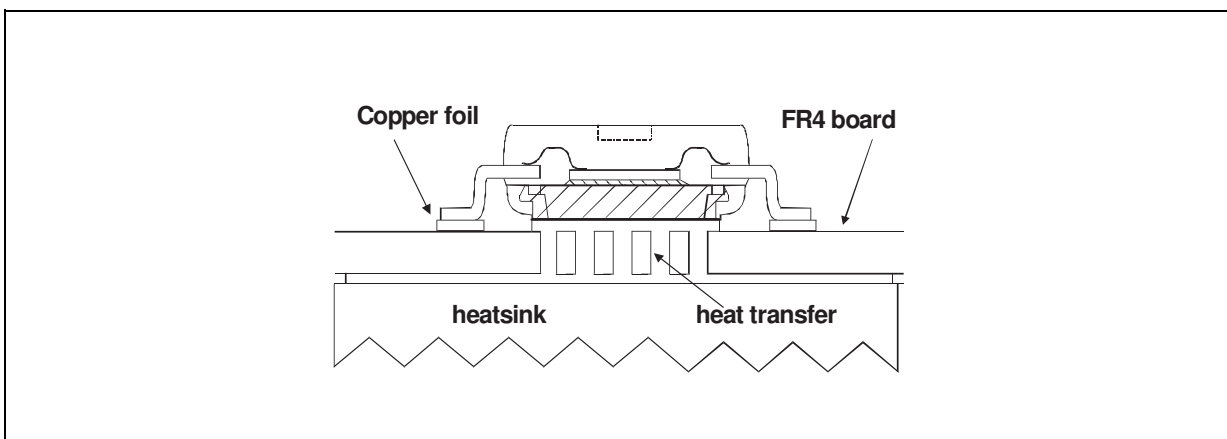

Fig. 3 : Mounting on epoxy FR4 by using copper-filled through holes for heat transfer



TLPxxM/G/G-1

A new technology available today is IMS - an Insulated Metallic Substrate. This offers greatly enhanced thermal characteristics for surface mount components. IMS is a substrate consisting of three different layers, (I) the base material which is available as an aluminium or a copper plate, (II) a thermal conductive dielectrical layer and (III) a copper foil, which can be etched as a circuit layer. Using this material a thermal resistance of 8°C/W with 40 cm² of board floating in air is achievable (see fig. 4). If even higher power is to be dissipated an external heatsink could be applied which leads to an R_{th(j-a)} of 3.5°C/W (see Fig. 5), assuming that R_{th} (heatsink-air) is equal to R_{th} (junction-heatsink). This is commonly applied in practice, leading to reasonable heatsink dimensions. Often power devices are defined by considering the

maximum junction temperature of the device. In practice, however, this is far from being exploited. A summary of various power management capabilities is made in table 1 based on a reasonable delta T of 70°C junction to air.

The PowerSO-10 concept also represents an attractive alternative to C.O.B. techniques. PowerSO-10 offers devices fully tested at low and high temperature. Mounting is simple - only conventional SMT is required - enabling the users to get rid of bond wire problems and the problem to control the high temperature soft soldering as well. An optimized thermal management is guaranteed through PowerSO-10 as the power chips must in any case be mounted on heat spreaders before being mounted onto the substrate.

Fig. 4 : Mounting on metal backed board

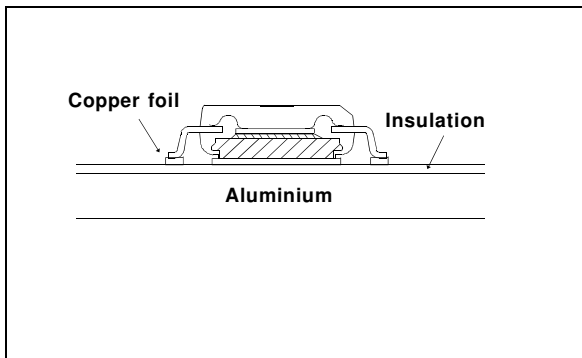

Fig. 5 : Mounting on metal backed board with an external heatsink applied

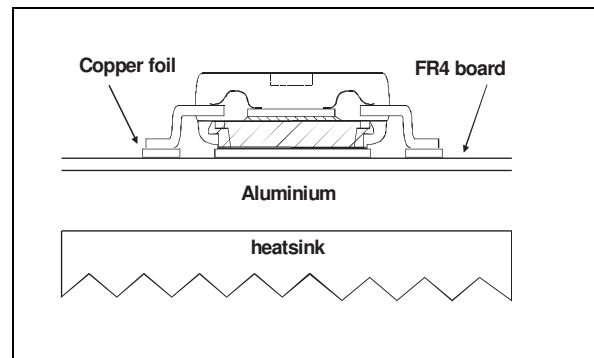

TABLE 1

Printed circuit board material	R _{th} (j-a)	P Diss
1.FR4 using the recommended pad-layout	50 °C/W	1.5 W
2.FR4 with heatsink on board (6cm ²)	35 °C/W	2.0 W
3.FR4 with copper-filled through holes and external heatsink applied	12 °C/W	5.8 W
4. IMS floating in air (40 cm ²)	8 °C/W	8.8 W
5. IMS with external heatsink applied	3.5 °C/W	20 W

Information furnished is believed to be accurate and reliable. However, STMicroelectronics assumes no responsibility for the consequences of use of such information nor for any infringement of patents or other rights of third parties which may result from its use. No license is granted by implication or otherwise under any patent or patent rights of STMicroelectronics. Specifications mentioned in this publication are subject to change without notice. This publication supersedes and replaces all information previously supplied.

STMicroelectronics products are not authorized for use as critical components in life support devices or systems without express written approval of STMicroelectronics.

The ST logo is a registered trademark of STMicroelectronics

© 1998 STMicroelectronics - Printed in Italy - All rights reserved.

STMicroelectronics GROUP OF COMPANIES

Australia - Brazil - Canada - China - France - Germany - Italy - Japan - Korea - Malaysia - Malta - Mexico - Morocco - The Netherlands - Singapore - Spain - Sweden - Switzerland - Taiwan - Thailand - United Kingdom - U.S.A.

<http://www.st.com>