



Chipsmall Limited consists of a professional team with an average of over 10 year of expertise in the distribution of electronic components. Based in Hongkong, we have already established firm and mutual-benefit business relationships with customers from,Europe,America and south Asia,supplying obsolete and hard-to-find components to meet their specific needs.

With the principle of “Quality Parts,Customers Priority,Honest Operation,and Considerate Service”,our business mainly focus on the distribution of electronic components. Line cards we deal with include Microchip,ALPS,ROHM,Xilinx,Pulse,ON,Everlight and Freescale. Main products comprise IC,Modules,Potentiometer,IC Socket,Relay,Connector.Our parts cover such applications as commercial,industrial, and automotives areas.

We are looking forward to setting up business relationship with you and hope to provide you with the best service and solution. Let us make a better world for our industry!



Contact us

Tel: +86-755-8981 8866 Fax: +86-755-8427 6832

Email & Skype: info@chipsmall.com Web: www.chipsmall.com

Address: A1208, Overseas Decoration Building, #122 Zhenhua RD., Futian, Shenzhen, China



Subminiature, LAN Modular Jack Connectors

TM11R-5M2 Series

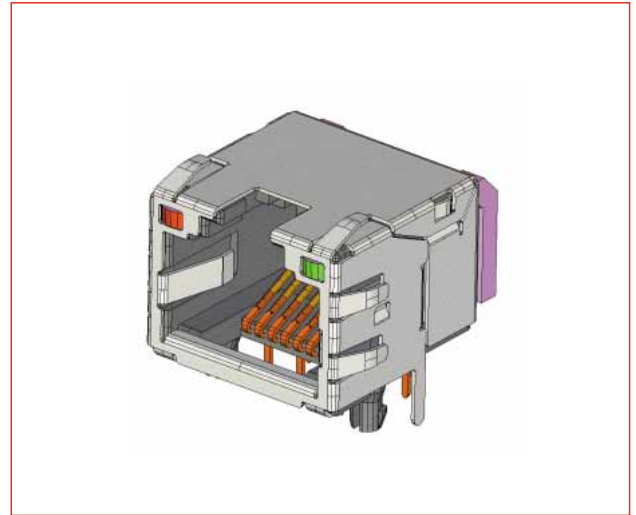
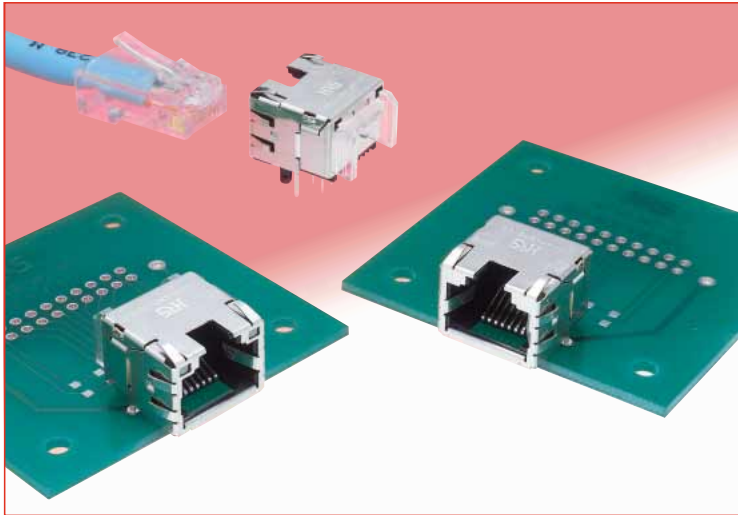

■ Features

1. Fast Ethernet Support

Conforms to the TIA/EIA-568-A data wiring standard and meets requirements of CAT5 transmission performance for 1,2-3,6 conductor pairs. As such, these products fully support Fast Ethernet (100BASE-TX) transmission.

2. Subminiature Design Contributes to Saving Space in the Equipment

Having built-in optical indicators, with height of only 11.5mm, width of 15mm and depth of 17.5mm the connectors can be used in extremely limited spaces.

3. Built-in Optical Indicators

Optical indicators are integral part of the connectors help saving space on customer's board.

Compared with LED type indicators, they do not emit any electrical noise.

4. EMI protection

Metal shield covers the outer surfaces of the connectors assuring complete protection against electromagnetic interference.

Built-in multiple shield and ground contacts assure reliable connection with the mounting panel as well as with the mating connectors.

5. Environmental considerations

Plating is lead-free in order to protect environment.

6. FCC Standards

Meets requirements of FCC Title 47, Part 68, Subpart F.

■ Applications

Telecom Hubs, Routers, Bridges and ATM Transmission Equipment, Ethernet Switches and Networking Equipment, Test and Measurement Equipment, Medical Diagnostic Equipment.

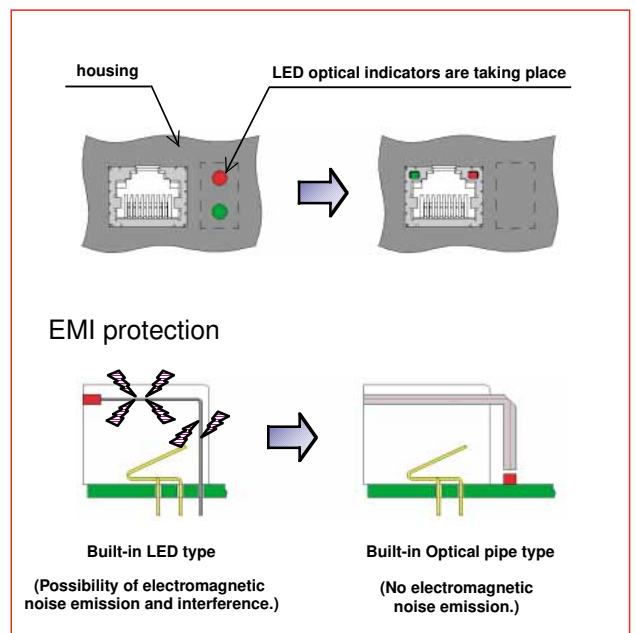
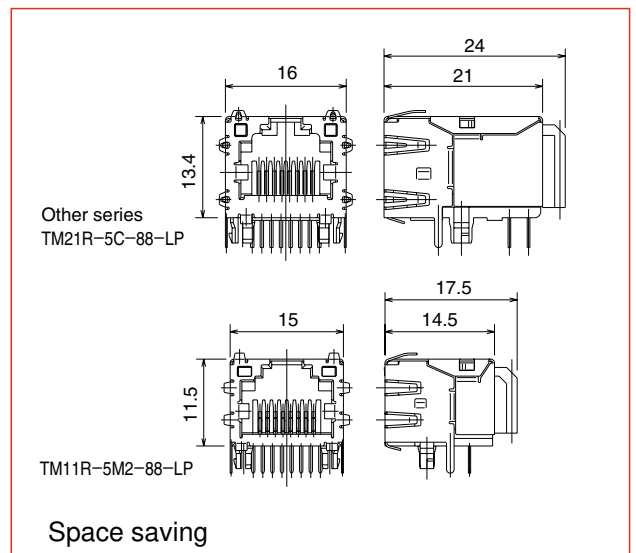

■ Product Specifications

Rating	Current rating 1A	Operating temperature range : -25°C to +80°C (Note)
	Voltage rating 125 V AC	

Item	Specification	Conditions
1. Insulation resistance	100 M ohms min.	100 V DC
2. Dielectric Withstanding Voltage (between adjacent contacts)	No flashover or insulation breakdown	500 V AC applied for one minute
3. Withstanding voltage (between contact and shield)	No flashover or insulation breakdown	1500 V AC / one minute
4. Contact resistance	230 m ohms max.	100mA
5. Vibration	No electrical discontinuity of 5 μ sec. or more. Contact resistance: 250m ohms max.	Frequency: 10 to 55 Hz, single amplitude of 0.75 mm, 2 hours / 3 axis
6. Shock	No electrical discontinuity of 5 μ sec. or more. Contact resistance: 250m ohms max.	Acceleration of 490 m/s ² , 11 ms duration, sine half-wave waveform, 3 cycles in each of the 3 axis
7. Durability (mating/un-mating)	Contact resistance: 250m ohms max.	200 cycles
8. Temperature cycle	Contact resistance: 250 m ohms max. Insulation resistance: 100 M ohms min.	Temperature: -55°C→+15°C to +35°C→+85°C→+15°C to +35°C Duration: 30→2 to 3→30→2 to 3(Minutes) 5 cycles
9. Humidity	Contact resistance: 250 m ohms max. Insulation resistance: 1 M ohms min. (High humidity) Insulation resistance: 10 M ohms min. (Dry state)	500 hours at temperature of 40°C and humidity of 90% to 95%
10. Salt Spray	Contact resistance: 250 m ohms max.	Exposed to density 5% salt water for 48 hours

Note :Includes temperature rise caused by current flow.

■ Materials

Part	Material	Finish	Remarks
Insulator	PBT	Color: Black	UL94V-0
Contact	Copper alloy	Contact area: Gold plating Termination area: Tin alloy plating	—
Optical pipe	Polycarbonate	Color: Transparent	UL94V-0
Shield	Copper alloy	Tin plating	—

■ Ordering information

● Jacks

TM11 R - 5M2 - 8 8 - LP

① ② ③ ④ ⑤ ⑥

① Series name	TM11 Series
② Connector type	R: Jack
③ Jack type	5M2: PCB Right-angle through hole type
④ Jack opening code	8: 8 contacts
⑤ Number of inserted contacts	8: 8 contact
⑥ Optical pipe	LP: With optical pipe inserted Blank: Without optical pipe

■ Modular Jack Connectors Supporting CAT5e (for 1,2-3,6 pair)

● Single Port With Built-in Optical Pipe

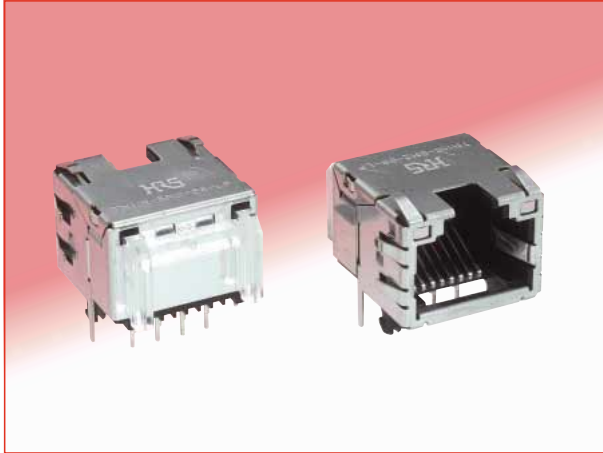

Part Number	CL No.	RoHS
TM11R-5M2-88-LP	222-2905-0	YES

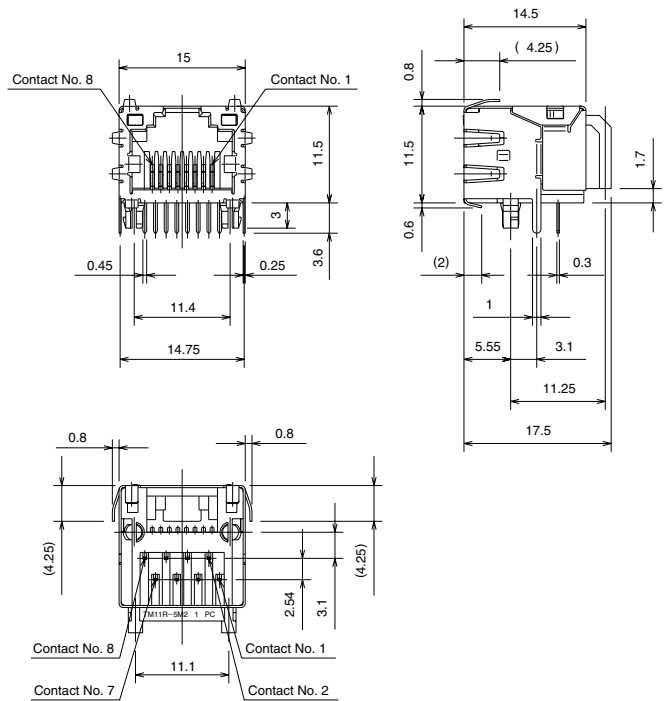

● Single Port Without Optical Pipe

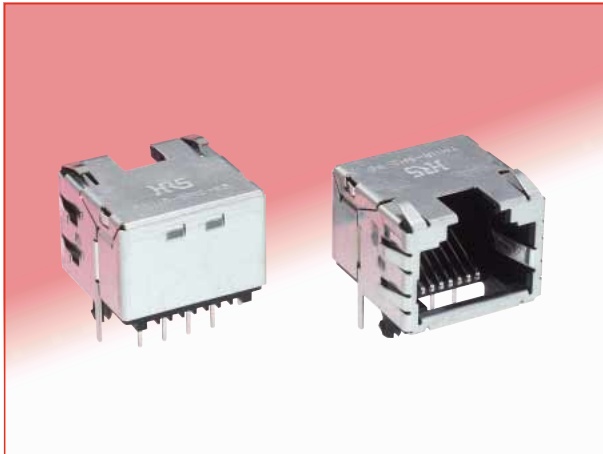

Part Number	CL No.	RoHS
TM11R-5M2-88	222-2906-2	YES

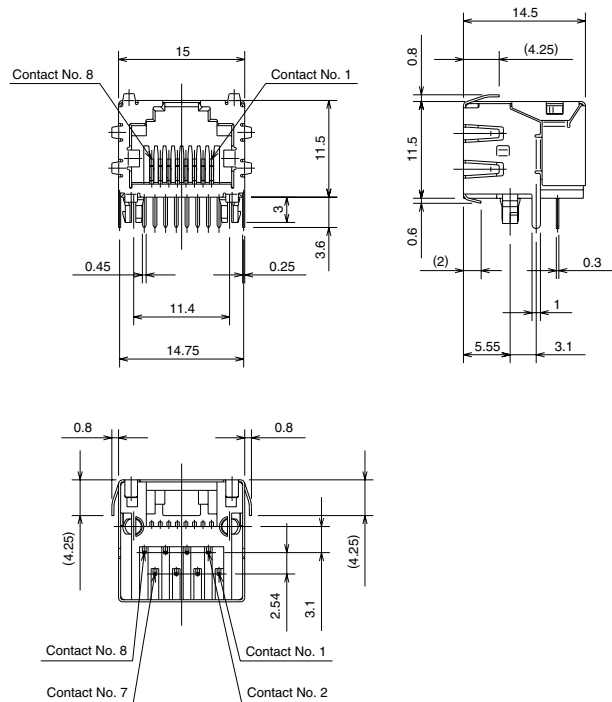

◆ Recommended PCB mounting patterns

● With Built-in Optical Pipe

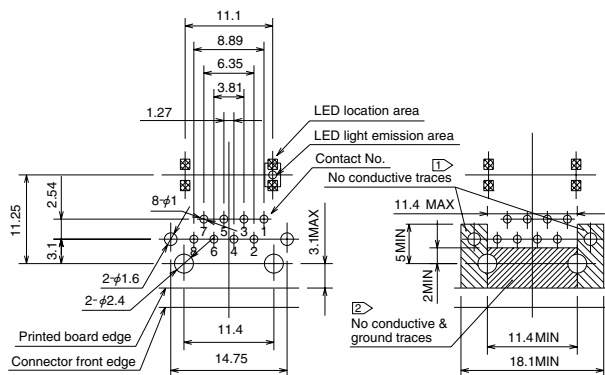

● Without Optical Pipe

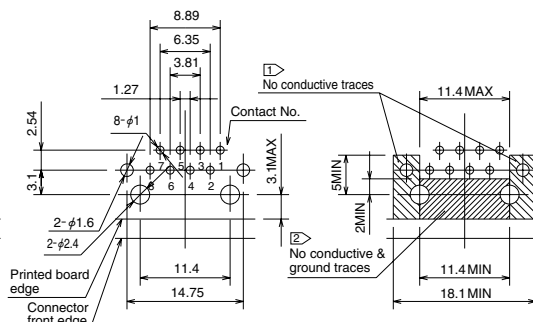

4 Suggested LEDs

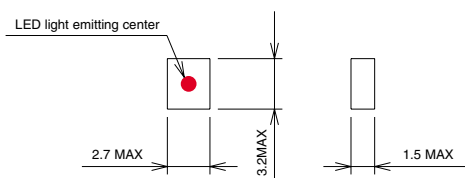

*Recommendations for PCB Design

- 1 Areas indicated should be free of conductive traces.
- 2 Area indicated should be free of conductive & ground traces.
- 3 Recommended board thickness: 1.6mm.
- 4 To assure that the indicator light pipes operates correctly the LED's must be installed directly on the PCB, within recommended dimensions and with light emitting center in upward direction. Contact applicable manufacturer for LED specification.

◆ Panel Cutout

● For Both Types, With and Without Built-in Optical Pipe

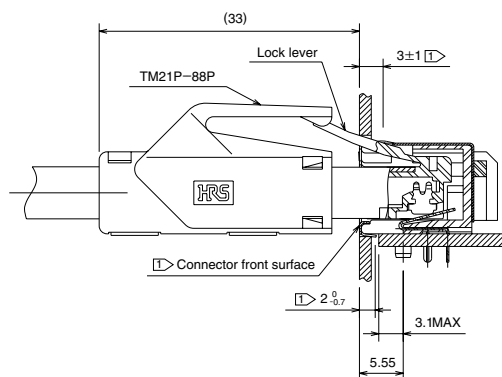
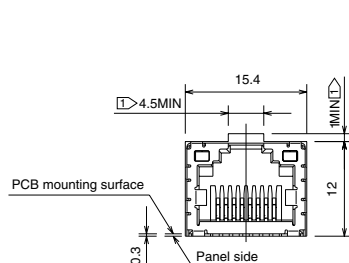

*Recommendations for Panel Design

- 1 The shield contacts should connect with the panel cut-out on all sides.

Note: IPA cleaning at room temperature is recommended for the cleaning of this product.

When an aqueous cleaning agent is to be used, there is a concern that the light pipe (made of polycarbonate resin) may change color; therefore, please make a selection based on a table showing the effects on the resin. These tables are issued by the various manufacturers of cleaning agents.

◆ CAT5 Transmission Characteristics Data

For fully mated receptacle (TM11R-5M2-88-LP) and plug (TM21P-88P).

● Signal Attenuation

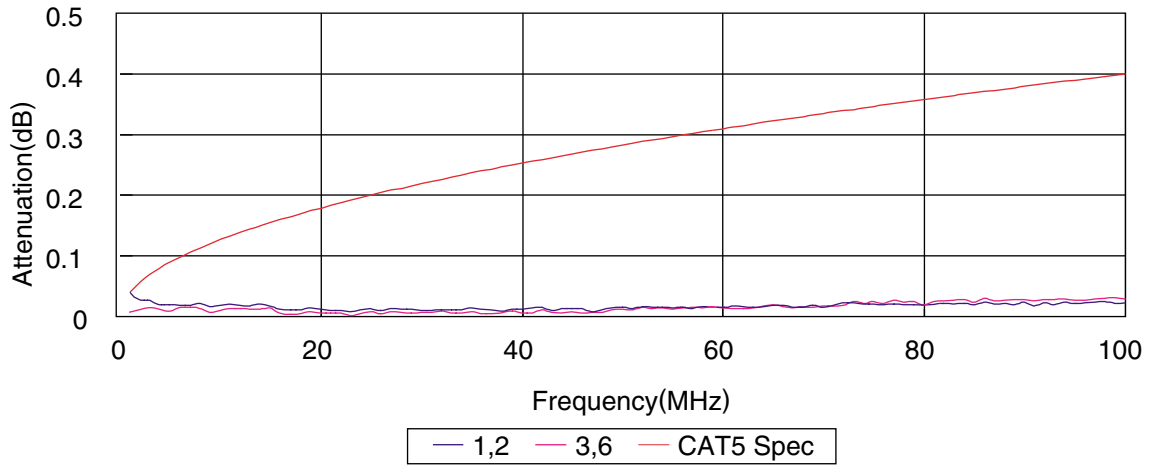

● Near-End Crosstalk (NEXT)

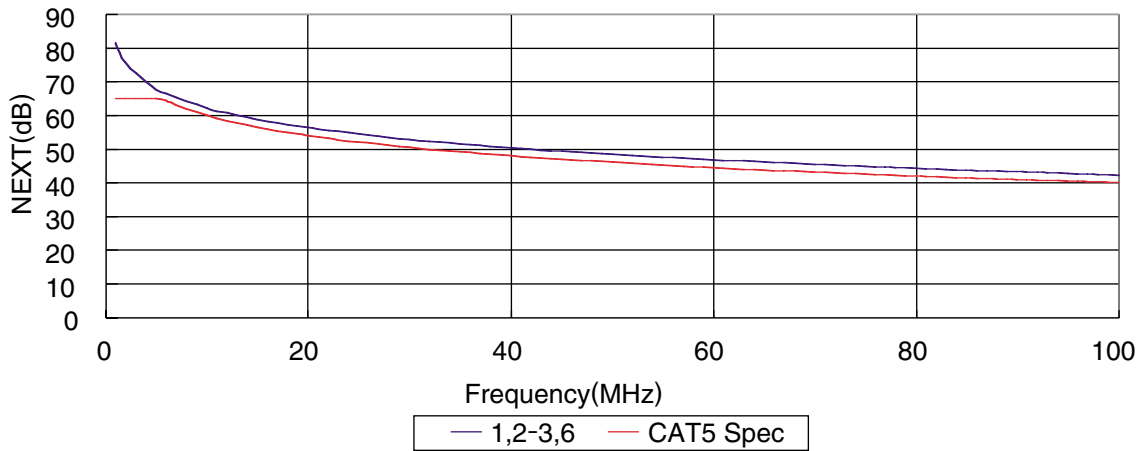

● Return Loss

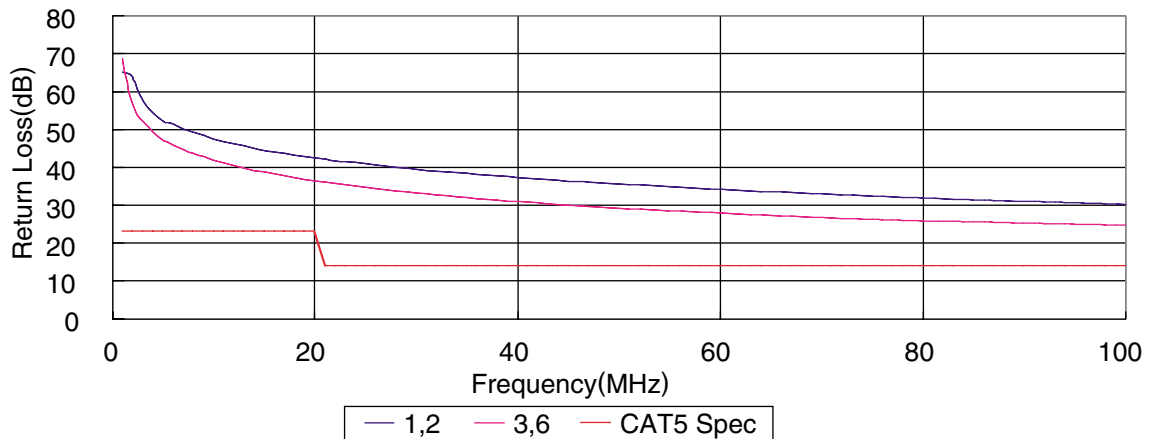

GUIDANCE FOR MODULAR CONNECTORS

■ Modular Connector Terminal Numbers

Unless otherwise specified, see the figures below for the terminal numbers of the product.

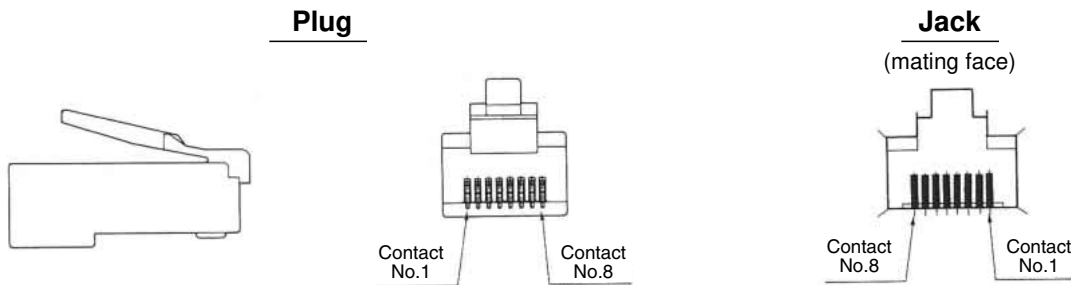

■ Attention to Plug Mating

Use only plugs conforming to FCC standards.
Please pay particular attention to dimensions shown right.

FCC PLUG DIMENSIONS

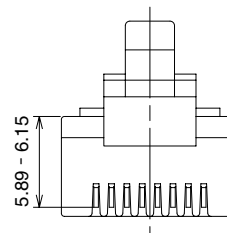

■ Opening Size and Number of Conductors(6-Conductor)

See the figures below for the relationship between the opening size and the number of conductors of the jack connectors.

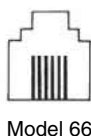

Models 64 and 62 are obtained by removing 1 pin and 2 pins, respectively, from both sides of model 66. For details, please contact us for drawings because only standard models are shown in the catalogs.

■ Recommended Soldering for Modular Dip Connectors

- Flow solder (automatic soldering machine)
 - Pre-heat : 90 - 130°C
 - Pre-heat time : 120 seconds maximum
 - Solder temperature : 240 - 260°C
 - Soldering time : 10 seconds maximum
- Hand soldering
 - Soldering iron tip temperature : 350°C
 - Soldering temperature : 5 seconds maximum
 - Soldering iron output : 30 - 40W

Note: When soldering, use care not to apply excessive force to the connector terminals.

- Recommended Solder composition: Paste, 96.5%Sn/3.0%Ag/0.5%Cu

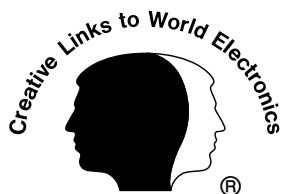

HIROSE ELECTRIC CO., LTD.

6-3, Nakagawa Chuoh-2-Chome, Tsuzuki-Ku, Yokohama-Shi 224-8540, JAPAN
 TEL: +81-45-620-3526 Fax: +81-45-591-3726
<http://www.hirose.com>
<http://www.hirose-connectors.com>