



Chipsmall Limited consists of a professional team with an average of over 10 year of expertise in the distribution of electronic components. Based in Hongkong, we have already established firm and mutual-benefit business relationships with customers from,Europe,America and south Asia,supplying obsolete and hard-to-find components to meet their specific needs.

With the principle of “Quality Parts,Customers Priority,Honest Operation,and Considerate Service”,our business mainly focus on the distribution of electronic components. Line cards we deal with include Microchip,ALPS,ROHM,Xilinx,Pulse,ON,Everlight and Freescale. Main products comprise IC,Modules,Potentiometer,IC Socket,Relay,Connector.Our parts cover such applications as commercial,industrial, and automotives areas.

We are looking forward to setting up business relationship with you and hope to provide you with the best service and solution. Let us make a better world for our industry!



Contact us

Tel: +86-755-8981 8866 Fax: +86-755-8427 6832

Email & Skype: info@chipsmall.com Web: www.chipsmall.com

Address: A1208, Overseas Decoration Building, #122 Zhenhua RD., Futian, Shenzhen, China



TMC5160 BOB Description

Document Revision V1.00 • 2017-Oct-19

Module Top View

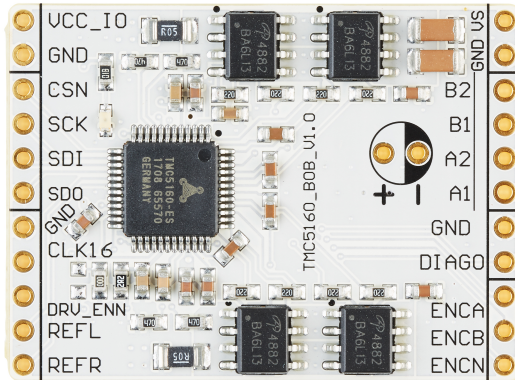

Features and additional Resources

- TMC5160-TA stepper controller
- Supply voltage 9-36V (limited by the MOSFETs)
- $I_{phase,RMS}$ up to 2.8A
- Configuration & Control via SPI
- S/D mode selectable via solder option
- Use with optional lowESR ELCO, ca. 150uF
- Board width 1.5", board height 1.1"
- 2x11 pin 0.1" header rows for pins/connectors
- Link to [additional information and IC data sheet](#)
- Link to [evaluation kit](#)

Pin List

Left	Signal	Right	Signal
1	VCC_IO (3.3V or 5V)	12	VS (9-36V)
2	GND	13	GND
3	CSN (active low)	14	B2 (Motor Phase B)
4	SCK (up to 6MHz with external CLK)	15	B1 (Motor Phase B)
5	SDI (data in)	16	A2 (Motor Phase A)
6	SDO (data out)	17	A1 (Motor Phase A)
7	GND	18	GND
8	CLK16 (pull to GND for internal CLK)	19	DIAGO (Diagnosis out)
9	DRV_ENN (active low)	20	ENCA (Incremental Enc.)
10	REFL (Left End Stop)	21	ENCB (Incremental Enc.)
11	REFR (Right End Stop)	22	ENCN (Incremental Enc.)

Bill of Materials

Pcs.	MPN	Value	Footprint	Description
4	MC0603F104M500CT	100nF	0603	Cap, Multicomp
2	GRM188R61E225KA12D	2u2	0603	Cap, Murata
1	MC0603X474K160CT	470nF	0603	Cap, Multicomp
1	MC0603B223K500CT	22nF	0603	Cap, Multicomp
2	GRM31CR61H106MA12L	10uF,50V,10%	1206	Cap, Murata
4	GCM188R71H224KA64D	220nF	0603	Cap, Murata
2	C1608X7R1H474K080AC	470nF, 50V	603	Cap, TDK
1	EEU-FR1H151B	150uF,50V,lowESR	THT	ELCO, Panasonic
1	LTST-C191TBKT-5A	20mA,2.8V,465nm	0603	LED, Lite-On
1	TMC5160-TA	TMC5160-TA	TQFP48-EP, 7x7	TRINAMIC
4	AO4882	AO4882	SOP-8L	FET, Alpha&Omega
1	MCWR06X000PTL	0R	0603	Res, Multicomp
8	MCWR06X22R0FTLV	22R, 100mW, 1%	0603	Res, Multicomp
4	MCSR06X47R0FTL	47R, 1%	0603	Res, Multicomp
2	ERJ-8BWF075V	0R075, 1W, 1%	1206	Res, Panasonic
1	MC0063W060312R2	2R2, 1%	0603	Res, Multicomp
1	MC0063W060311K	1k	0603	Res, Multicomp



BOB Schematics

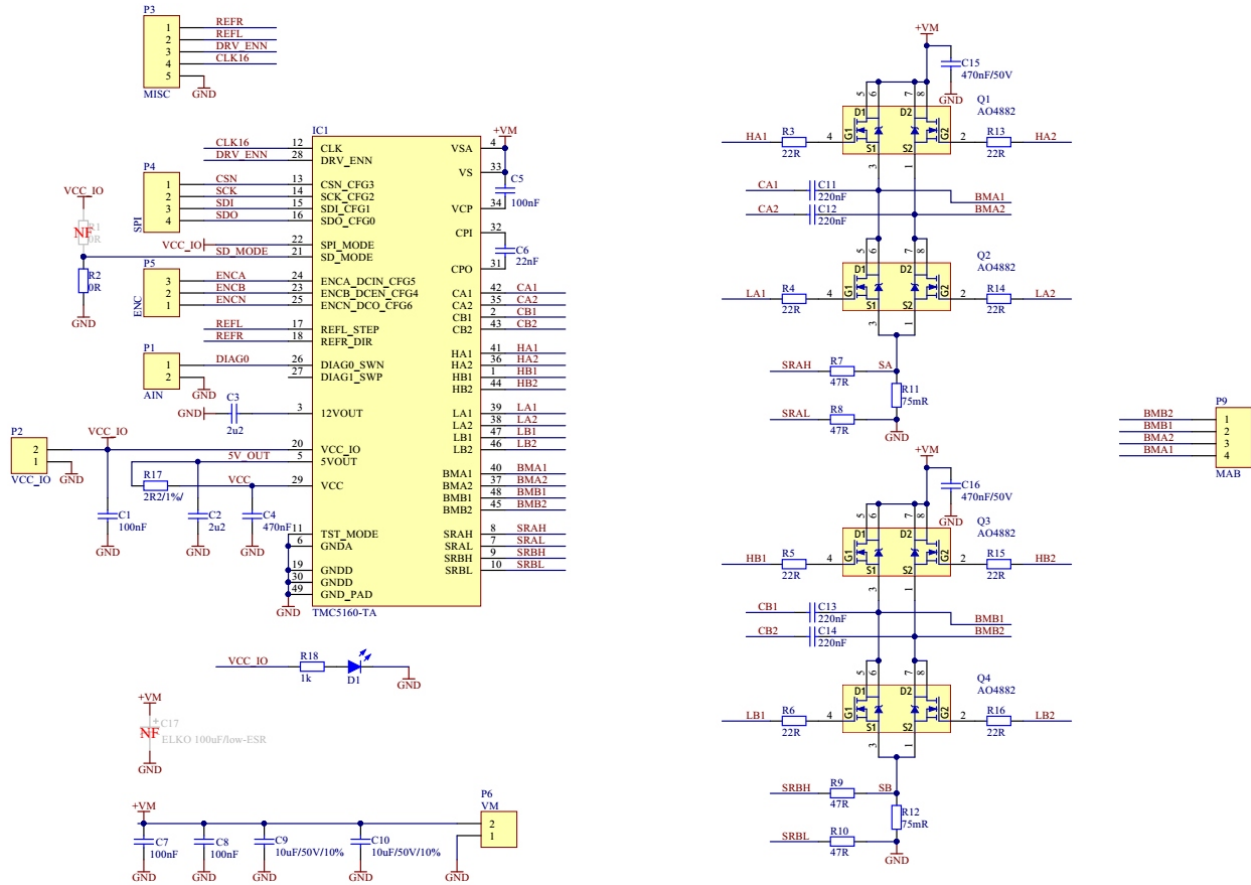

Mode Selection

- Soldering R2 / not R1 = Internal ramp generator active with Trinamic's 6-point-ramp (default mode)
- Soldering R1 / not R2 = Step/Direction interface active for use with external motion controller (STEP = REFL, DIR = REFR)

