



Chipsmall Limited consists of a professional team with an average of over 10 year of expertise in the distribution of electronic components. Based in Hongkong, we have already established firm and mutual-benefit business relationships with customers from,Europe,America and south Asia,supplying obsolete and hard-to-find components to meet their specific needs.

With the principle of “Quality Parts,Customers Priority,Honest Operation,and Considerate Service”,our business mainly focus on the distribution of electronic components. Line cards we deal with include Microchip,ALPS,ROHM,Xilinx,Pulse,ON,Everlight and Freescale. Main products comprise IC,Modules,Potentiometer,IC Socket,Relay,Connector.Our parts cover such applications as commercial,industrial, and automotives areas.

We are looking forward to setting up business relationship with you and hope to provide you with the best service and solution. Let us make a better world for our industry!



Contact us

Tel: +86-755-8981 8866 Fax: +86-755-8427 6832

Email & Skype: info@chipsmall.com Web: www.chipsmall.com

Address: A1208, Overseas Decoration Building, #122 Zhenhua RD., Futian, Shenzhen, China



Hardware Version V1.4

HARDWARE MANUAL

+



+

TMCM-1021

1-Axis Stepper
Controller / Driver
24V DC
up-to 0.7A RMS / 1.4A RMS
RS485 Interface
sens0step™ Encoder

+

+

UNIQUE FEATURES:

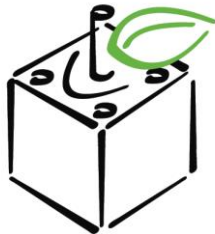

coolStep™

stallGuard²™

TRINAMIC Motion Control GmbH & Co. KG
Hamburg, Germany

www.trinamic.com



Table of Contents

1	Features.....	3
2	Order Codes	5
3	Mechanical and Electrical Interfacing.....	6
3.1	Size of Board	6
3.1.1	Board mounting considerations	6
3.2	Connectors.....	7
3.2.1	Power, Communication and I/O Connector	8
3.2.2	Motor Connector.....	13
4	Motor driver current	14
5	Reset to Factory Defaults.....	16
6	On-board LED.....	16
7	Operational Ratings	17
8	Functional Description.....	19
9	Life Support Policy.....	20
10	Revision History.....	21
10.1	Document Revision	21
10.2	Hardware Revisions	21
11	References	22

1 Features

The TMCM-1021 is a single axis controller/driver module for 2-phase bipolar stepper motors with state of the art feature set. It is highly integrated, offers a convenient handling and can be used in many decentralized applications. The module can be mounted on the back of NEMA11 (28mm flange size) and has been designed for coil currents up to 0.7A RMS (low current range, programmable) or 1.4A RMS (high current range, programmable, new additional range since hardware version 1.4) and 24V DC supply voltage. With its high energy efficiency from TRINAMIC's coolStep™ technology cost for power consumption is kept down. The TMCL™ firmware supports remote control (direct mode) and standalone operation (with TMCL program being executed on the TMCM-1021 itself).

MAIN CHARACTERISTICS

Highlights

- Motion profile calculation in real-time
- On the fly alteration of motor parameters (e.g. position, velocity, acceleration)
- High performance microcontroller for overall system control and serial communication protocol handling
- For position movement applications, where larger motors do not fit and higher torques are not required

Bipolar stepper motor driver

- Up to 256 microsteps per full step
- High-efficient operation, low power dissipation
- Dynamic current control
- Integrated protection
- stallGuard2 feature for stall detection
- coolStep feature for reduced power consumption and heat dissipation

Encoder

- sensOstep magnetic encoder (max. 1024 increments per rotation) e.g. for step-loss detection under all operating conditions and positioning supervision

Interfaces

- Up to 4 multi-purpose inputs (2 shared with general purpose outputs)
- 2 general purpose outputs
- RS485 2-wire communication interface

Software

- TMCL: standalone operation or remote controlled operation, program memory (non volatile) for up to 876 TMCL commands, and PC-based application development software TMCL-IDE available for free.

Electrical and mechanical data

- Supply voltage: +24V DC nominal (9... 28V DC max.)
- Motor current: up to 0.7A RMS (low current range, programmable) or 1.4A RMS (high current range, programmable, new additional range since hardware version 1.4)

Please refer to separate TMCL Firmware Manual, also.

TRINAMICS UNIQUE FEATURES – EASY TO USE WITH TMCL

stallGuard2™ stallGuard2 is a high-precision sensorless load measurement using the back EMF on the coils. It can be used for stall detection as well as other uses at loads below those which stall the motor. The stallGuard2 measurement value changes linearly over a wide range of load, velocity, and current settings. At maximum motor load, the value goes to zero or near to zero. This is the most energy-efficient point of operation for the motor.

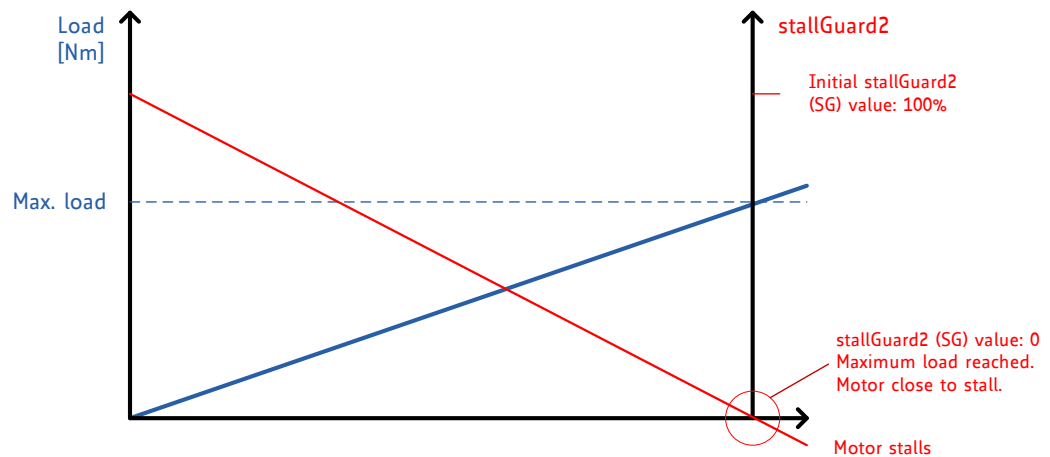

Figure 1.1 stallGuard2 load measurement SG as a function of load

coolStep™ coolStep is a load-adaptive automatic current scaling based on the load measurement via stallGuard2 adapting the required current to the load. Energy consumption can be reduced by as much as 75%. coolStep allows substantial energy savings, especially for motors which see varying loads or operate at a high duty cycle. Because a stepper motor application needs to work with a torque reserve of 30% to 50%, even a constant-load application allows significant energy savings because coolStep automatically enables torque reserve when required. Reducing power consumption keeps the system cooler, increases motor life, and allows reducing cost.

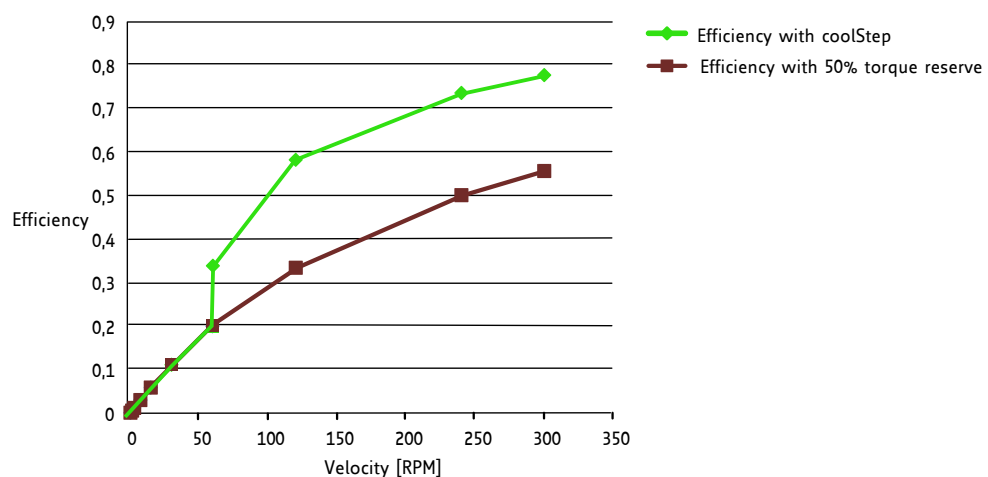

Figure 1.2 Energy efficiency example with coolStep

2 Order Codes

Order code	Description	Size of unit
TMCM-1021	Single axis bipolar stepper motor controller/driver electronics with integrated encoder electronics	28mm x 28mm

Table 2.1 Order codes

A cable loom set is available for this module:

Order code	Description
TMCM-1021-CABLE	Cable loom for TMCM-1021 <ul style="list-style-type: none">- 1x cable loom for power, communication and I/O connector (cable length approx. 200mm)- 1x cable loom for motor connector (cable length ca. 200mm)

Table 2.2 Cable loom order code

3 Mechanical and Electrical Interfacing

3.1 Size of Board

The board with the controller/driver electronics has an overall size of 28mm x 28mm in order to fit on the back side of a NEMA11 (28mm flange size) stepper motor. The printed circuit board outline is marked green in the following figure:

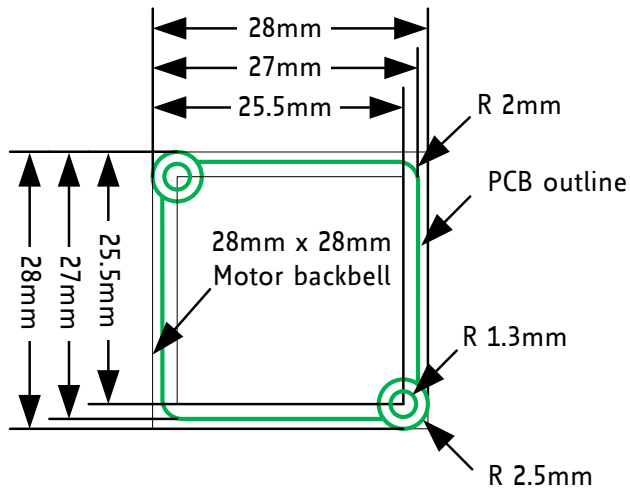

Figure 3.1 Board dimensions and position of mounting holes

Maximum board height (without mating connectors and cable looms) is about 10mm (approx. 6mm above printed circuit board level).

3.1.1 Board mounting considerations

The board offers two mounting holes for M2.5 screws (both holes with 2.6mm diameter). Both mounting holes are isolated. Nevertheless, it is highly recommended to electrically connect any metal screws used for mounting to supply ground (either directly or via resistor) in order to prevent any electrostatic discharge (ESD) across the isolation barrier. This is especially recommended in case the board is mounted to the backside of a motor.

Since hardware version 1.4 a second high current range for motor currents up-to 1.4A RMS is available. This makes it possible to support NEMA11 motors with typical standard coil currents up-to 0.7A RMS using the low current range and with the same hardware also NEMA17 bipolar stepper motors with coil currents up-to 1.4A RMS using the high current range.

Example for setup with TMC-1021_V14 mounted to back side of NEMA17 motor (with sensOstep™ encoder):

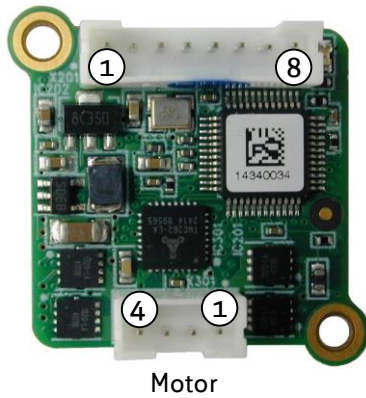

Figure 3.2: TMC-1021 V14 mounted to back side of NEMA17 bipolar stepper motor

3.2 Connectors

The TMCM-1021 has two connectors, an 8-pin power, communication and I/O (input/output) connector and a 4-pin motor connector (used to connect the attached motor).

Power / communication / I/Os



Motor

Figure 3.3 TMCM-1021 connectors

Overview of connector and mating connector types:

Label	Connector type	Mating connector types
Power, communication and I/O	CI0108P1VK0-LF CVIlux CI01 series, 8pins, 2mm pitch	Connector housing CVIlux: CI01085000-A Contacts CVIlux: CI01T011PE0-A <i>or</i> Connector housing JST: PHR-8 Contacts JST: SPH-002T-P0.5S Wire: 0.22mm ²
Motor	CI0104P1VK0-LF CVIlux CI01 series, 4 pins, 2mm pitch	Connector housing CVIlux: CI01045000-A Contacts CVIlux: CI01T011PE0-A <i>or</i> Connector housing JST: PHR-4 Contacts JST: SPH-002T-P0.5S Wire: 0.22mm ²

Table 3.1 Connectors and mating connectors, contacts and applicable wire

3.2.1 Power, Communication and I/O Connector

An 8-pin, 2mm pitch single row connector is used for power supply, RS485 serial communication and additional multi-purpose inputs and outputs.



Pin	Label	Direction	Description
1	GND	Power (GND)	GND
2	VDD	Power (Supply)	VDD, typ. +24V (+9V...+28V max.)
3	RS485+	Bidirectional	RS485 interface, diff. signal (non-inverting)
4	RS485-	Bidirectional	RS485 interface, diff. signal (inverting)
5	IN_0	Input	General purpose digital input, +24V compatible, internal 20k pull-down resistor
			Alternate function 1: Step input, +24V compatible, internal 20k pull-down resistor. <i>Please note: the bandwidth of the low-pass (noise rejection) filter at the input is 16kHz (-3dB) which will limit the upper step frequency</i>
			Alternate function 2: Left stop switch, +24V compatible, internal 20k pull-down resistor
6	IN_1	Input	General purpose digital input, +24V compatible, internal 20k pull-down resistor
			Alternate function 1: Direction input, +24V compatible, internal 20k pull-down resistor <i>Please note: the bandwidth of the low-pass (noise rejection) filter at the input is 16kHz (-3dB)</i>
			Alternate function 2: Right stop switch, +24V compatible, internal 20k pull-down resistor
7	OUT_0 / IN_2	Output / Input	Open drain output with freewheeling diode (max. 100mA) <i>Please note: there is a 20k pull-down resistor of the input connected in parallel</i>
			Alternate function 1: general purpose digital input, +24V compatible, internal 20k pull-down resistor
			Alternate function 2: home switch, +24V compatible, internal 20k pull-down resistor
8	OUT_1 / IN_3	Output / Input	Open drain output with freewheeling diode (max. 100mA) <i>Please note: there is a 20k pull-down resistor of the input connected in parallel</i>
			Alternate function 1: digital input, +24V compatible, internal 20k pull-down resistor
			Alternate function 2: analog input, 0..6.6V range, +24V survival, internal 20k pull-down resistor

Table 3.2 8pin power, communication and I/O connector

3.2.1.1 Power supply

For proper operation care has to be taken with regard to power supply concept and design. Due to space restrictions the TMCM-1021 includes just about 20µF/35V (V1.2) resp. 30µF/35V (V1.4) of supply filter capacitors. These are ceramic capacitors which have been selected for high reliability and long life time. The module includes a 24V suppressor diode for over-voltage protection.

Please take the following measures into account in order to avoid serious damage of the device:

	<p>Add external power supply capacitors!</p> <p>It is recommended to connect an electrolytic capacitor of significant size (e.g. 470µF/35V) to the power supply lines next to the TMCM-1021!</p> <p>Rule of thumb for size of electrolytic capacitor: $c = 1000 \frac{\mu F}{A} \times I_{SUPPLY}$</p> <p>In addition to power stabilization (buffer) and filtering this added capacitor will also reduce any voltage spikes which might otherwise occur from a combination of high inductance power supply wires and the ceramic capacitors. In addition it will limit slew-rate of power supply voltage at the module. The low ESR of ceramic-only filter capacitors may cause stability problems with some switching power supplies.</p>
	<p>Keep the power supply voltage below the upper limit of 28V!</p> <p>Otherwise the driver electronics will seriously be damaged! Especially, when the selected operating voltage is near the upper limit a regulated power supply is highly recommended. Please see also chapter 7, operating values.</p>
	<p>There is no reverse polarity protection!</p> <p>The module will short any reversed supply voltage due to internal diodes of the driver transistors.</p>

3.2.1.2 RS485

For remote control and communication with a host system the TMCM-1021 provides a two wire RS485 bus interface. For proper operation the following items should be taken into account when setting up an RS485 network:

1. **BUS STRUCTURE:**

The network topology should follow a bus structure as closely as possible. That is, the connection between each node and the bus itself should be as short as possible. Basically, it should be short compared to the length of the bus.

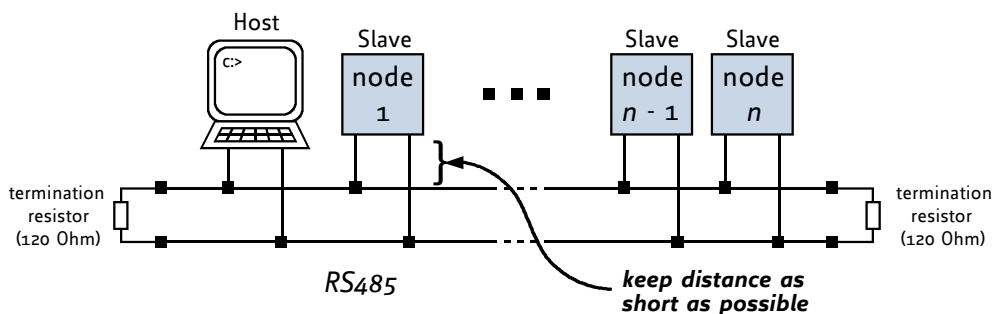

Figure 3.4: Bus structure

2. **BUS TERMINATION:**

Especially for longer busses and/or multiple nodes connected to the bus and/or high communication speeds, the bus should be properly terminated at both ends. The TMCM-1021 does not integrate any termination resistor. Therefore, 120 Ohm termination resistors at both ends of the bus have to be added externally.

3. **NUMBER OF NODES:**

The RS485 electrical interface standard (EIA-485) allows up to 32 nodes to be connected to a single bus. The bus transceivers used on the TMCM-1021 units (hardware V1.2: SN65HVD3082ED, since hardware V1.4: SN65HVD1781D) have a significantly reduced bus load and allow a maximum of 255 units to be connected to a single RS485 bus using TMCL firmware. *Please note: usually it cannot be expected to get reliable communication with the maximum number of nodes connected to one bus and maximum supported communication speed at the same time. Instead, a compromise has to be found between bus cable length, communication speed and number of nodes.*

4. **COMMUNICATION SPEED:**

The maximum RS485 communication speed supported by the TMCM-1021 is 115200 bit/s (FW version 1.29 with TMCM-1021 hardware version 1.2 and 1.4). Factory default is 9600 bit/s. *Please see separate TMCM-1021 TMCL firmware manual for information regarding other possible communication speeds below 115200 bit/s.*

5. **NO FLOATING BUS LINES:**

Avoid floating bus lines while neither the host/master nor one of the slaves along the bus line is transmitting data (all bus nodes switched to receive mode). Floating bus lines may lead to communication errors. In order to ensure valid signals on the bus it is recommended to use a resistor network connecting both bus lines to well defined logic levels.

There are actually two options which can be recommended:

Add resistor (Bias) network on **one** side of the bus, only (120R termination resistor still at **both** ends):

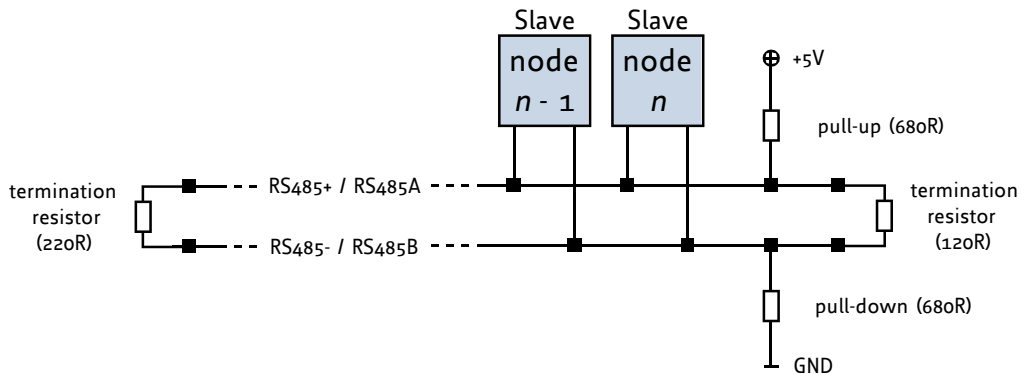

Figure 3.5: Bus lines with resistor (Bias) network on one side, only

Or add resistor (Bias) network at **both** ends of the bus (like Profibus™ termination):

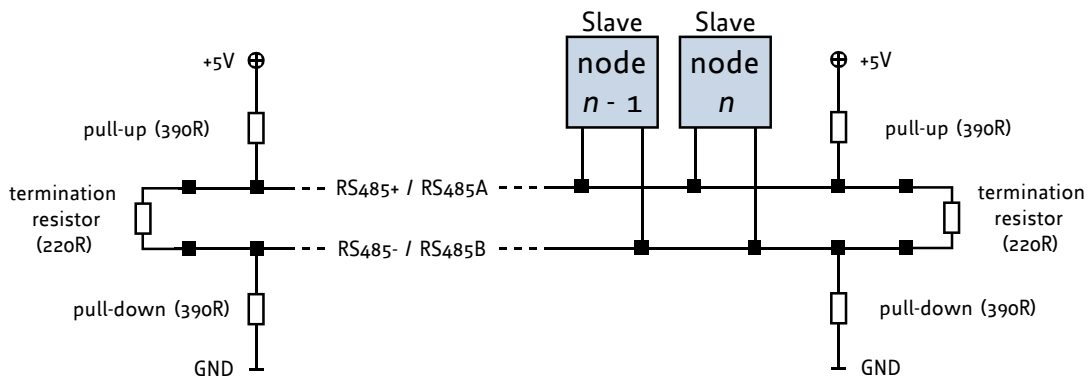

Figure 3.6: Bus lines with resistor (Bias) network at both ends

Certain RS485 interface converters available for PCs already include these additional resistors (e.g. USB-2-485 with bias network at one end of the bus).

3.2.1.3 Digital Inputs IN_0 and IN_1

The eight pin connector of the TMCM-1021 provides four general purpose inputs IN_0, IN_1, IN_2 and IN_3. The first two inputs have dedicated connector pins while the other two share pins with two general purpose outputs.

All four inputs are protected using voltage resistor dividers together with limiting diodes against voltages below 0V (GND) and above +3.3V DC. Input circuit of the first two inputs IN_0 and IN_1 is shown below:

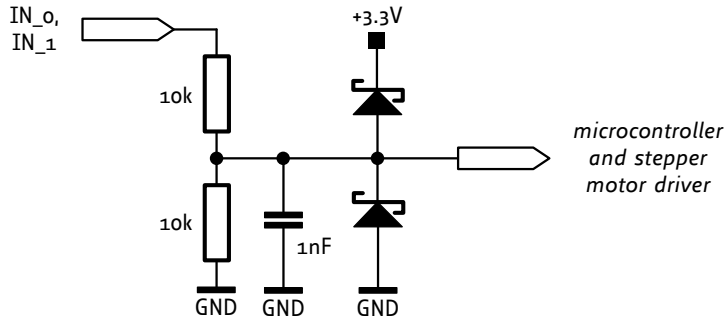

Figure 3.7 General purpose inputs IN_0 and IN_1

The two inputs have alternate functions depending on configuration in software. The following functions are available:

Label (connector pin)	Default Function	Alternate function 1	Alternate function 2
IN_0 (5)	Digital input <i>+24V compatible, internal 20k pull-down resistor</i>	Step signal input (connected to stepper motor driver step input) <i>+24V compatible, internal 20k pull-down resistor.</i> <i>Please note: the bandwidth of the low-pass RC (10k / 1nF) filter at the input is 16kHz (-3dB) which will limit the upper step frequency</i>	Left stop switch <i>+24V compatible, internal 20k pull-down resistor</i>
IN_1 (6)	Digital input <i>+24V compatible, internal 20k pull-down resistor</i>	Direction signal input (connected to stepper motor driver direction input) <i>+24V compatible, internal 20k pull-down resistor.</i> <i>Please note: the bandwidth of the low-pass RC (10k / 1nF) filter at the input is 16kHz (-3dB)</i>	Right stop switch <i>+24V compatible, internal 20k pull-down resistor</i>

Table 3.3 Multipurpose inputs / alternate functions

All four inputs are connected to the on-board processor and can be used as general purpose digital inputs.

Using the alternate function 1 of IN_0 and IN_1 it is possible to control the on-board stepper motor driver with the help of an external stepper motor controller using step and direction signals (Please see separate TMCL firmware manual / axis parameter 254 for more details how to enable this mode). For the step and

direction signals the signal levels are the same as for the general purpose digital inputs. Please note that the low-pass filter (for noise rejection) at the inputs offers a bandwidth of 16kHz (-3dB).

IN_3 can be used as analog input, also. A 12bit analog to digital converter integrated in the microcontroller will convert any analog input voltage between 0 and +6.6V to a digital value between 0 and 4095 then.

3.2.1.4 Inputs IN_2, IN_3, Digital Outputs OUT_0, OUT_1

The eight pin connector of the TMCM-1021 provides two general purpose outputs. These two outputs are open-drain outputs and can sink up to 100mA each. Both outputs OUT_0 and OUT_1 share pins with two of the four inputs (IN_2 resp. IN_3).

The inputs are protected using voltage resistor dividers together with limiting diodes against voltages below 0V (GND) and above +3.3V DC. The circuit of the two outputs and the two inputs connected in parallel to the inputs is shown below:

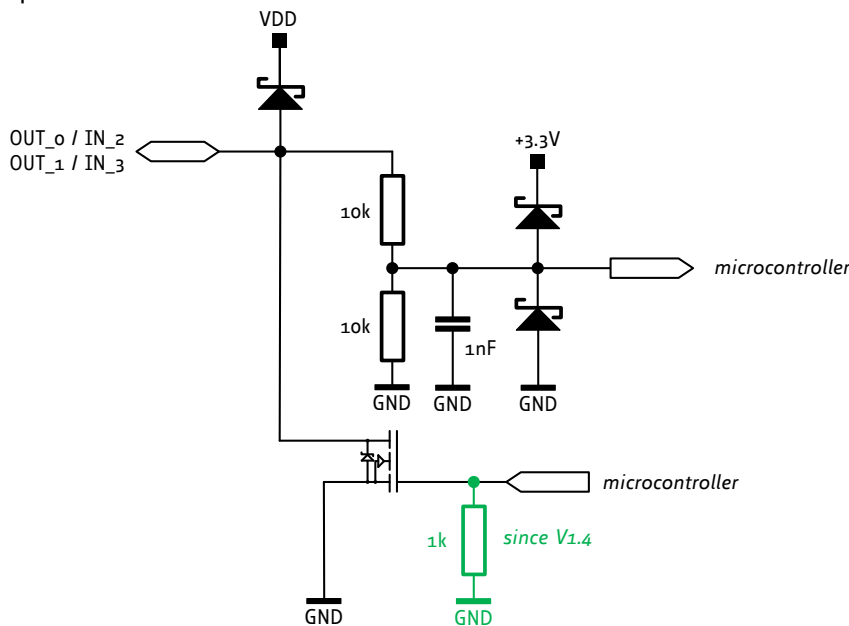

Figure 3.8 General purpose outputs OUT_0, OUT_1 and inputs IN_2, IN_3 connected in parallel

The outputs of the N-channel MOSFET transistors (Open-Drain) are connected to freewheeling diodes each for protection against voltage spikes especially from inductive loads (relais etc.). Please take into account the 20k (2x 10k in series) resistance to ground (transistor not active) of the input voltage divider (figure 4.8) when designing the external "load" circuit.



Since hardware version 1.4 the gate inputs of the MOSFETs are pulled-low during power-up and while the processor might be still in reset / output pins not initialized. This way, the outputs will not briefly switch on at power-up.

The two outputs OUT_0 / OUT_1 and inputs IN_2 / IN_3 have alternate functions depending on configuration in software:

Label (connector pin)	Default Function	Alternate function 1	Alternate function 2
OUT_0 / IN_2 (7)	Open drain output with freewheeling diode (max. 100mA) <i>Please note: there is a 20k pull-down resistor of the input connected in parallel</i>	Alternate function 1: general purpose digital input, +24V compatible, internal 20k pull-down resistor	Alternate function 2: home switch, +24V compatible, internal 20k pull-down resistor

Label (connector pin)	Default Function	Alternate function 1	Alternate function 2
OUT_1 / IN_3 (8)	Open drain output with freewheeling diode (max. 100mA) <i>Please note: there is a 20k pull-down resistor of the input connected in parallel</i>	Alternate function 1: digital input, +24V compatible, internal 20k pull-down resistor	Alternate function 2: analog input, 0..6.6V range, +24V survival, internal 20k pull-down resistor

Table 3.4 Multipurpose outputs / inputs / alternate functions



	Do not apply any voltage above supply voltage to inputs IN_2 and IN_3. Due to the freewheeling diodes of the outputs connected in parallel they will be shorted to power supply input voltage.
	For hardware version 1.2: Do not connect either IN_2 or IN_3 directly to a low resistance supply voltage (e.g. directly to any power supply voltage). As the output transistors connected in parallel might briefly switch-on during power-up they might be damaged / destroyed if the current through the transistors to ground exceeds 100mA.

3.2.2 Motor Connector

A 4-pin, 2mm pitch single row connector is used for connecting the four motor wires to the electronics.

Pin	Label	Direction	Description
1	OB2	Output	Pin 2 of motor coil B
2	OB1	Output	Pin 1 of motor coil B
3	OA2	Output	Pin 2 of motor coil A
4	OA1	Output	Pin 1 of motor coil A

Table 3.4 Motor connector

	Do not connect or disconnect motor during operation! Motor cable and motor inductivity might lead to voltage spikes when the motor is disconnected / connected while energized. These voltage spikes might exceed voltage limits of the driver MOSFETs and might permanently damage them. Therefore, always disconnect power supply before connecting / disconnecting the motor.
	For hardware version 1.4: please note the additional high current range for motor currents up-to 1.4A RMS! Setting motor current too high might lead to excessive power dissipation inside the motor, overheating and even permanent damage of the motor. Therefore, make sure the motor current is properly set. Also with hardware version 1.2 the low current range is set as default.

Example for connecting a motor.

TMCM-1021	QSH2818 Motor		
Motor connector pin	Cable colour	Coil	Description
1	Blue	B-	Motor coil B pin 2
2	Red	B	Motor coil B pin 1
3	Green	A-	Motor coil A pin 2
4	Black	A	Motor coil A pin 1

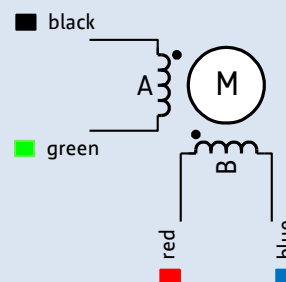

4 Motor driver current

The on-board stepper motor driver operates current controlled. The driver current may be programmed in software in two ranges (low current range up-to 0.7A RMS and high current range up-to 1.4A RMS) with 32 effective scaling steps in hardware for each range. *Please note: the high current range is available with hardware revision V1.4, only – not with hardware revision V1.2!*

Explanation of different columns in table below:

Motor current setting in software (TMCL) These are the values for TMCL axis parameter 6 (motor run current) and 7 (motor standby current). They are used to set the run / standby current using the following TMCL commands:

SAP 6, 0, <value> // set run current

SAP 7, 0, <value> // set standby current

(read-out value with GAP instead of SAP. Please see separate TMCM-1021 firmware manual for further information)

Range setting in software (TMCL) This is the value for TMCL axis parameter 179 (Vsense). This value defines the current range. This value can be set using the following TMCL command:

SAP 179, 0, <value> // = 0 high current range
// = 1 low current range

For <value> either 0 (high current range) or 1 (low current range) is supported (see table) since hardware revision V1.4. For earlier hardware revisions (incl. V1.2) this parameter is set to the fixed value "1" (low current range).

(read-out value with GAP instead of SAP. Please see separate TMCM-1021 firmware manual for further information)

Motor current I_{RMS} [A] Resulting motor current based on range and motor current setting

Motor current setting in software (TMCL)	Range setting in software (TMCL)	Current scaling step (CS)	Motor current I_{COIL_PEAK} [A]	Motor current I_{COIL_RMS} [A]
0..7	1	0	0.034	0.024
8..15	1	1	0.069	0.049
16..23	1	2	0.103	0.073
24..31	1	3	0.138	0.097
32..39	1	4	0.172	0.122
40..47	1	5	0.206	0.146
48..55	1	6	0.241	0.170
56..63	1	7	0.275	0.194
64..71	1	8	0.309	0.219
72..79	1	9	0.344	0.243
80..87	1	10	0.378	0.267
88..95	1	11	0.413	0.292
96..103	1	12	0.447	0.316
104..111	1	13	0.481	0.340
112..119	1	14	0.516	0.365
120..127	1	15	0.550	0.389
128..135	1	16	0.584	0.413
136..143	1	17	0.619	0.438

Motor current setting in software (TMCL)	Range setting in software (TMCL)	Current scaling step (CS)	Motor current I_{COIL_PEAK} [A]	Motor current I_{COIL_RMS} [A]
144..151	1	18	0.653	0.462
152..159	1	19	0.688	0.486
160..167	1	20	0.722	0.510
168..175	1	21	0.756	0.535
176..183	1	22	0.791	0.559
184..191	1	23	0.825	0.583
192..199	1	24	0.859	0.608
200..207	1	25	0.894	0.632
208..215	1	26	0.928	0.656
216..223	1	27	0.963	0.681
224..231	1	28	0.997	0.705
232..239	1	29	1.031	0.729
240..247	1	30	1.066	0.754
248..255	1	31	1.100	0.778
0..7	0	0	0.064	0.045
8..15	0	1	0.127	0.090
16..23	0	2	0.191	0.135
24..31	0	3	0.254	0.180
32..39	0	4	0.318	0.225
40..47	0	5	0.381	0.270
48..55	0	6	0.445	0.315
56..63	0	7	0.508	0.359
64..71	0	8	0.572	0.404
72..79	0	9	0.635	0.449
80..87	0	10	0.699	0.494
88..95	0	11	0.763	0.539
96..103	0	12	0.826	0.584
104..111	0	13	0.890	0.629
112..119	0	14	0.953	0.674
120..127	0	15	1.017	0.719
128..135	0	16	1.080	0.764
136..143	0	17	1.144	0.809
144..151	0	18	1.207	0.854
152..159	0	19	1.271	0.899
160..167	0	20	1.334	0.944
168..175	0	21	1.398	0.988
176..183	0	22	1.461	1.033
184..191	0	23	1.525	1.078
192..199	0	24	1.589	1.123
200..207	0	25	1.652	1.168
208..215	0	26	1.716	1.213
216..223	0	27	1.779	1.258
224..231	0	28	1.843	1.303
232..239	0	29	1.906	1.348
240..247	0	30	1.970	1.393
248..255	0	31	2.033	1.438

In addition to the settings in the table the motor current may be switched off completely (free-wheeling) using axis parameter 204 (see TMC1021 firmware manual).

5 Reset to Factory Defaults

It is possible to reset the TMC1021 to factory default settings without establishing a communication link. This might be helpful in case communication parameters of the preferred interface have been set to unknown values or got accidentally lost.

For this procedure two pads on the bottom side of the board have to be shorted (see Figure 5.1).

Please perform the following steps:

1. Power supply off and USB cable disconnected
2. Short two pads as marked in Figure 5.1
3. Power up board (power via USB is sufficient for this purpose)
4. Wait until the on-board red and green LEDs start flashing fast (this might take a while)
5. Power-off board (disconnect USB cable)
6. Remove short between pads
7. After switching on power-supply / connecting USB cable all permanent settings have been restored to factory defaults

Short these two PADS on
the bottom of the PCB

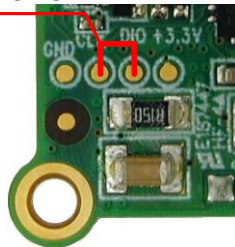

Figure 5.1 Reset to factory default settings

6 On-board LED

The board offers one LED in order to indicate board status. The function of the LED is dependent on the firmware version. With standard TMCL firmware the green LED flashes slowly during operation.

When there is no valid firmware programmed into the board or during firmware update the green LED is permanently on.

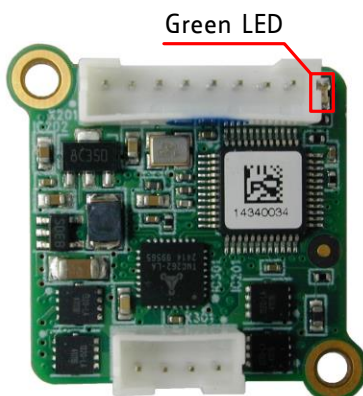

Figure 6.1 On-board LED

7 Operational Ratings

The operational ratings show the intended or the characteristic ranges and should be used as design values.

In no case shall the maximum values be exceeded!

Symbol	Parameter	Min	Typ	Max	Unit
VDD	Power supply voltage for operation	9	12... 24	28	V
I _{COIL_PEAK_L}	Motor coil current for sine wave peak (low range setting, chopper regulated, adjustable via software)	0		1	A
I _{COIL_RMS_L}	Continuous motor current (RMS) (low current range setting, chopper regulated, adjustable via software)	0		0.7	A
I _{COIL_PEAK_H*})	Motor coil current for sine wave peak (high current range setting, chopper regulated, adjustable via software)	0		2*)	A
I _{COIL_RMS_H*})	Continuous motor current (RMS) (high current range setting, chopper regulated, adjustable via software)	0		1.4*)	A
I _{DD}	Power supply current		<< I _{COIL}	1.4 * I _{COIL}	A
T _{ENV}	Environment temperature at rated current (no forced cooling required)	-35		+60	°C

Table 7.1 General operational ratings of module

*) High current range available as new additional range with hardware revision V1.4 – **not** with hardware revision V1.2

Symbol	Parameter	Min	Typ	Max	Unit
V _{OUT_0/1}	Voltage at open collector output	0		+VDD	V
I _{OUT_0/1}	Output sink current			100	mA
V _{IN_digital 0/1/2/3}	Input voltage for IN_0, IN_1, IN_2, IN_3 when used as digital input	0		+VDD	V
V _{IN_digital_L 0/1/2/3}	Low level voltage for IN_0, IN_1, IN_2 and IN_3 when used as digital input	0		1.2	V
V _{IN_digital_H 0/1/2/3}	High level voltage for IN_0, IN_1, IN_2 and IN_3 when used as digital input	4		+VDD	V
V _{IN_analog 3}	Measurement range for IN_3 when used as analog input	0		+6.6	V

Table 7.2 Operational ratings of multi-purpose I/Os

Symbol	Parameter	Min	Typ	Max	Unit
N_{RS485}	Number of nodes connected to single RS485 network			255	
f_{RS485}	Maximum bit rate supported on RS485 connection		9600	115200	bit/s

Table 7.3 Operational ratings of RS485 interface

8 Functional Description

The TCM-1021 is a highly integrated controller/driver module which can be controlled via RS485 interface. Communication traffic is kept low since all time critical operations (e.g. ramp calculations) are performed on board. The nominal supply voltage of the unit is 24V DC. The module is designed for both, standalone operation and direct mode. Full remote control of device with feedback is possible. The firmware of the module can be updated via the serial interface.

In Figure 8.1 the main parts of the module are shown:

- the microprocessor, which runs the TMCL operating system (connected to TMCL memory),
- the power driver with its energy efficient coolStep feature,
- the MOSFET driver stage, and
- the sensOstep encoder with resolutions of 10bit (1024 steps) per revolution.

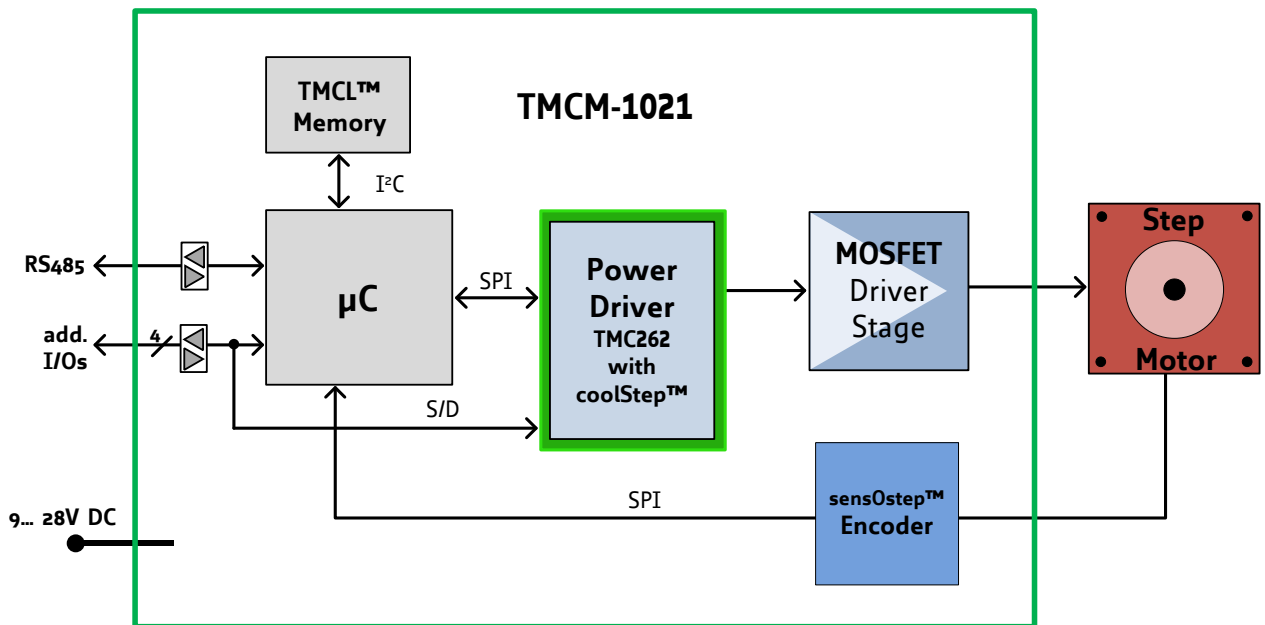

Figure 8.1 Main parts of TCM-1021

The TCM-1021 comes with the PC based software development environment TMCL-IDE for the Trinamic Motion Control Language (TMCL). Using predefined TMCL high level commands like *move to position* a rapid and fast development of motion control applications is guaranteed. Please refer to the TCM-1021 Firmware Manual for more information about TMCL commands.

9 Life Support Policy

TRINAMIC Motion Control GmbH & Co. KG does not authorize or warrant any of its products for use in life support systems, without the specific written consent of TRINAMIC Motion Control GmbH & Co. KG.

Life support systems are equipment intended to support or sustain life, and whose failure to perform, when properly used in accordance with instructions provided, can be reasonably expected to result in personal injury or death.

© TRINAMIC Motion Control GmbH & Co. KG 2013 - 2018

Information given in this data sheet is believed to be accurate and reliable. However neither responsibility is assumed for the consequences of its use nor for any infringement of patents or other rights of third parties, which may result from its use.

Specifications are subject to change without notice.

All trademarks used are property of their respective owners.



10 Revision History

10.1 Document Revision

Version	Date	Author	Description
0.90	2011-AUG-02	GE	- Initial version
0.91	2011-AUG-25	SD	- Information about left, right, and home switch added. - Minor changes
0.92	2011-NOV-10	GE	- Motor connector corrected and motor connection added - General purpose output circuit extended - Hardware revision list updated
1.00	2012-MAR-09	SD	- Rule of thumb for capacitor added. - Design updated - Chapter 6 (on-board LED) new - Chapter 4 (reset to factory defaults) new
1.01	2012-MAY-20	SD	- Minor changes
1.02	2013-JUL-23	SD	- Connector types updated. - Chapter Fehler! Verweisquelle konnte nicht gefunden werden. updated.
1.03	2014-SEP-30	GE	- Information regarding new hardware version 1.4 added - Several corrections and clarifications included
1.04	2018-JAN-22	GE	- Pin reference for inputs and outputs on page 11-13 corrected

Table 10.1 Document revision

10.2 Hardware Revisions

Version	Date	Description / Modifications compared to previous versions
TMC1021_V10*)	2011-JUL-11	Initial version
TMC1021_V11*)	2011-AUG-18	- TMC262 clock generation switched to internal clock - Encoder circuit corrected - LED added
TMC1021_V12**)	2011-SEP-28	- LED moved to location near 8pin connector (version 1.2 is 100% firmware compatible with V1.1)
TMC1021_V13*)	2013-MAY-14	- MOSFETs: The new driver stage is more powerful (less heat dissipation) than the one used on V1.2. The module now supports two motor current ranges (up-to 0.7A RMS (same as V1.2 – fully compatible also with respect to current scaling) and up-to 1.4A RMS motor current (new with version 1.4)). Switching between these two ranges can be done in software (lower current range: SAP 179, 0, 1 (default), higher current range: SAP 179, 0, 0). The lower current range (up-to 0.7A RMS / SAP 179, 0, 1) is the default one in order to maintain 100% compatibility in terms of motor current settings. For the lower current range the motor current can be scaled down using TMCL command SAP 6, 0, 0 ... 255 as known from the current version. Same settings will result in same motor current values as with current version. After switching to the higher current range (SAP 179, 0, 0) similar scaling is possible with the high current range, also. Due to the extended current settings the module supports NEMA11 (28mm) bipolar stepper motors using the lower current range and also NEMA17 (42mm) bipolar stepper motors using the higher current range – making it possible to use just one module type in a

Version	Date	Description / Modifications compared to previous versions
		<p>mixed NEMA11 / NEMA17 system environment (if desired / applicable).</p> <ul style="list-style-type: none"> - RS485 transceiver: the RS485 transceiver has been replaced with the SN65HVD1781 transceiver offering better fault protection (up to 70V fault protection) and supporting more nodes in one network (up-to 255 nodes per network with TMCL firmware). The supply voltage of the transceiver IC has been reduced to +3.3V (supported by the transceiver IC) in order to reduce power consumption. - General purpose outputs OUT0 / OUT1: the driver circuit of the open-drain output MOSFETs has been modified in order to ensure glitch-free power-up. That is, output MOSFETs will not turn briefly on while processor still in reset / not initialized. - Processor speed: the processor crystal has been changed to 16MHz
TMC1021_V14	2013-JUL-30	<ul style="list-style-type: none"> - On-board voltage regulator design has been improved in order to allow processor core frequencies of 32MHz (previously 16MHz and 8MHz depending on firmware version)

*) V10, V11 and V13: prototypes only.

**) V12: series product version. Is replaced with V14 series product version due to EOL (end-of-life) of the driver MOSFETs. Please see "PCN_1012_10_22_TMC1021.pdf" on our Web-site, also

Table 10.2 Hardware revision

11 References

[TMC1021]	TMC1021 TMCL Firmware Manual
[QSH2818-32-07-006]	NEMA11 / 28mm bipolar stepper motor
[QSH2818-51-07-012]	NEMA11 / 28mm bipolar stepper motor
[USB-2-485]	USB-2-485 interface converter

TRINAMIC manuals are available on <http://www.trinamic.com>.