



Chipsmall Limited consists of a professional team with an average of over 10 year of expertise in the distribution of electronic components. Based in Hongkong, we have already established firm and mutual-benefit business relationships with customers from,Europe,America and south Asia,supplying obsolete and hard-to-find components to meet their specific needs.

With the principle of “Quality Parts,Customers Priority,Honest Operation,and Considerate Service”,our business mainly focus on the distribution of electronic components. Line cards we deal with include Microchip,ALPS,ROHM,Xilinx,Pulse,ON,Everlight and Freescale. Main products comprise IC,Modules,Potentiometer,IC Socket,Relay,Connector.Our parts cover such applications as commercial,industrial, and automotives areas.

We are looking forward to setting up business relationship with you and hope to provide you with the best service and solution. Let us make a better world for our industry!



Contact us

Tel: +86-755-8981 8866 Fax: +86-755-8427 6832

Email & Skype: info@chipsmall.com Web: www.chipsmall.com

Address: A1208, Overseas Decoration Building, #122 Zhenhua RD., Futian, Shenzhen, China



Hardware Version V 1.10

HARDWARE MANUAL



TMCM-1613

Single Axis BLDC
Controller / Driver
Block-commutation
Hall-sensor based
Analog+digital inputs / outputs
Up-to 500W / 24V DC
Opt. USB dongle for programming



TMCM-1613-REC

Single Axis BLDC
Controller / Driver
Block-commutation
Hall-sensor based
Analog+digital inputs / outputs
Up-to 500W / 24V DC
*Active rectifier add-on for
DC-motor emulation*
Opt. USB dongle for programming

TRINAMIC Motion Control GmbH & Co. KG
Hamburg, Germany

www.trinamic.com



TRINAMIC
MOTION CONTROL

Table of contents

1	Life support policy	3
2	Features	4
3	Order codes	5
4	Mechanical and Electrical Interfacing	6
4.1	Dimensions and Mounting Holes	6
4.2	Board mounting considerations.....	6
5	Connectors of TMCM-1613 / TMCM-1613-REC	7
5.1	TMCM-1613 Power supply connection	8
5.2	TMCM-1613-REC Power supply connection	9
5.3	BLDC motor connection.....	10
5.4	VIN+ DETECT (TMCM-1613 only).....	10
5.5	Hall sensor connector (TMCM-1613 and TMCM-1613-REC)	10
5.6	I/O connector (TMCM-1613 and TMCM-1613-REC).....	10
5.6.1	Digital inputs	11
5.6.2	Analog input	12
5.6.3	Digital Output	12
5.6.4	Serial communication.....	13
6	On-board LEDs.....	15
7	Operational ratings	16
8	Functional Description	17
9	Revision History	18
9.1	Document revision	18
9.2	Hardware revision	18
10	References.....	19

1 Life support policy

TRINAMIC Motion Control GmbH & Co. KG does not authorize or warrant any of its products for use in life support systems, without the specific written consent of TRINAMIC Motion Control GmbH & Co. KG.

Life support systems are equipment intended to support or sustain life, and whose failure to perform, when properly used in accordance with instructions provided, can be reasonably expected to result in personal injury or death.

© TRINAMIC Motion Control GmbH & Co. KG 2015, 2016, 2017

Information given in this data sheet is believed to be accurate and reliable. However neither responsibility is assumed for the consequences of its use nor for any infringement of patents or other rights of third parties, which may result from its use.

Specifications are subject to change without notice.



2 Features

The TMCM-1613 is a single axis controller/driver module for 2-phase brushless DC motors (BLDC). It supports hall-sensor based block-commutation for supply voltages of up-to nom. 24V DC and electrical power of up-to 500W. It offers one analog input and two optically isolated digital inputs for easy application integration. Key parameters and different operation modes can be configured using an optional isolated USB communication interface dongle. Together with an optional rectifier add-on board DC motor emulation is possible with supply voltage level defining motor speed and polarity defining motor direction.

MAIN CHARACTERISTICS

Motor type

- Block commutated 3 phase BLDC motors with hall sensors
- Motor power up-to 500W
- 7V ... 24V nominal supply voltage

Highlights

- High-efficiency operation, low power-dissipation
- Lower supply voltage limit: 7V
- DC motor emulation with optional add-on rectifier board (part of TMCM-1613-REC)
- Open-frame enclosure
- Supports the TRINAMIC TMCL protocol and the TMCL software environment for parameterizing (with optional TMCM-1613-USB dongle)

Interfaces

- 2x digital inputs, 24V, optically-isolated (can be configured as high-side or low-side switch inputs)
- 1x analog input (0..10V)
- 1x digital (open-drain) output (pin-sharing with analog input)
- Optional communication interface via digital input and output

Software

- Via TMCM-1613-USB-Dongle: TMCL™ remote (direct mode). Fully supported by TMCL-IDE (PC based integrated development environment) incl. firmware updates

Mechanical data

- Size of the unit: 76mm x 70mm, overall height 25mm max. (valid for the TMCM-1613 and TMCM-1613-REC)
- 4x M4 mounting holes

Please see separate TMCM-1613 Software / Firmware documentation for additional information regarding operation modes and programming using the optional TMCM-1613-USB dongle.

3 Order codes

The TMC-1613 BLDC unit and its optional components are available as:

Order code	Description	Size of unit
TMC-1613	BLDC module, 24V, 500W, open-frame	76mm x 70mm x 25mm
TMC-1613-REC	BLDC module, 24V, 500W, open frame with rectifier add-on board for DC-motor emulation	76mm x 70mm x 25mm
TMC-1613-USB	USB communication interface dongle (isolated)	59mm x 33mm x 16mm

Table 3.1: TMC-1613 order code

A cable loom set is available for this module, also:

Order code	Description
TMC-1613-CABLE	Cable loom for TMC-1613. Contains (see chapter 5, also): <ul style="list-style-type: none"> - 1x cable loom for hall sensor connector - 1x cable loom for I/O connector

Table 3.2: TMC-1613 Cable loom order code

Please note: in contrast to some pictures in this manual mating screws for electrical connections (power supply and motor phases) are delivered pre-installed with the module and therefore, are not part of the Cable loom (TMC-1613-CABLE).

4 Mechanical and Electrical Interfacing

4.1 Dimensions and Mounting Holes

The dimensions of the controller/driver unit are approx. 76mm x 70mm x 25mm. There are four mounting holes for M4 screws (4.2mm diameter).

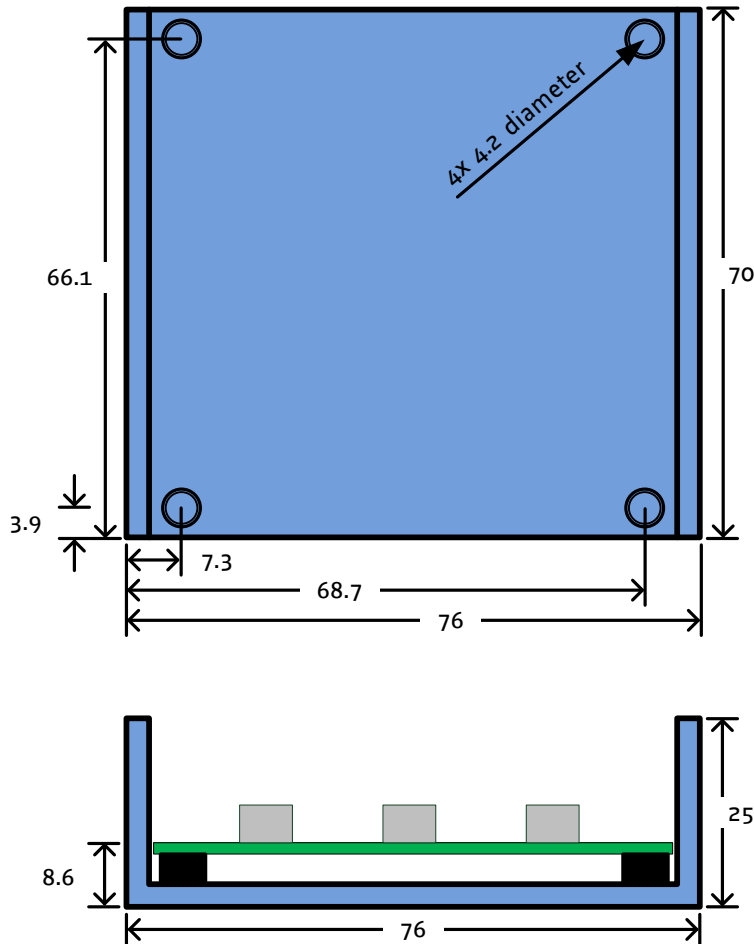

Figure 4.1 Dimensions of TCM-1613 and position of mounting holes

4.2 Board mounting considerations

The TCM-1613 unit offers four mounting holes for M4 screws (4.2mm diameter). The length of the screws should be at least 8.6mm. The unit should be mounted to a flat surface. Any heat conducting material – e.g. a metal plate is preferred.

While all four mounting holes are electrically isolated supply ground of the TCM-1613 is connected to the U-profile frame via a combination of $1M \parallel 10nF$ (500V) resistor + capacitor parallel combination.

5 Connectors of TMCM-1613 / TMCM-1613-REC

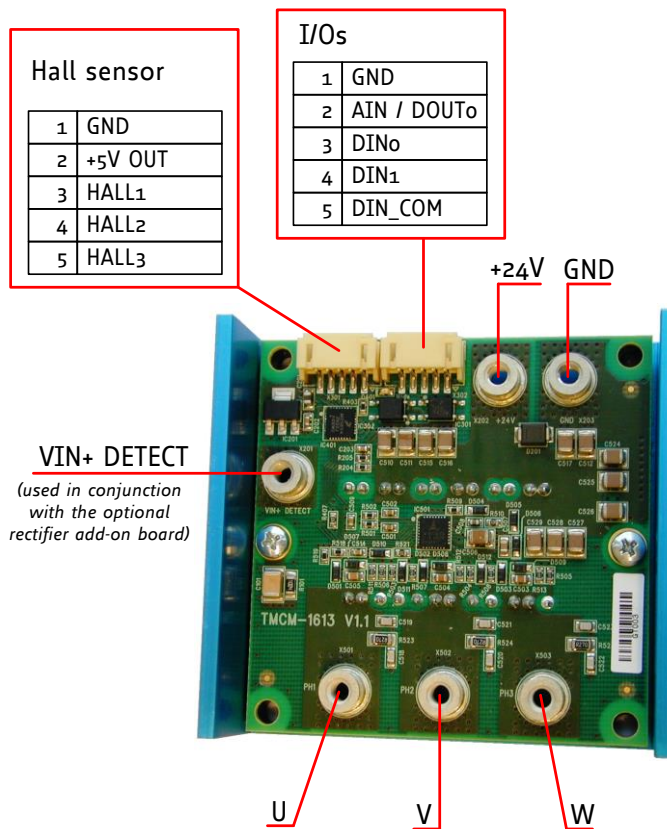

Figure 5.1: TMCM-1613 connectors

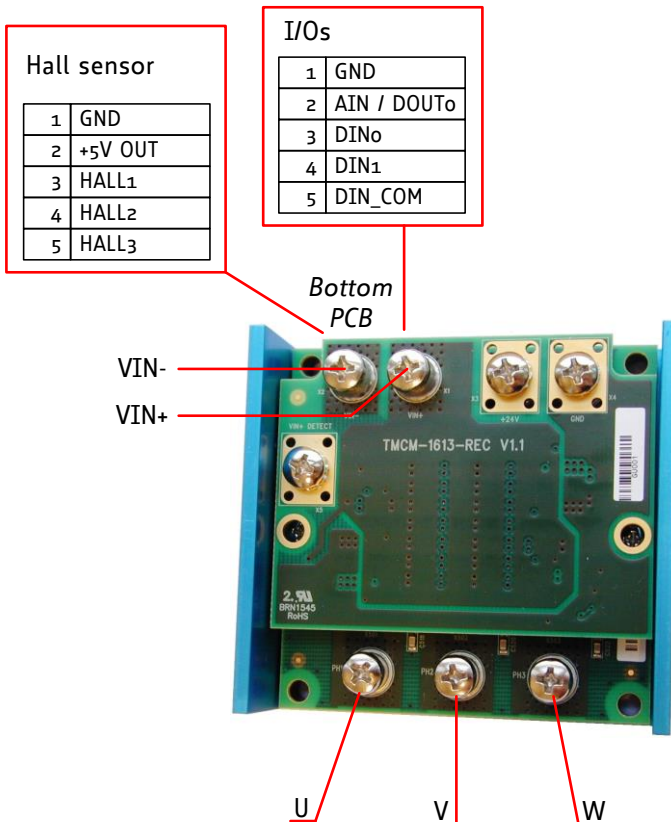

Figure 5.2: TMCM-1613-REC connectors

Label	Description	Connector type	Mating connector type
+24V	Supply input	M4 contact	M4 screw 6mm length recommended
GND	Supply ground	M4 contact	M4 screw 6mm length recommended
VIN+	Supply input (Rectifier input)	M4 contact	M4 screw 6mm length recommended
VIN-	Supply input (Rectifier input)	M4 contact	M4 screw 6mm length recommended
VIN+ DETECT	Supply voltage polarity detection (required for optional rectifier add-on board)	M4 contact	M4 screw
U	BLDC motor phase / coil connection U	M4 contact	M4 screw
V	BLDC motor phase / coil connection V	M4 contact	M4 screw
W	BLDC motor phase / coil connection W	M4 contact	M4 screw
Hall sensor	Input for digital motor hall sensor signals	JST S5B-PH-SM4-TB (JST PH series, 5pins, 2mm pitch)	Connector housing: JST PHR-5 Contacts: JST SPH-002T-P0.5S Wire: 0.22mm ² , AWG 24
I/Os	1x analog input and 2x digital inputs (optically isolated)	JST S5B-PH-SM4-TB (JST PH series, 5pins, 2mm pitch)	Connector housing: JST PHR-5 Contacts: JST SPH-002T-P0.5S Wire: 0.22mm ² , AWG 24

Table 5.1 Connectors and mating connectors

5.1 TMC-1613 Power supply connection

The TMC-1613 module offers two M4 contacts for power supply input connection.

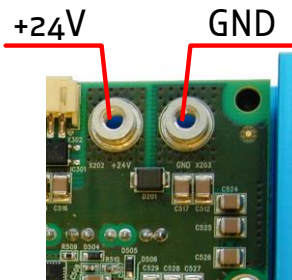

Figure 5.3: TMC-1613 Power supply input

CAUTION
<p>Always keep the power supply voltage (+24V) below the upper limit of 30V! Otherwise the driver electronics will be seriously damaged. Especially, when the selected operating voltage is near the upper limit a regulated power supply is highly recommended.</p>
<p>Prevent power supply rising above upper supply voltage limit of 30V! The motor might generate power e.g. during fast deceleration or while being rotated by an external source. The generated energy will be supplied back into the module supply rail (+24V). Please make sure the supply voltage does not exceed 30V!</p>
<p>There is no reverse polarity protection! The module will short any reversed supply voltage due to internal diodes of the driver transistors.</p>

Add external power supply capacitors!

It is recommended to connect electrolytic capacitors of significant size to the power supply lines next to the TMCM-1613!

Rule of thumb for size of electrolytic capacitor: $c = 1000 \frac{\mu\text{F}}{\text{A}} \times I_{\text{SUPPLY}}$

The capacitors should be selected with regard to high ripple current rating. In addition to power stabilization (buffer) and filtering this added capacitor will also reduce any voltage spikes which might otherwise occur from a combination of high inductance power supply wires and the ceramic capacitors. In addition it will limit slew-rate of power supply voltage at the module. The low ESR of ceramic-only filter capacitors may cause stability problems with some switching power supplies.

5.2 TMCM-1613-REC Power supply connection

The TMCM-1613-REC module offers two M4 contacts for power supply connection.

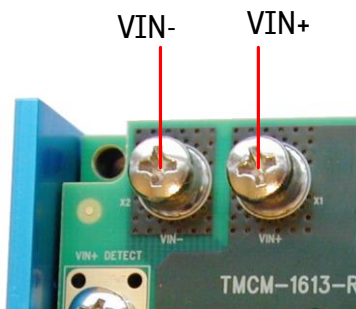

Figure 5.4: TMCM-1613-REC Power supply input

VIN+ is the nominal positive supply input – VIN- the nominal negative supply input. Nevertheless, any reverse polarity will be detected by the unit and internally corrected (reversed). Please note: the integrated active rectifier has been designed in order to support motor control based on supply voltage level (motor speed) and supply voltage polarity (motor direction) as commonly known from DC-motor control. It is not suitable for rectifying AC supply (e.g. 50/60Hz).

CAUTION

Always keep the power supply voltage (+24V) below the upper limit of 30V!

Otherwise the driver electronics will be seriously damaged. Especially, when the selected operating voltage is near the upper limit a regulated power supply is highly recommended.

Prevent power supply rising above upper supply voltage limit of 30V!

The motor might generate power e.g. during fast deceleration or while being rotated by an external source. The generated energy will be supplied back into the module supply rail (+24V). Please make sure the supply voltage does not exceed 30V!

Add external power supply capacitors!

It is recommended to connect electrolytic capacitors of significant size to the power supply lines next to the TMCM-1613!

Rule of thumb for size of electrolytic capacitor: $c = 1000 \frac{\mu\text{F}}{\text{A}} \times I_{\text{SUPPLY}}$

The capacitors should be selected with regard to high ripple current rating. In addition to power stabilization (buffer) and filtering this added capacitor will also reduce any voltage spikes which might otherwise occur from a combination of high inductance power supply wires and the ceramic capacitors. In addition it will limit slew-rate of power supply voltage at the module. The low ESR of ceramic-only filter capacitors may cause stability problems with some switching power supplies.

5.3 BLDC motor connection

The module offers three M4 screw contacts for BLDC motor connection.

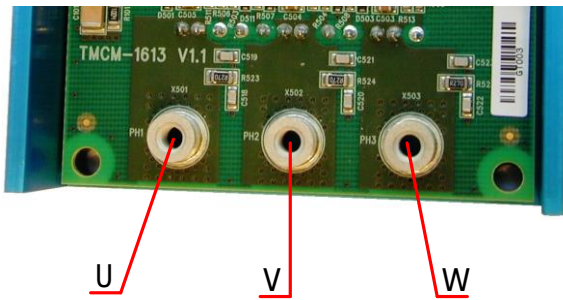

Figure 5.5: BLDC motor coil connection

In addition to the motor coils please make sure to connect motor hall sensor signals, also (see hall sensor connector).

CAUTION
<i>Please do not connect or disconnect motor coils during operation (while power supply switched on)!</i>

5.4 VIN+ DETECT (TMCM-1613 only)

This M4 screw contact is used by the optional rectifier add-on board (part of the TMCM-1613-REC) in order to detect the supply voltage polarity of the TMCM-1613-REC supply voltage input.

5.5 Hall sensor connector (TMCM-1613 and TMCM-1613-REC)

The module offers a 5pin JST PH series connector for motor hall sensor signal connection.

	Pin	Label	Direction	Description
	1	GND		Hall sensor signal ground. Connected to supply ground
	2	+5V_OUT	Output	+5V output for supply of the motor hall sensors (max. 10mA)
	3	HALL1	Input	Hall sensor input 1 (phase U)
	4	HALL2	Input	Hall sensor input 2 (phase V)
	5	HALL3	Input	Hall sensor input 3 (phase W)

Table 5.1: Hall sensor connector

5.6 I/O connector (TMCM-1613 and TMCM-1613-REC)

The module offers a 5pin JST PH series connector for one analog input (0..10V), one digital output (open-drain, max. 100mA, 30V) and two digital inputs (for +24V signals). The two digital inputs are optically isolated. This way they can be used with the DC motor emulation mode with the optional rectifier add-on board without additional external protection circuit.

	Pin	Label	Direction	Description
	1	GND		Analog input and digital output signal ground. Connected to supply ground
	2	AIN / DOUTo	Input / Output	Can be used either as analog input (0..10V) or as digital output (open-collector, max. 100mA, 30V)
	3	DINo	Input	Digital input 0 (optically isolated)
	4	DIN1	Input	Digital input 1 (optically isolated)
	5	DIN_COM	Input	Hall sensor input 3 (common supply input for both digital inputs)

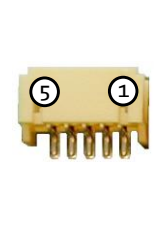
Table 5.2: Hall sensor connector

5.6.1 Digital inputs

The digital inputs support the connection of high-side (typically referred to as pnp) and low-side (typically referred to as npn) switches. The common supply input for the digital inputs has to be connected either to GND or to supply voltage of the input signals.

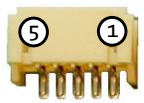
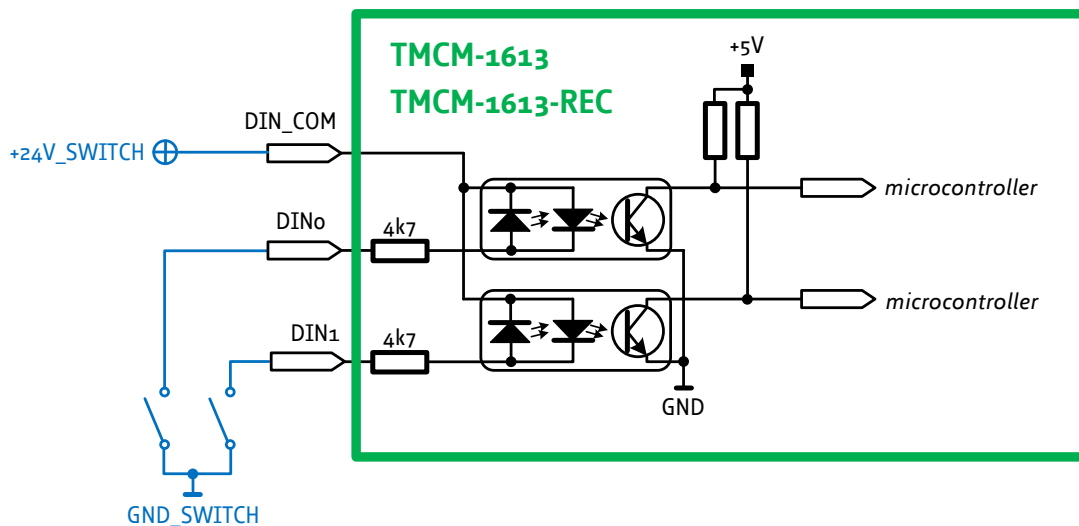

Figure 5.6 Using NPN switches (connection to GND) for the digital inputs

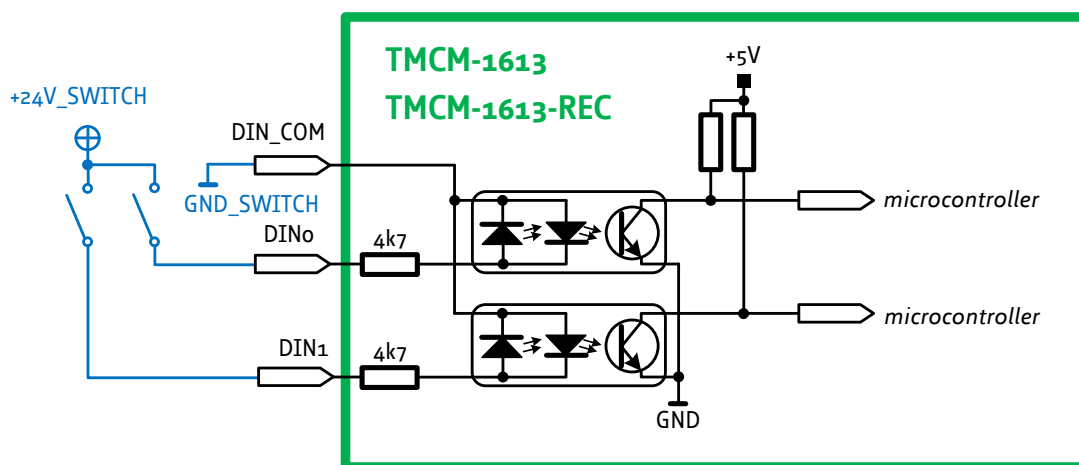

Figure 5.7 Using PNP switches (connection to input signal supply / +24V) for the digital inputs

5.6.2 Analog input

There is one analog input available (nominal 0..10V input range). Input voltages up-to 20V can be measured by the integrated ADC (12bit resolution).

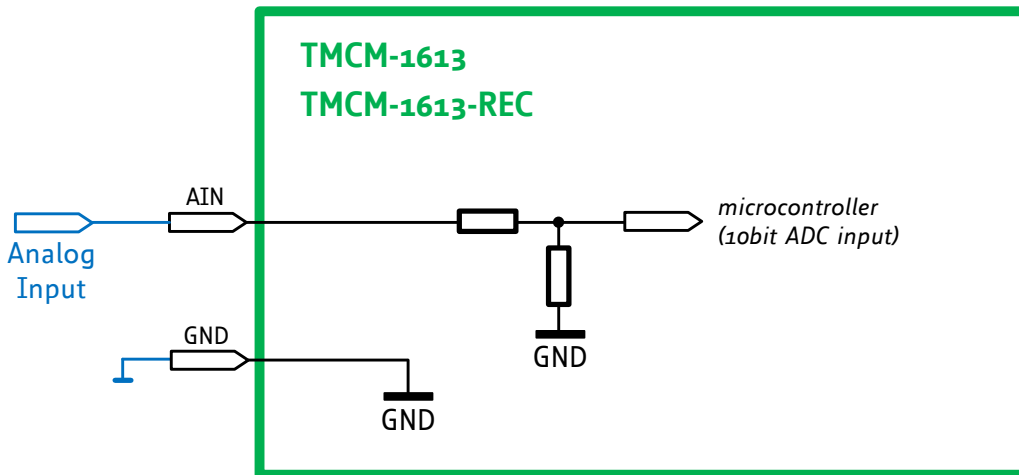

Figure 5.8 Using the analog input

Please note: in contrast to the two digital inputs the analog input is not optically isolated. The ground reference for the analog input is internally connected to the ground connection of the supply input.

5.6.3 Digital Output

There is one digital output available (open-drain output). This digital output and the analog input share the same pin on the I/O connector. When activated this output can sink up-to 100mA through an external load connected to the output.

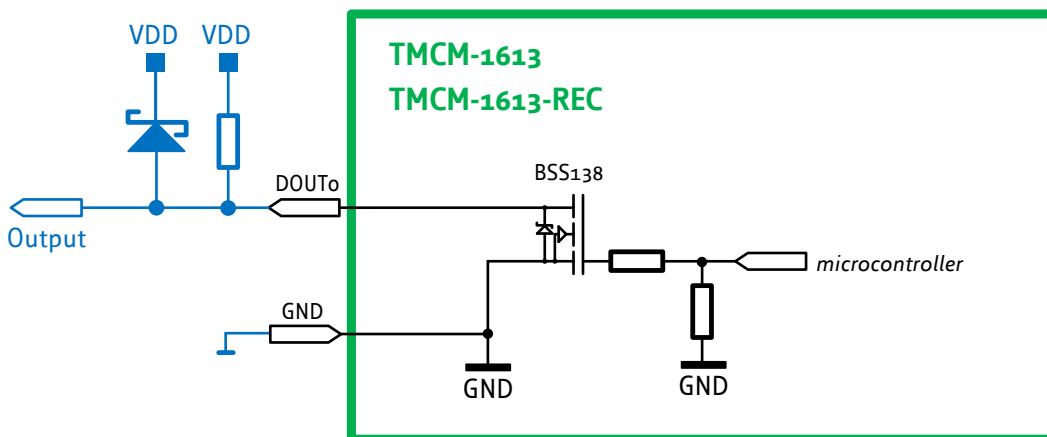

Figure 5.8 Using the output (open-drain)

The external resistor in figure 5.8 (printed in blue) may be replaced with the actual load.

Please note: the external diode shown in figure 5.8 is optional for resistive loads. For any inductive load (e.g. relais coil etc.) please add the external diode (as indicated above).

Please note: in contrast to the digital inputs the digital output is not optically isolated. The ground reference for the digital output is internally connected to the ground connection of the supply input.

5.6.4 Serial communication

For serial communication with the TMCM-1613 a dedicated adapter dongle TMCM-1613-USB is available which offers USB connection and integrated galvanic isolation for communication between PC (e.g. using the TMCL-IDE) and the TMCM-1613 or TMCM-1613-REC. Especially with the TMCM-1613-REC and support for reverse polarity supply an isolated communication is mandatory / highly recommended.

For more simple setups or integration of the TMCM-1613 into embedded control systems a simple RS232 or even TTL UART interface might be preferred.

The TMCM-1613 will accept serial data via DINo (optically isolated) and will send reply data via DOUTo. Communication speed is limited to max. 9600Baud (which is also default with standard TMCL firmware). In order to activate the serial communication on the TMCM-1613 a voltage above around 15V has to be applied to the analog input AIN at power-up (see also firmware manual for more details). Please note that this voltage should be applied current limited (e.g. via resistor) as the same pin is used as output for sending reply datagram afterwards.

Please find below an example schematic for UART TTL (+5V) connection:

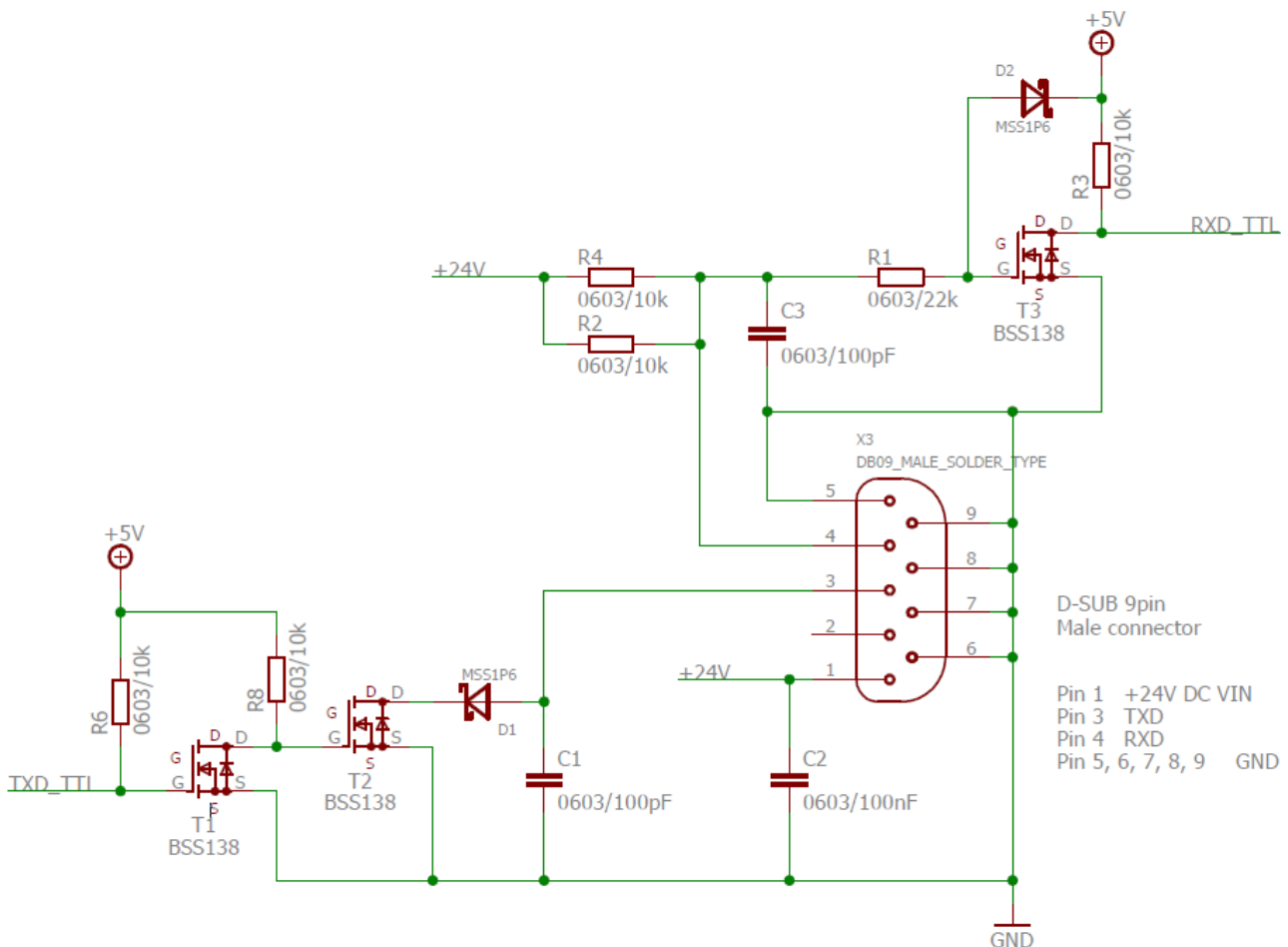

Figure 5.9: Example circuit for UART TTL (+5V) connection to TMCM-1613 / TMCM-1613-REC (connection via X3)

In schematic above TXD (Pin 3 of X3) has to be connected to DINo (Pin 3 of I/O connector) of the TMCM-1613 / TMCM-1613-REC and RXD (Pin 4 of X3) has to be connected to DOUTo (Pin 2 of I/O connector) of the TMCM-1613 / TMCM-1613-REC. Please make sure to connect +24V to DIN_COM (Pin 5 of I/O connector) of the TMCM-1613 / TMCM-1613-REC and Pin 1 of X3 in schematic above and connect GND between the circuit above and the TMCM-1613 / TMCM-1613-REC (e.g. using Pin 1 of the I/O connector and one of the GND pins on X3).

The circuit above maybe extended for full RS232 signal levels using the following schematic:

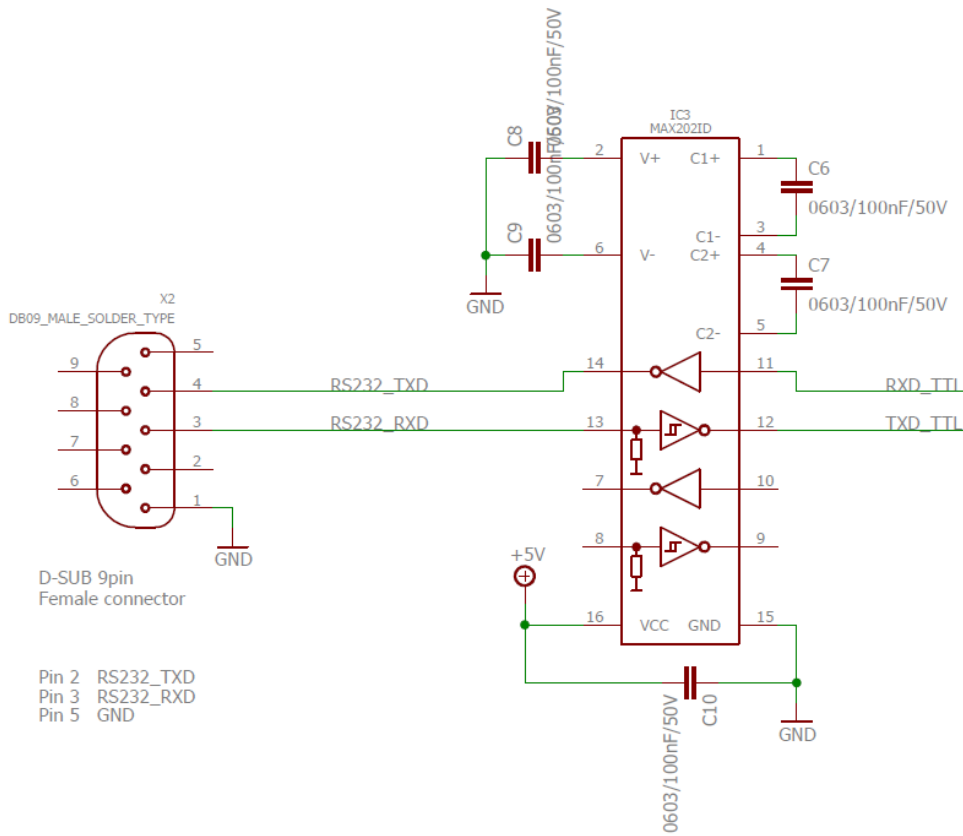

Figure 5.10: RS232 interface extension

Design files for an adapter dongle using the circuit above may be downloaded from our website.

6 On-board LEDs

The TMC-1613 board offers one green LEDs. This is located close to the two 5pin JST PH series connectors. The function of the LED is firmware dependent. With current firmware version the LED will be flashing slowly during standard firmware execution.

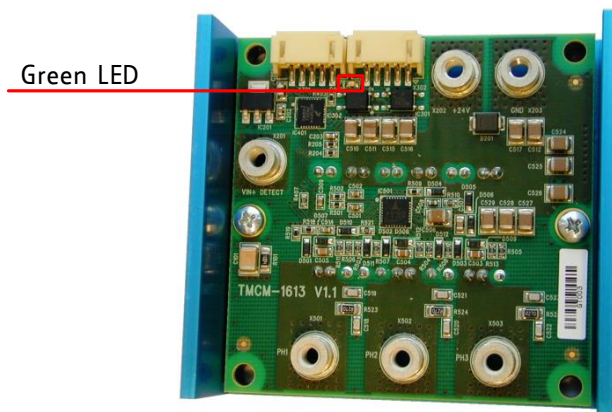

Figure 6.1: On-board green LED

7 Operational ratings

The operational ratings show the intended or the characteristic ranges and should be used as design values. ***In no case shall the maximum values be exceeded.***

Symbol	Parameter	Min	Typ	Max	Unit
+24V	Power supply voltage for driver	7	24	30*)	V
I _{SUPPLY_MAX}	Maximum power supply input current		22		A
I _{MOTOR_MAX}	Max motor current (peak for one phase)		35		A
T _{ENV_MAX}	Maximum environmental temperature (with maximum rated power)	-30		+50	°C

Table 7.1: General operational ratings of the module

*) absolute max. (even for short time). Supply voltage spikes especially with higher load should be taken into account here. At higher supply voltages it is strongly recommended to add external buffer / filter capacitors to the supply input.

OPERATIONAL RATINGS OF HALL SIGNAL INPUTS

Symbol	Parameter	Min	Typ	Max	Unit
I _{+5V_MAX}	Maximum current available for supply of external hall sensors		10		mA
V _{HALL}	Hall sensor signal voltage range (push-pull and open-collector digital signals are supported)	0		5.5	V

Table 7.2 Operational ratings of hall sensor signal inputs

OPERATIONAL RATINGS OF INPUTS AND OUTPUT

Symbol	Parameter	Min	Typ	Max	Unit
V _{DIN}	Voltage range for digital inputs DIN ₀ and DIN ₁	0		+24	V
I _{DIN_H}	Current for activating digital inputs DIN ₀ and DIN ₁ (through LED of photocoupler and 4k7 resistor)	0.6 (-4V)		5 (-24V)	mA
V _{AINO}	Voltage range for the analog input AINO (nominal)	0		10	V
V _{AINO_MAX}	Voltage range for the analog input AINO (max analog input range)	0		20	V
V _{OUT0}	Voltage range for the digital output (open-drain)	0		30	V
I _{OUT0_MAX}	Max. current the digital open-drain output is able to pull-down without damage			100	mA

Table 7.3 Operational ratings of inputs and outputs

8 Functional Description

The TCM-1613 / TCM-1613-REC modules are highly integrated powerful (up-to 500W) BLDC controller / driver units for typical supply voltages of +12V and +24V. The units offer easy setup of BLDC motor control applications supporting hall sensor based block-commutation of the attached BLDC motor. Two digital inputs and one analog input are available together with a number of pre-defined stand-alone operating modes (please see separate firmware manual for more details). An optional USB converter dongle supports full remote control of all main parameters with the option to store settings permanently on the units. An optional active input supply rectifier (part of the TCM-1613-REC) allows DC-motor like control of a BLDC motor (supply voltage level defined velocity and supply voltage polarity defined direction of rotation)

In Figure 8.1 / 8.2 the main parts of the TCM-1613 / TCM-1613-REC are shown:

- Microcontroller, responsible for overall control and 3-phase pwm generation
- Pre-driver with integrated analog amplifier for the single-shunt motor current measurement (based on TMC6130)
- MOSFET driver bridge
- *Part of the TCM-1613-REC, only: active rectifier at supply input*

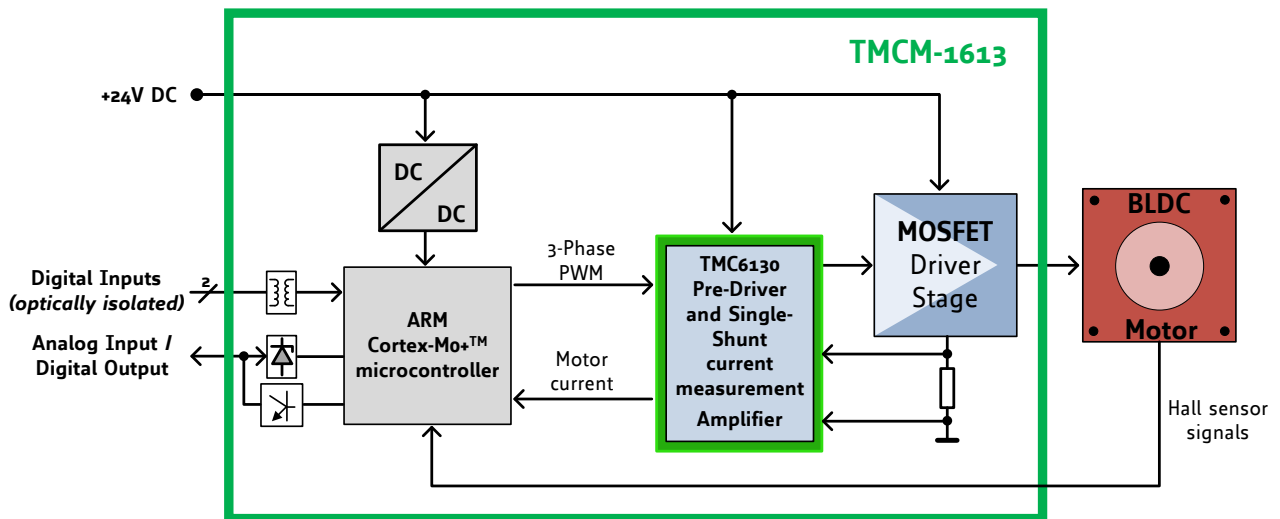

Figure 8.1: Main parts of the TCM-1613

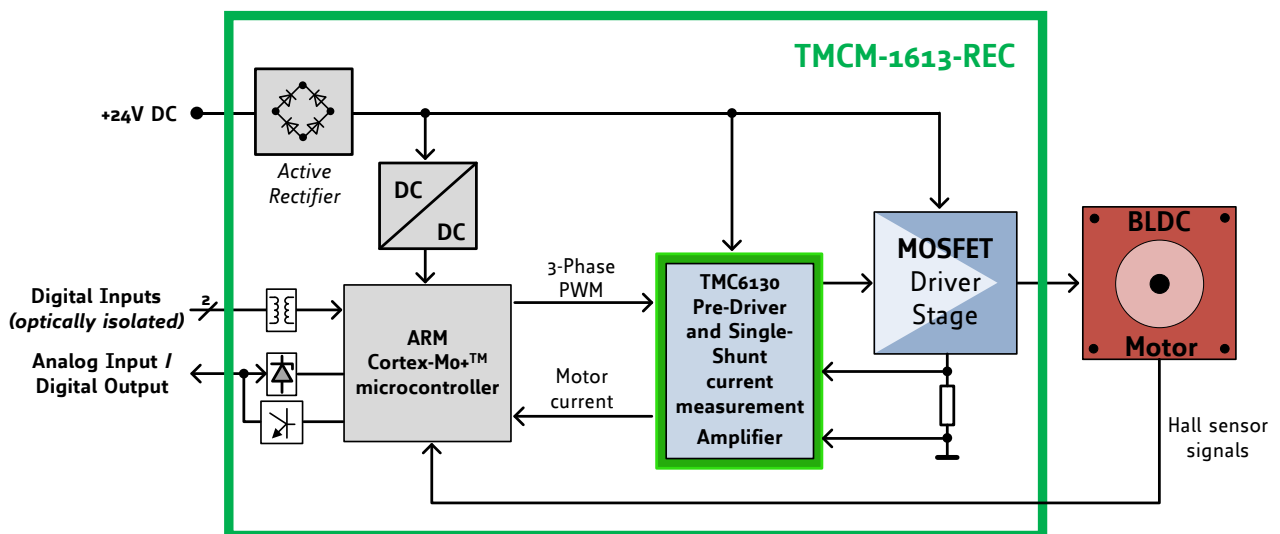

Figure 8.2: Main parts of the TCM-1613-REC

9 Revision History

9.1 Document revision

Version	Date	Author	Description
0.90	2015-DEC-14	GE	Initial version
0.91	2016-MAR-29	GE	<ul style="list-style-type: none"> Several corrections Block diagrams added Connection for TMC-1613-REC added
0.92	2017-OCT-06	GE	TMC-1613-CABLE contents corrected: Screws removed as they are already delivered with the modules.
1.00	2017-OCT-27	GE	<ul style="list-style-type: none"> Minor corrections Analog input and digital output more detailed description added (chapter 5.6.2 and 5.6.3) Serial interface detailed description and example circuit added (chapter 5.6.4)

Table 9.1: Document revision

9.2 Hardware revision

Version	Date	Description
TMC-1613_V10	2015-JUL-30	Initial version
TMC-1613_V11	2015-OCT-27	Redesign with the following main modifications: <ul style="list-style-type: none"> Protection diodes for the pre-driver low-side outputs SMT M4 power contacts instead of THT versions Separate receive and transmit lines for the optional communication interface

Table 9.2: Hardware revision TMC-1613

Version	Date	Description
TMC-1613-REC_V10	2015-JUL-31	Initial version
TMC-1613-REC_V11	2015-OCT-27	Redesign with the following main modifications: <ul style="list-style-type: none"> SMT M4 power contacts instead of THT versions

Table 9.3: Hardware revision TMC-1613-REC rectifier add-on board

Version	Date	Description
TMC-1613-USB_V10	2015-AUG-27	Initial version
TMC-1613-USB_V11	2015-OCT-22	Redesign with the following main modifications: <ul style="list-style-type: none"> Separate transmit and receive data lines for communication with the TMC-1613

Table 9.4: Hardware revision of TMC-1613-USB communication dongle

10 References

- [JST] JST connector
<http://www.jst.com/>
- [TMC6130] TMC6130 datasheet
Manual available on <http://www.trinamic.com>.
- [TMCL-IDE] TMCL-IDE User Manual
Manual available on <http://www.trinamic.com>.