



Chipsmall Limited consists of a professional team with an average of over 10 year of expertise in the distribution of electronic components. Based in Hongkong, we have already established firm and mutual-benefit business relationships with customers from,Europe,America and south Asia,supplying obsolete and hard-to-find components to meet their specific needs.

With the principle of “Quality Parts,Customers Priority,Honest Operation,and Considerate Service”,our business mainly focus on the distribution of electronic components. Line cards we deal with include Microchip,ALPS,ROHM,Xilinx,Pulse,ON,Everlight and Freescale. Main products comprise IC,Modules,Potentiometer,IC Socket,Relay,Connector.Our parts cover such applications as commercial,industrial, and automotives areas.

We are looking forward to setting up business relationship with you and hope to provide you with the best service and solution. Let us make a better world for our industry!



## Contact us

Tel: +86-755-8981 8866 Fax: +86-755-8427 6832

Email & Skype: info@chipsmall.com Web: www.chipsmall.com

Address: A1208, Overseas Decoration Building, #122 Zhenhua RD., Futian, Shenzhen, China



# TMD4903

## Color and Proximity Sensor Module with mobeam™ Barcode Emulation and IR Remote Control

### General Description

The TMD4903 features ambient light and color (RGB) sensing, proximity detection and IRBeam optical pattern generator capable of mobeam™ barcode emulation and IR remote control. In addition, the device integrates an IR LED and advanced LED driver, all within a low-profile and small footprint, 2.0mm x 5.0mm x 1.0mm package.

The Proximity sensing function synchronizes IR emission and detection to sense proximity events. The architecture of the engine features self-maximizing dynamic range, ambient light subtraction, advanced crosstalk cancelation, 14-bit data output, 32-dataset FIFO, and interrupt-driven I<sup>2</sup>C communication. Sensitivity, power consumption, and noise can be optimized with adjustable IR LED timing and power. The proximity engine recognizes detect/release events and produces a configurable interrupt whenever proximity result crosses upper or lower threshold settings.

The Ambient Light and Color Sensing function provides Red, Green, and Blue (RGB) ambient light sensing with a Clear reference (C). The color diode array has a UV/IR blocking filter and parallel ADCs to produce simultaneous 16-bit results. This architecture accurately measures ambient light and enables the calculation of illuminance, chromaticity, and color temperature to manage display appearance.

The IRBeam pattern generator supports mobeam™ barcode emulation and IR remote control. The engine features RAM for pattern storage and specialized control logic that is tailored to repetitively broadcast a barcode pattern using the integrated LED or an external LED with a low side driver. The IRBeam engine features adjustable timing, looping, and IR intensity to maximize successful transmission. IRBeam is designed to support all requirements for 1-D barcode transmission over IR to point-of-sale (POS) terminals as well as IR remote control.

*[Ordering Information](#) and [Content Guide](#) appear at end of datasheet.*

## Key Benefits & Features

The benefits and features of TMD4903, Color and Proximity Sensor Module with mobeam™ Barcode Emulation and IR Remote Control are listed below:

**Figure 1:**  
Added Value of Using TMD4903

Benefit	Feature
<ul style="list-style-type: none"> <li>Proximity detection</li> </ul>	<ul style="list-style-type: none"> <li>Selectable direction sensitivity</li> <li>Ambient light rejection</li> <li>Advanced crosstalk compensation</li> <li>AFE saturation flag</li> <li>Programmable LED driver</li> <li>Interrupt-Driven I<sup>2</sup>C communication</li> </ul>
<ul style="list-style-type: none"> <li>Ambient light and color sensing</li> </ul>	<ul style="list-style-type: none"> <li>Variable sensitivity</li> <li>Designed to operate behind inked glass</li> <li>UV/IR blocking filter</li> <li>Programmable gain and integration time</li> <li>6.7M:1 dynamic range by gain adjustment only</li> <li>Interrupt-driven I<sup>2</sup>C communication</li> </ul>
<ul style="list-style-type: none"> <li>IRBeam pattern generator</li> </ul>	<ul style="list-style-type: none"> <li>mobeam™ support</li> <li>Universal remote control support</li> <li>Interrupt-driven I<sup>2</sup>C communication</li> </ul>
<ul style="list-style-type: none"> <li>Integrated LED and driver</li> </ul>	<ul style="list-style-type: none"> <li>Calibrated emission and response</li> <li>Invisible 950nm emission</li> </ul>
<ul style="list-style-type: none"> <li>Low supply voltage</li> </ul>	<ul style="list-style-type: none"> <li>1.8V operation</li> </ul>

## Applications

The TMD4903 applications include:

- Color sensing
- Ambient light sensing
- Cell phone touch screen disable
- Mechanical switch replacement
- 1D barcode emulation
- Universal remote control

### Block Diagram

The functional blocks of this device are shown below:

**Figure 2:**  
TMD4903 Block Diagram

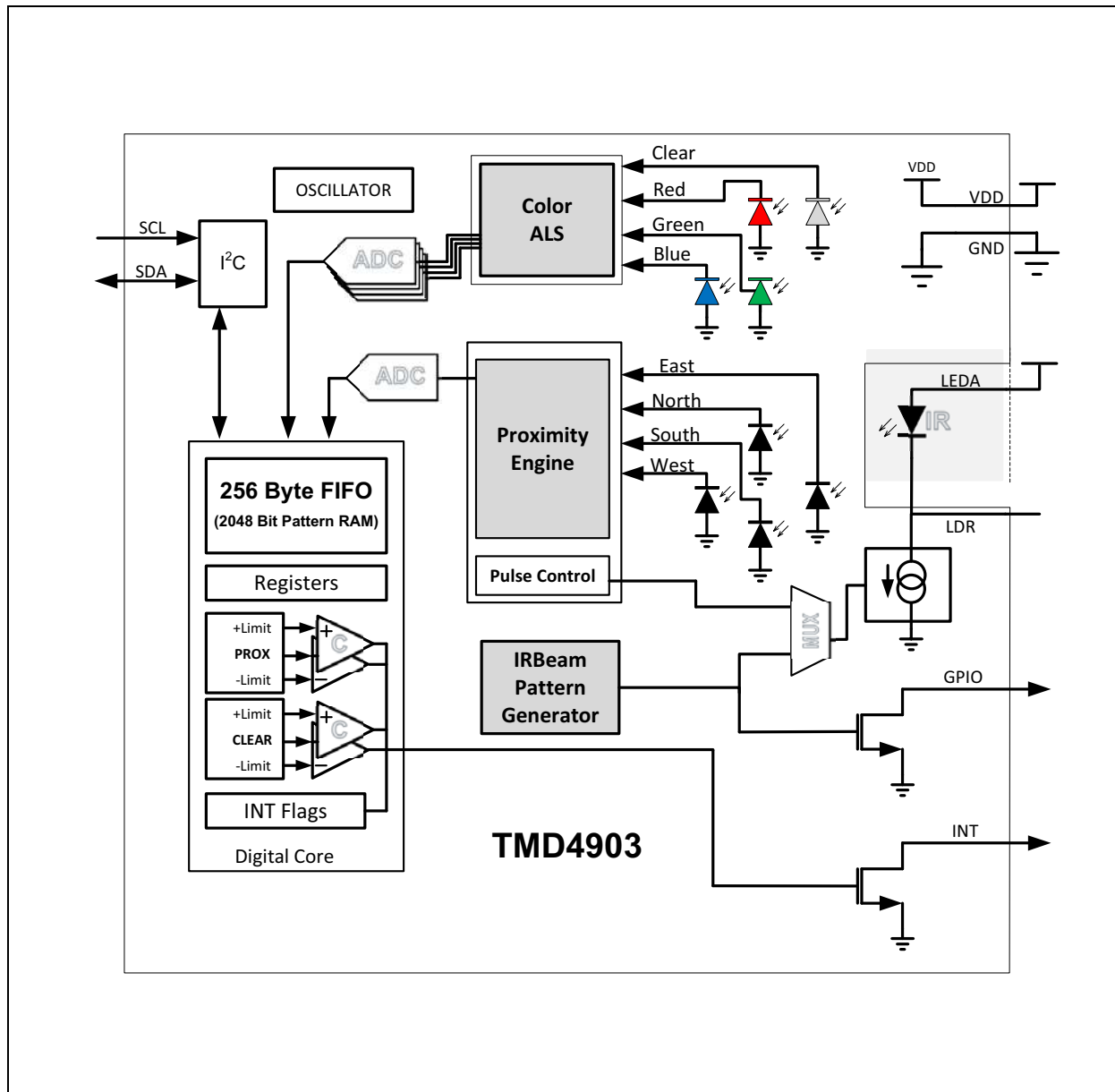

## Pin Assignment

The device pin assignments are described below.

**Figure 3:**  
Pin Diagram

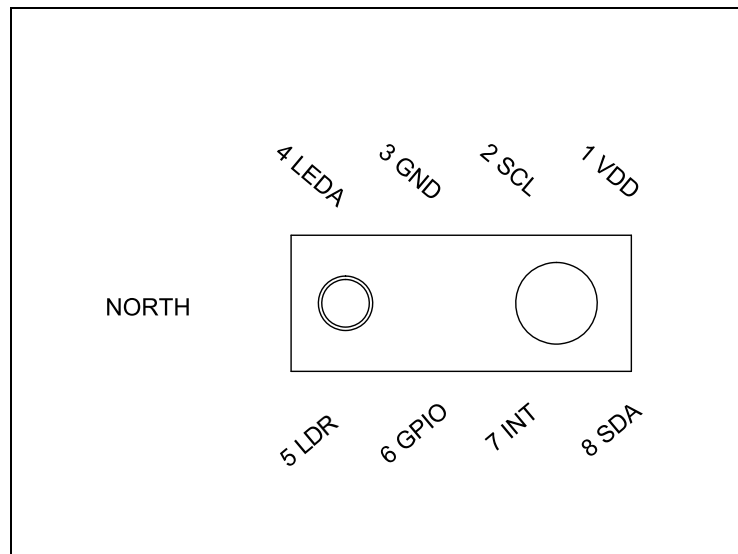

## Pin Description

**Figure 4:**  
Pin Description

Pin Number	Pin Name	Description
1	V <sub>DD</sub>	Supply voltage (1.8V)
2	SCL	I <sup>2</sup> C serial clock terminal
3	GND	Ground. All voltages are referenced to GND
4	LEDA	LED anode
5	LDR	LED driver (sinks current) and LED cathode (for direct access to LED)
6	GPIO	Open drain IRBeam output or alternate interrupt
7	INT	Interrupt. Open drain output and logic level output for external IR LED circuit
8	SDA	I <sup>2</sup> C serial data I/O terminal

## Absolute Maximum Ratings

Stresses beyond those listed under Absolute Maximum Ratings may cause permanent damage to the device. These are stress ratings only. Functional operation of the device at these or any other conditions beyond those indicated under [Recommended Operating Conditions](#) is not implied. Exposure to absolute maximum rating conditions for extended periods may affect device reliability.

**Figure 5:**  
Absolute Maximum Ratings

Symbol	Parameter	Min	Max	Units	Comments
$V_{DD}$	Supply voltage	-0.3	2.2	V	
$V_{LEDA}$	LED anode supply	-0.3	3.6	V	
$V_{IO}$	Digital I/O terminal voltage	-0.3	3.6	V	
$V_{LDR}$	Terminal voltage	-0.3	3.6	V	See note (2)
$I_{IO}$	Output terminal current	-1	20	mA	
$T_{strg}$	Storage temperature range	-40	85	°C	
$ESD_{HBM}$	ESD tolerance, human body model	±2000		V	

**Note(s):**

1. All voltages with respect to GND.
2. Measured with LDR = OFF or LDR = ON and LDRIVE = 310mA.

## Electrical Characteristics

The parameters with min and max values are guaranteed with production tests or SQC (Statistical Quality Control) methods.

**Figure 6:**  
Recommended Operating Conditions

Symbol	Parameter	Min	Typ	Max	Units
$V_{DD}$	Supply voltage	1.7	1.8	2.0	V
$T_A$	Operating free-air temperature <sup>(1)</sup>	-30		85	°C

**Note(s):**

1. While the device is operational across the temperature range, functionality will vary with temperature. Specifications are stated at 25°C, unless otherwise noted.

**Figure 7:**  
Operating Characteristics,  $V_{DD} = 1.8\text{ V}$ ,  $T_A = 25^\circ\text{C}$  (unless otherwise noted)

Symbol	Parameter	Conditions	Min	Typ	Max	Units
$f_{OSC}$	Oscillator Frequency			8.1		MHz
$I_{DD}$	Supply current <sup>(1)</sup>	Active ALS state (PON=AEN=1, PEN=IBEN=0) <sup>(2)</sup>	90	150	200	$\mu\text{A}$
		Idle state (PON=1, AEN=PEN=IBEN=0) <sup>(3)</sup>		30	60	
		Sleep State <sup>(4)</sup>		0.4	5	
$V_{OL}$	INT, SDA, GPIO output low voltage	6 mA sink current			0.6	V
$I_{LEAK}$	Leakage current, SDA, SCL, INT, GPIO, LDR pins		-5		5	$\mu\text{A}$
$V_{IH}$	SCL, SDA input high voltage		1.26			V
$V_{IL}$	SCL, SDA input low voltage				0.54	V

**Note(s):**

1. Values are shown at the VDD pin and do not include current through the IR LED.
2. This parameter indicates the supply current during periods of ALS integration. If Wait is enabled (WEN=1), the supply current is lower during the Wait period.
3. Idle state occurs when PON=1 and all functions are not enabled.
4. Sleep state occurs when PON = 0 and I<sup>2</sup>C bus is idle. If Sleep state has been entered as the result of operational flow, SAI = 1, PON will remain high.

**Figure 8:**  
**ALS/Color Operating Characteristics, VDD = 1.8 V, T<sub>A</sub> = 25°C, AGAIN = 16x, ATIME = 0xF6 (unless otherwise noted)**

Parameter	Conditions	Min	Typ	Max	Units
Integration time step size <sup>(1), (2)</sup>		2.68	2.78	2.90	ms
Dark ADC count value <sup>(2)</sup>	E <sub>e</sub> = 0 μW/ cm <sup>2</sup> AGAIN: 64x ATIME: 100ms (0xDC)	0	1	3	counts
Gain scaling, relative to 16x gain setting	AGAIN: 1/4x	0.0135		0.0175	x
	AGAIN: 1x	0.058		0.067	
	AGAIN: 4x	0.237		0.263	
	AGAIN: 64x	3.75		4.37	
Clear channel irradiance responsivity	White LED, 2700K	8.94	10.28	11.62	counts/ (μW/ cm <sup>2</sup> )
Lux accuracy <sup>(3)</sup>	White LED, 2700K	90	100	110	%
ADC Noise <sup>(4)</sup>	AGAIN: 16x		0.005		% Full Scale

**Note(s):**

1. Integration time is configured from 1 step (0xFF) to 256 steps (0x00) for a typical range of 2.78ms to 711.11ms. An ATIME setting of 0xFF results in a full-scale count value of 1024. Each additional integration step adds 1024 counts to full scale. To enable 16-bit ADC range, 64 or more integration steps (177.8ms or more) are required (ATIME ≤ 0xC0).
2. The typical 3-sigma distribution is between 0 and 1 count for an AGAIN setting of 16x.
3. Lux accuracy is function of red, green, blue and clear channels, and not 100% production tested.
4. ADC noise is calculated as the standard deviation of 1000 data samples.



**Figure 9:**  
Color Ratio Characteristics, VDD = 1.8V, T<sub>A</sub> = 25°C

Parameter	Test Conditions	Ratio of Color to Clear Channel					
		Red Channel		Green Channel		Blue Channel	
		Min	Max	Min	Max	Min	Max
Color ADC count value ratio: Color/Clear	White LED, 2700 K	45%	65%	19%	39%	15%	40%
	$\lambda_D = 465 \text{ nm}^{(1)}$	0%	15%	10%	42%	70%	90%
	$\lambda_D = 525 \text{ nm}^{(2)}$	4%	25%	60%	85%	10%	45%
	$\lambda_D = 615 \text{ nm}^{(3)}$	80%	110%	0%	14%	5%	24%

**Note(s):**

1. The 465 nm input irradiance is supplied by an InGaN light-emitting diode with the following characteristics: dominant wavelength  $\lambda_D = 465 \text{ nm}$ , spectral halfwidth  $\Delta\lambda_{1/2} = 22 \text{ nm}$ .
2. The 525 nm input irradiance is supplied by an InGaN light-emitting diode with the following characteristics: dominant wavelength  $\lambda_D = 525 \text{ nm}$ , spectral halfwidth  $\Delta\lambda_{1/2} = 35 \text{ nm}$ .
3. The 615 nm input irradiance is supplied by an AlInGaP light-emitting diode with the following characteristics: dominant wavelength  $\lambda_D = 615 \text{ nm}$ , spectral halfwidth  $\Delta\lambda_{1/2} = 15 \text{ nm}$ .

**Figure 10:**  
**Proximity Operating Characteristics, VDD = 1.8 V, T<sub>A</sub> = 25°C (unless otherwise noted)**

Parameter	Conditions	Min	Typ	Max	Unit
ADC conversion time step size			20		μs
Offset (no target response) <sup>(1)</sup>	PGAIN = 2 (4x) PGLDRIVE = 7 (150mA) PGPULSE_LEN = 1 (8μs) No target present After electrical calibration		16	36	counts
Part to part variation <sup>(2)</sup>	PGAIN = 2 (4x) PGLDRIVE = 1 (30mA) PGPULSE_LEN = 1 (8μs) d=23mm round target 30mm target distance After electrical calibration	75	100	125	%
Response, absolute <sup>(3)</sup>	PGAIN = 2 (4x) PGLDRIVE = 7 (150mA) PGPULSE_LEN = 1 (8μs) 100x100mm, 90% reflective Kodak gray card 100mm target distance After electrical calibration	790	990	1190	counts
Noise/Signal <sup>(4)</sup>	PGAIN = 2 (4x) PGLDRIVE = 2 (50mA) PGPULSE_LEN = 1 (8μs) PGPULSE = 7 (8 pulses)			2	%

**Note(s):**

1. Offset varies with power supply characteristics and system noise.
2. Production tested result is the average of 5 readings expressed relative to a calibrated response.
3. Representative result by characterization. Device settings can vary from 1 to 64 pulse count, 4μs to 32μs pulse width, 10mA to 310mA current setting, and 1x to 8x electrical gain. Refer to [Figure 22](#) for device performance with different settings.
4. Production tested result is the range of 20 readings divided by the average response.

Figure 11:  
Proximity Test Circuit

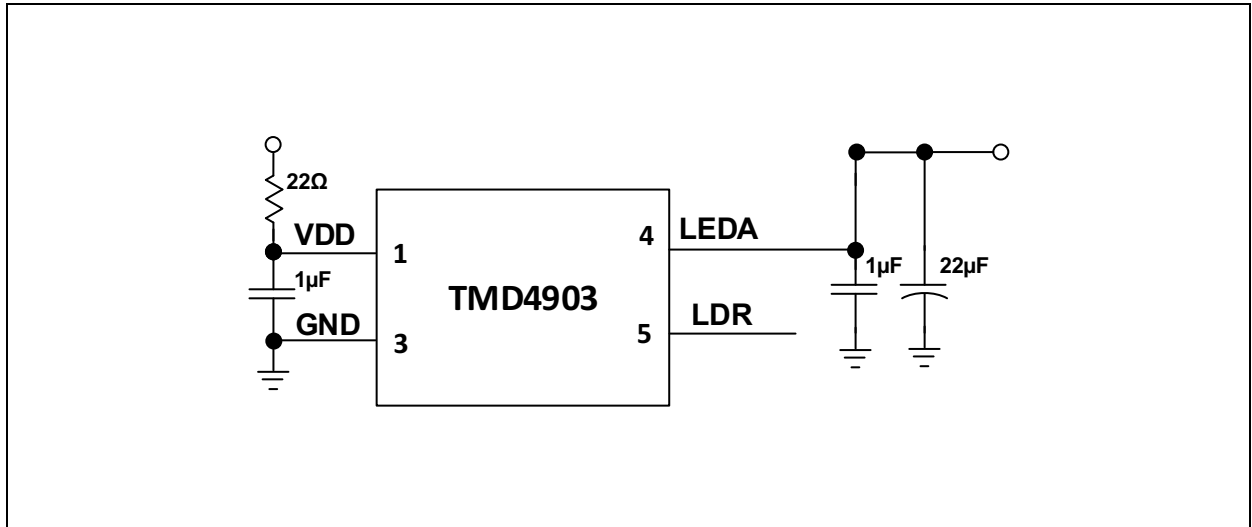

Figure 12:  
Wait Characteristics, VDD = 1.8 V, T<sub>A</sub> = 25°C, WEN = 1 (unless otherwise noted)

Parameter	Conditions	Min	Typ	Max	Units
Wait step size		2.68	2.78	2.90	ms
Long wait step size			33.3		ms

Figure 13:  
IRBeam Operating Characteristics, VDD = 1.8 V, T<sub>A</sub> = 25°C (unless otherwise noted)

Symbol	Parameter	Conditions	Min	Typ	Max	Units
t <sub>(PBT min)</sub>	Minimum bit time	IBEN = 1		0.25		μs

## Timing Characteristics

**Figure 14:**  
AC Electrical Characteristics, VDD = 1.8 V, TA = 25°C (unless otherwise noted)

Parameter	Description	Min	Typ	Max	Unit
f <sub>SCL</sub> <sup>(1)</sup>	Clock frequency (I <sup>2</sup> C only)	0		400	kHz
t <sub>BUF</sub> <sup>(1)</sup>	Bus free time between start and stop condition	1.3			μs
t <sub>HS;STA</sub> <sup>(1)</sup>	Hold time after (repeated) start condition. After this period, the first clock is generated.	0.6			μs
t <sub>SU;STA</sub> <sup>(1)</sup>	Repeated start condition setup time	0.6			μs
t <sub>SU;STO</sub> <sup>(1)</sup>	Stop condition setup time	0.6			μs
t <sub>HD;DAT</sub> <sup>(1)</sup>	Data hold time	0			ns
t <sub>SU;DAT</sub> <sup>(1)</sup>	Data setup time	100			ns
t <sub>LOW</sub> <sup>(1)</sup>	SCL clock low period	1.3			μs
t <sub>HIGH</sub> <sup>(1)</sup>	SCL clock high period	0.6			μs
t <sub>F</sub> <sup>(1)</sup>	Clock/data fall time			300	ns
t <sub>R</sub> <sup>(1)</sup>	Clock/data rise time			300	ns
C <sub>i</sub> <sup>(1)</sup>	Input pin capacitance			10	pF

**Note(s):**

1. Specified by design and characterization; not production tested.

### Timing Diagram

**Figure 15:**  
Timing Parameter Measurement Drawing

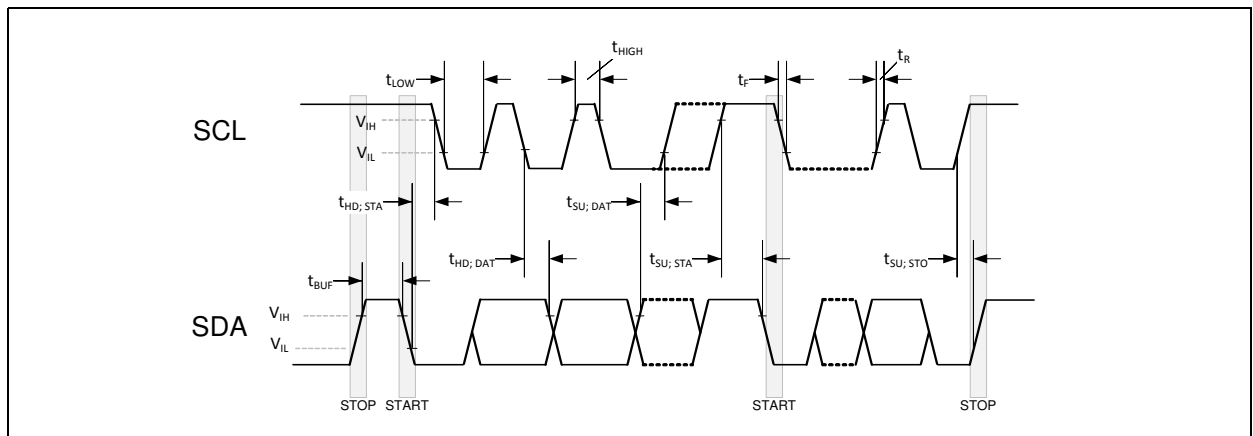

## Typical Operating Characteristics

Figure 16:  
Spectral Responsivity

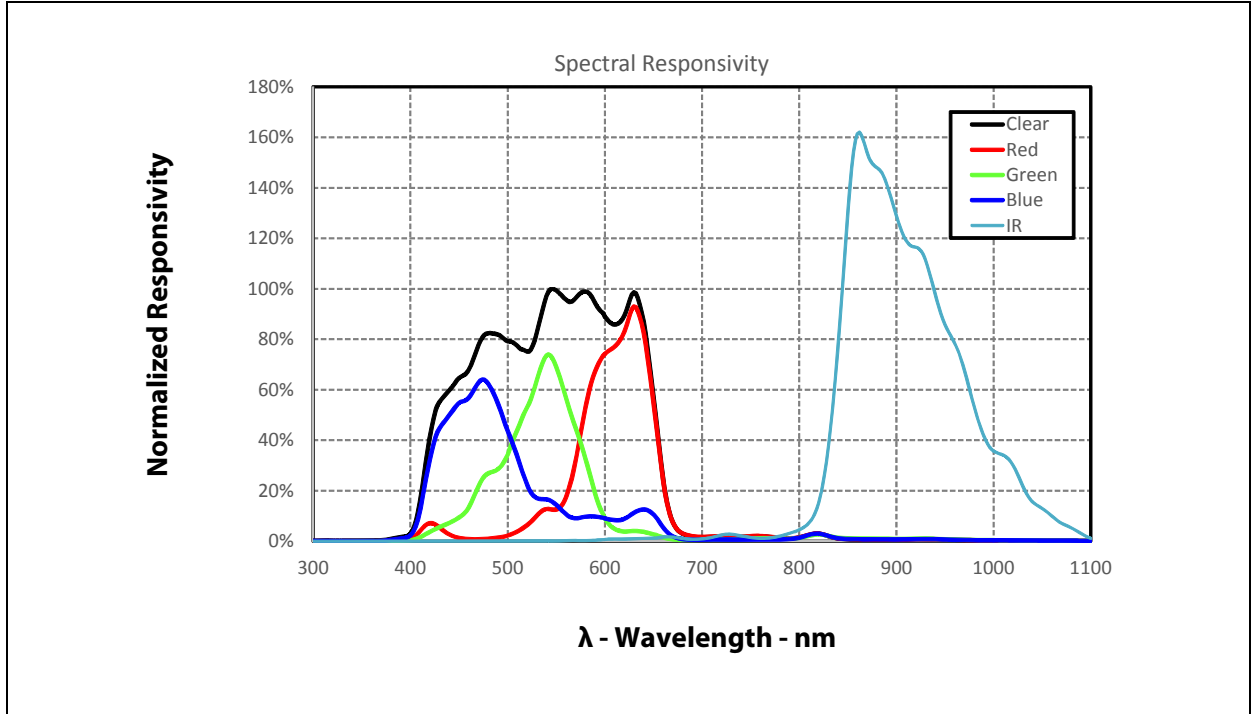
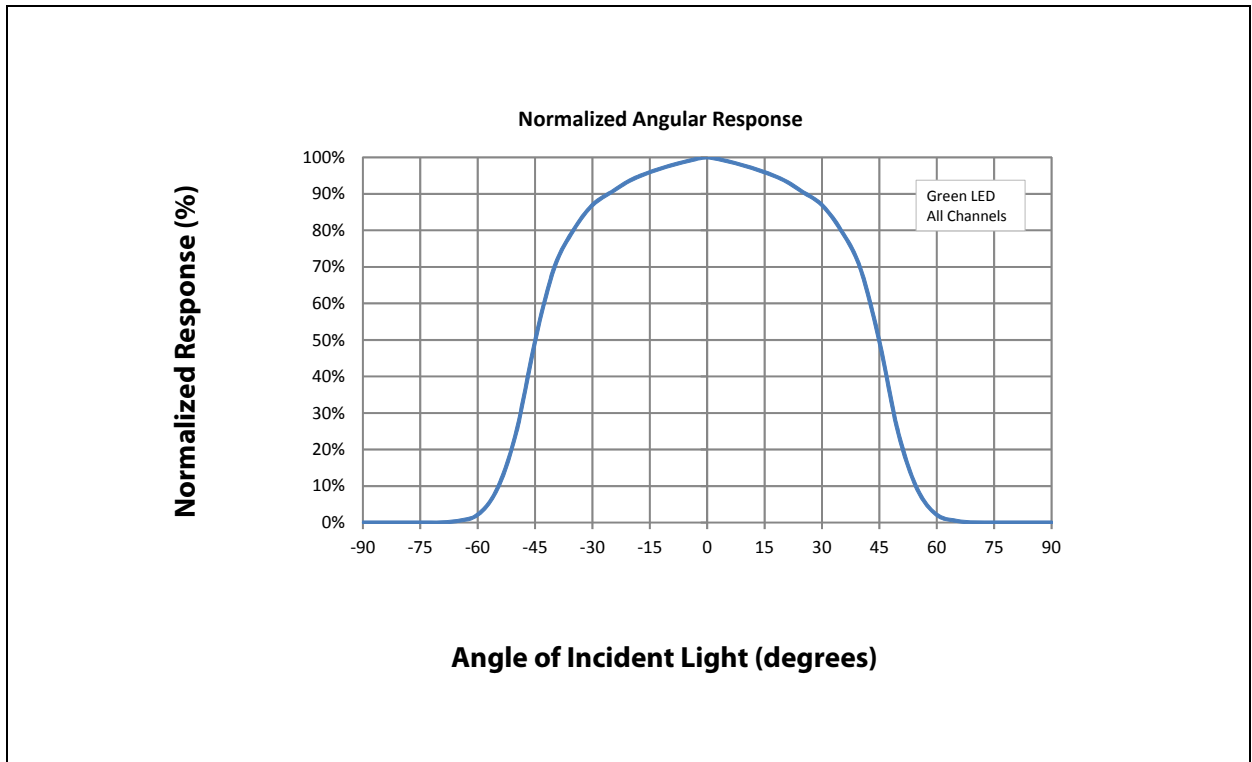
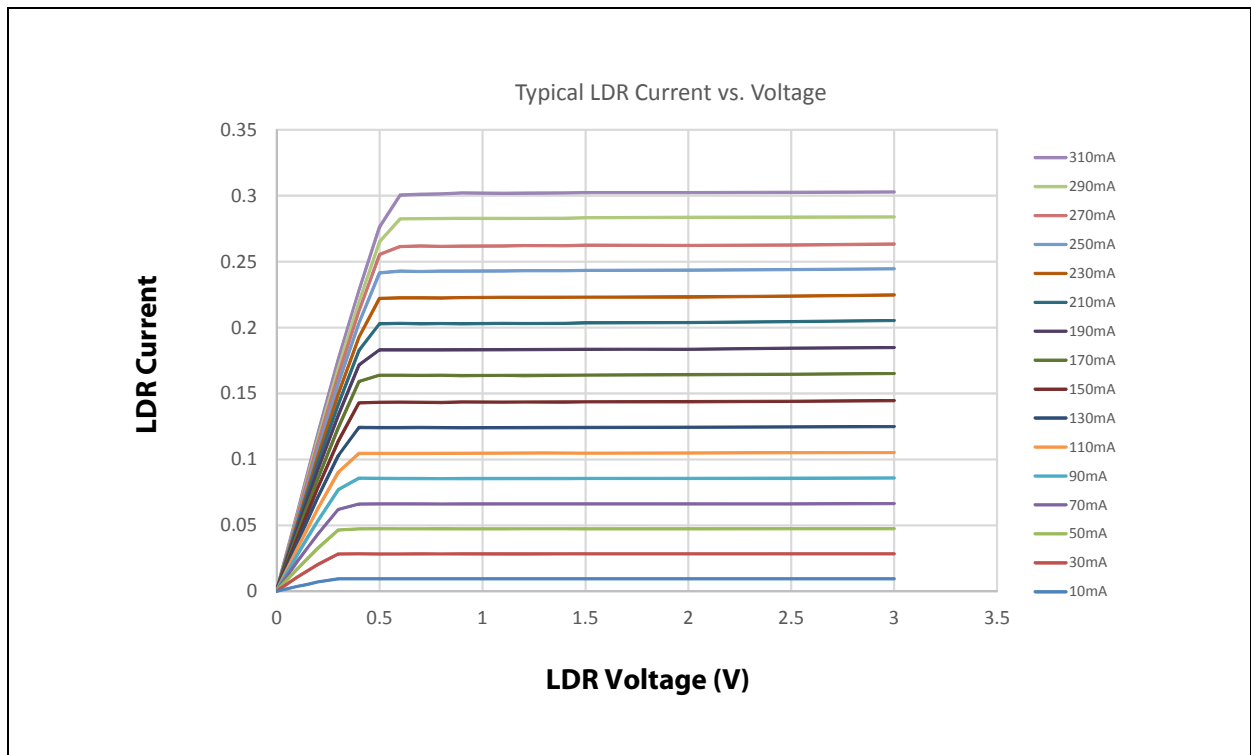

Figure 17:  
CRGB Responsivity vs. Angular Displacement



**Figure 18:**  
**Typical LDR Current vs. Voltage**



**Figure 19:**  
**Responsivity Temperature Coefficient**

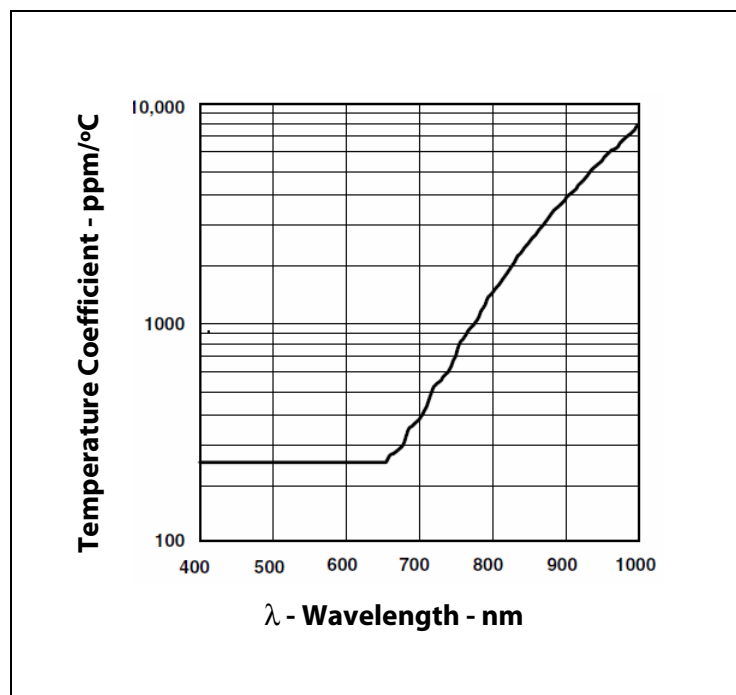

Figure 20:  
Illuminance (Lux) vs. Counts (Clear Channel)

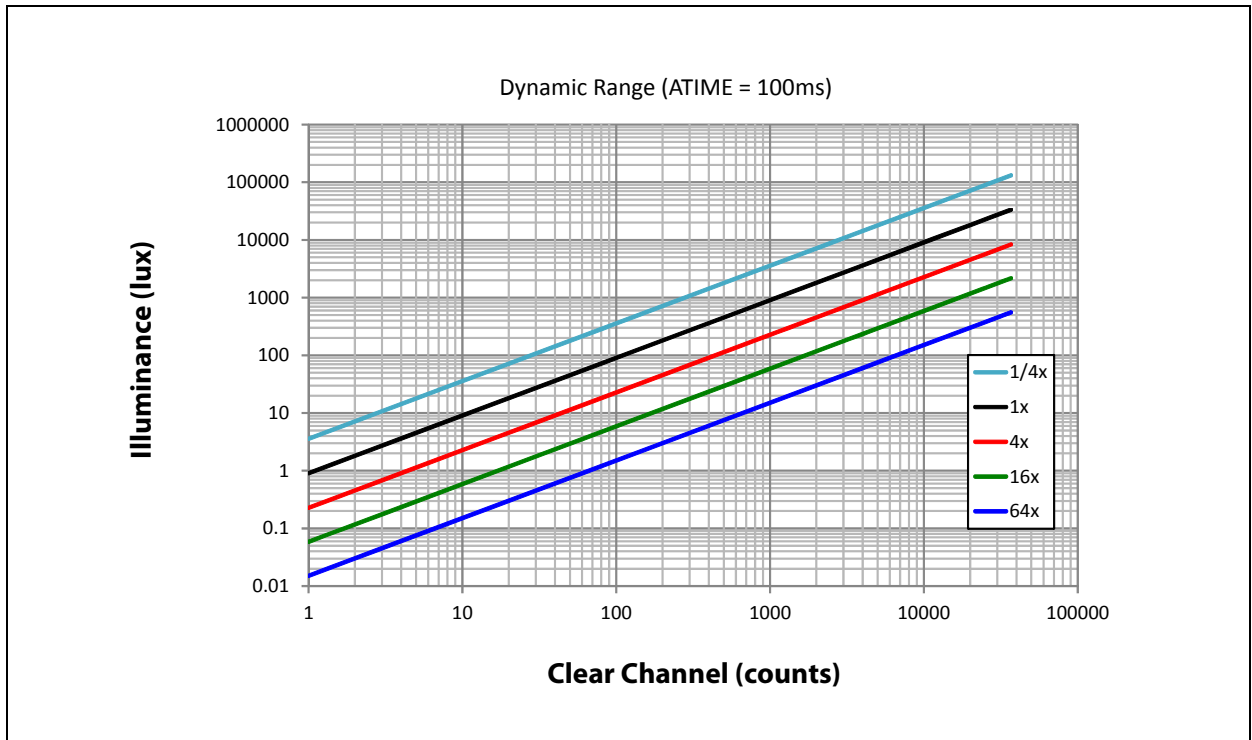
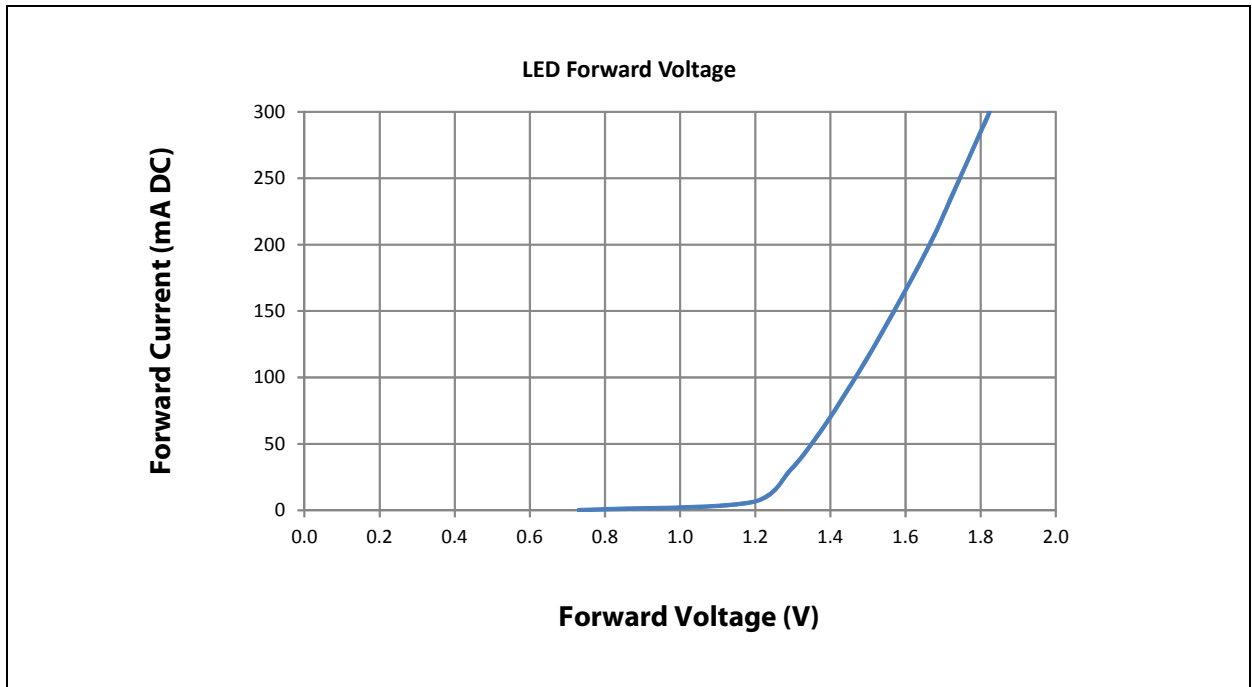

Figure 21:  
950nm LED Forward Voltage vs. Current



Note(s):

1. The voltage on the LDR pin (VLEDA – VLED FORWARD) must be sufficiently large to guarantee proper operation of the regulated current sink.

**Figure 22:**  
**Proximity Response vs. Target Distance**

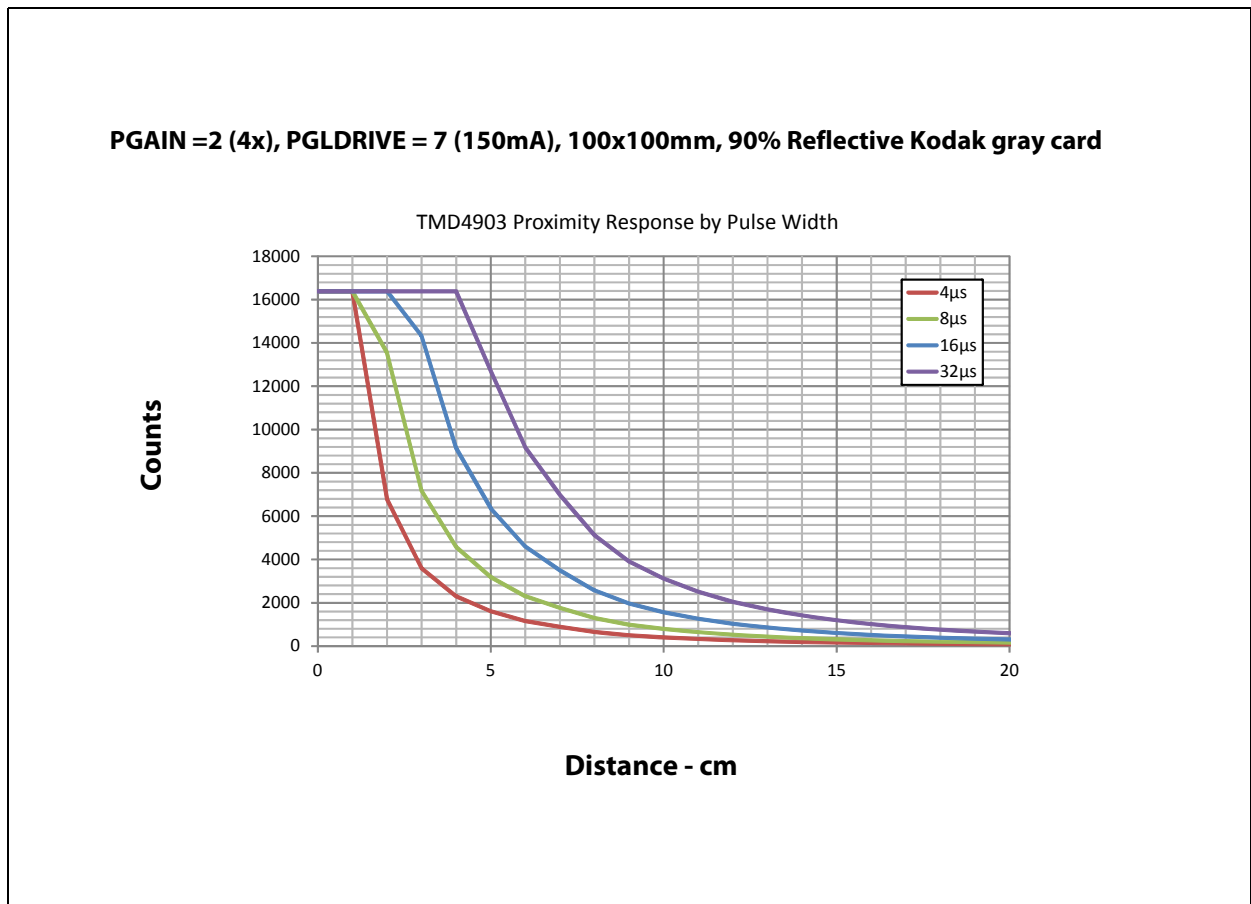



## I<sup>2</sup>C Protocol

The device uses I<sup>2</sup>C serial communication protocol for communication. The device supports 7-bit chip addressing and both standard and full-speed clock frequency modes. Read and Write transactions comply with the standard set by Philips (now NXP).

Internal to the device, an 8-bit buffer stores the register address location of the desired byte to read or write. This buffer auto-increments upon each byte transfer and is retained between transaction events (i.e. valid even after the master issues a STOP command and the I<sup>2</sup>C bus is released). During consecutive Read transactions, the future/repeated I<sup>2</sup>C Read transaction may omit the memory address byte normally following the chip address byte; the buffer retains the last register address +1.

All 16-bit fields have a latching scheme for reading and writing. In general it is recommended to use I<sup>2</sup>C bursts whenever possible, especially in this case when accessing two bytes of one logical entity. When reading these fields, the low byte must be read first, and it triggers a 16-bit latch that stores the 16-bit field. The high byte must be read immediately afterwards. When writing to these fields, the low byte must be written first, immediately followed by the high byte. Reading or writing to these registers without following these requirements will cause errors.

### I<sup>2</sup>C Write Transaction

A Write transaction consists of a START, CHIP-ADDRESSWRITE, REGISTER-ADDRESS WRITE, DATA BYTE(S), and STOP. Following each byte (9TH clock pulse) the slave places an ACKNOWLEDGE/NOT-ACKNOWLEDGE (ACK/NACK) on the bus. If NACK is transmitted by the slave, the master may issue a STOP.

### I<sup>2</sup>C Read Transaction

A Read transaction consists of a START, CHIP-ADDRESSWRITE, REGISTER-ADDRESS, RESTART, CHIP-ADDRESSREAD, DATA BYTE(S), and STOP. Following all but the final byte the master places an ACK on the bus (9TH clock pulse). Termination of the Read transaction is indicated by a NACK being placed on the bus by the master, followed by STOP.

The I<sup>2</sup>C bus protocol was developed by Philips (now NXP). For a complete description of the I<sup>2</sup>C protocol, please review the NXP I<sup>2</sup>C design specification.

**Figure 23:**  
Simplified State Diagram

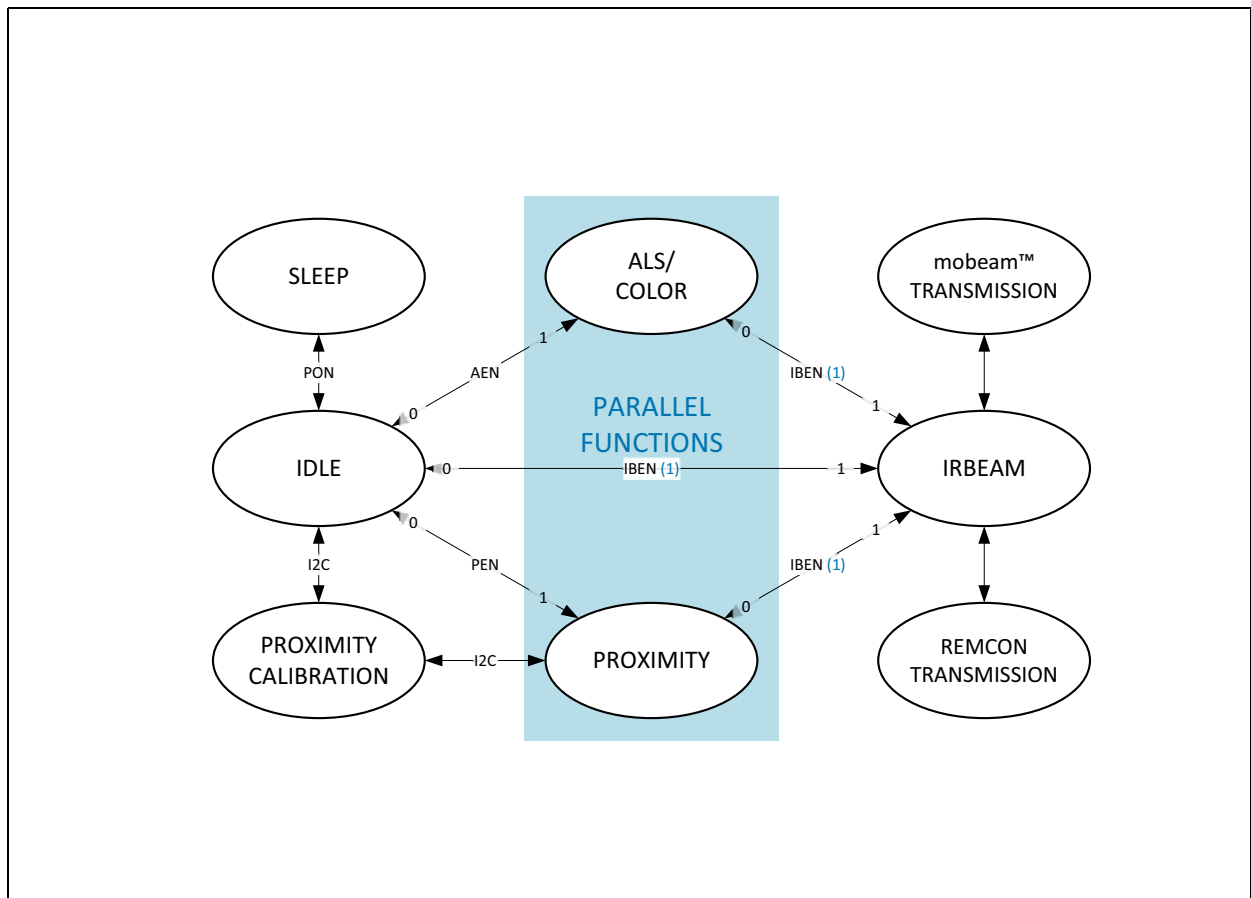
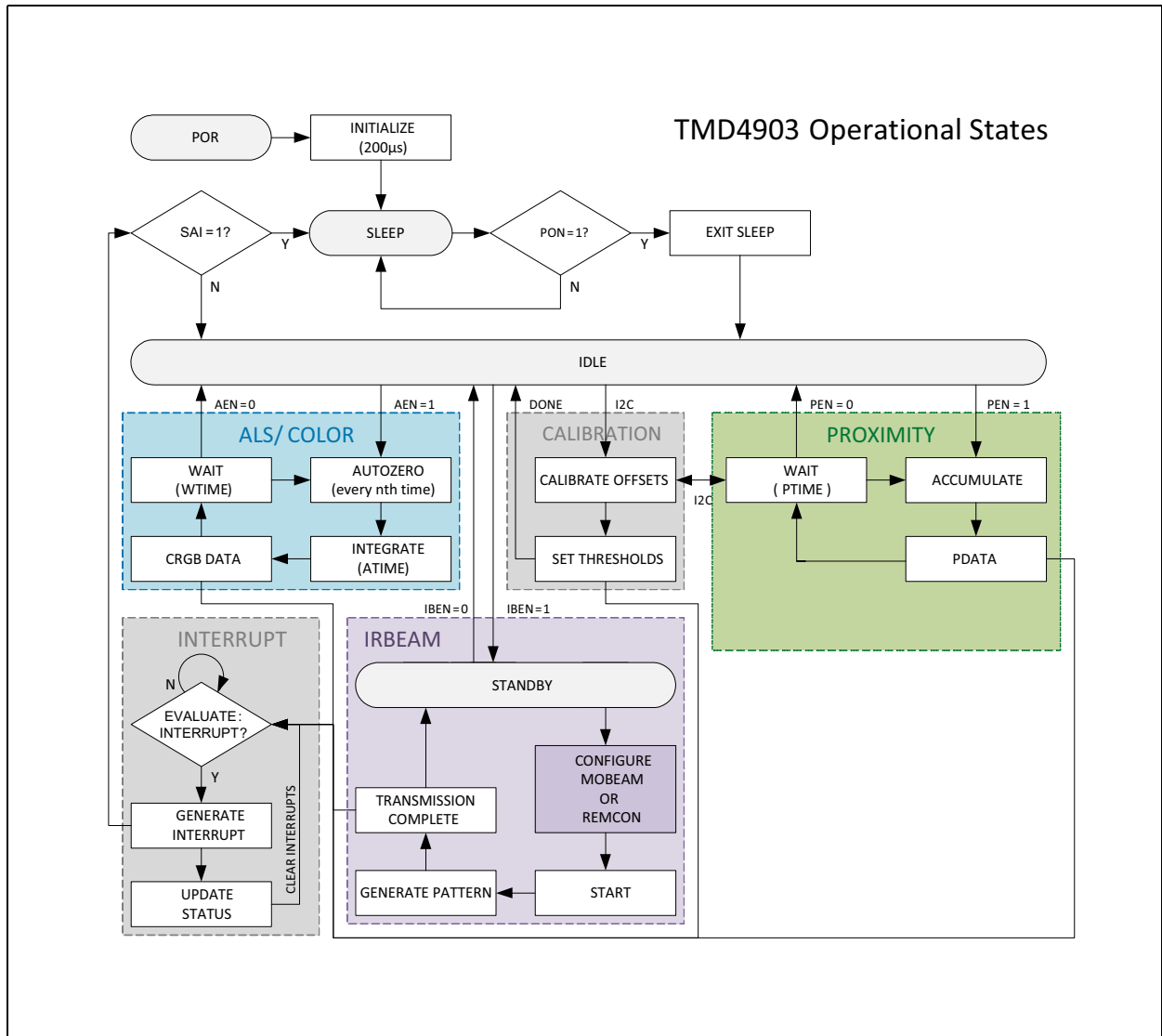

Figure 24:  
Detailed State Diagram



**Note(s):**

1. While IRBeam is enabled (IBEN = 1), PROXIMITY is disabled automatically.

## Detailed Description

Upon power-up, POR, the device initializes. During initialization (typically 200 $\mu$ s), the device will deterministically send NAK on I<sup>2</sup>C and cannot accept I<sup>2</sup>C transactions. All communication with the device must be delayed, and all outputs from the device must be ignored including interrupts. After initialization, the device enters the SLEEP state. In this operational state the internal oscillator and other circuitry are not active, resulting in ultra-low power consumption. If I<sup>2</sup>C transaction occurs during this state, the I<sup>2</sup>C core wake up temporarily to service the communication. Once the Power ON bit, PON, is enabled, the device enters the IDLE state in which the internal oscillator and attendant circuitry are active, but power consumption remains low. The first time the SLEEP state is exited and any functions are enabled (PEN | AEN | IBEN = 1) an EXIT SLEEP pause occurs followed by an immediate entry into the selected engines. If all functions are disabled (PEN = 0 & AEN = 0 & IBEN = 0), the device returns to the IDLE state.

As depicted in [Figure 23](#) and [Figure 24](#), the proximity and CRGB color sensing functions operate in parallel when enabled (PEN | AEN = 1). The IRBeam pattern generator takes priority when enabled (IBEN = 1). Proximity will not function, and ALS integration only occurs while IRBeam is in standby. In addition, when proximity or calibration is requested, it will temporarily disable the proximity function. A simplified state diagram for each function is depicted in [Figure 24](#). Each function is individually configured (e.g. Gain, ADC integration time, wait time, persistence, thresholds, etc.).

### Sleep After Interrupt Operation

If Sleep After Interrupt is enabled (SAI = 1), the state machine will enter SLEEP when non-gesture interrupts occur. However for IRBeam, the state machine remains active to continue to support this function. Entering SLEEP does not automatically change any of the register settings (e.g. PON bit is still high, but the normal operational state is over-ridden by SLEEP state). SLEEP state is terminated when the SAI bit is cleared.

## Register Description

The device is controlled and monitored by registers accessed through the I<sup>2</sup>C serial interface. These registers provide for a variety of control functions and can be read to determine results of the ADC conversions. The register set is summarized in [Figure 25](#).

**Figure 25:**  
Control Register Map

Address	Register Name	R/W	Register Function	Reset Value
0x00 – 0x7F	RAM	R/W	Volatile Storage for Pattern data	0x00
0x80	ENABLE	R/W	Enables states and interrupts	0x00
0x81	ATIME	R/W	ADC integration time	0xFF
0x82	PTIME	R/W	Proximity sample time	0x00
0x83	WTIME	R/W	ALS wait time	0xFF
0x84	AILTL	R/W	ALS interrupt low threshold low byte	0x00
0x85	AILTH	R/W	ALS interrupt low threshold high byte	0x00
0x86	AIHTL	R/W	ALS interrupt high threshold low byte	0x00
0x87	AIHTH	R/W	ALS interrupt high threshold high byte	0x00
0x88	PILTL	R/W	Proximity interrupt low threshold low byte	0x00
0x89	PILTH	R/W	Proximity interrupt high threshold high byte	0x00
0x8A	PIHTL	R/W	Proximity interrupt low threshold low byte	0x00
0x8B	PIHTH	R/W	Proximity interrupt high threshold high byte	0x00
0x8C	PERS	R/W	ALS & Proximity interrupt persistence filters	0x00
0x8D	CFG0	R/W	Configuration register zero	0xA0
0x8E	PGCFG0	R/W	Proximity pulse width and count	0x4F
0x8F	PGCFG1	R/W	Proximity gain and LED current	0x80
0x90	CFG1	R/W	Configuration register one	0x00
0x91	REVID	R	Revision ID	0x22
0x92	ID	R	Device ID	0xB8
0x93	STATUS	R	Device status register one	0x00
0x94	CDATAL	R	Clear ADC low data register	0x00
0x95	CDATAH	R	Clear ADC high data register	0x00
0x96	RDATAH	R	Red ADC low data register	0x00

Address	Register Name	R/W	Register Function	Reset Value
0x97	RDATAH	R	Red ADC high data register	0x00
0x98	GDATAH	R	Green ADC low data register	0x00
0x99	GDATAH	R	Green ADC high data register	0x00
0x9A	BDATAH	R	Blue ADC low data register	0x00
0x9B	BDATAH	R	Blue ADC high data register	0x00
0x9C	PDATAH	R	Proximity ADC low data register	0x00
0x9D	PDATAH	R	Proximity ADC high data register	0x00
0x9E	STATUS2	R	Additional device status	0x00
0x9F	CFG2	R/W	Configuration register two	0x04
0xA0	ICONFIG	R/W	IRBeam configuration register one	0x00
0xA1	ICONFIG2	R/W	IRBeam configuration register two	0x00
0xA2	ISNL	R/W	IRBeam symbol loops	0x00
0xA3	ISOFF	R/W	IRBeam delay between symbol loops	0x00
0xA4	IPNL	R/W	IRbeam packet loops	0x00
0xA5	IPOFF	R/W	IRBeam delay between packet loops	0x00
0xA6	IBT	R/W	IRBeam time period	0x00
0xA7	ISLEN	R/W	IRBeam symbol length	0x00
0xA8	ISTATUS	R	IRBeam status	0x00
0xA9	ISTART	R/W	IRBeam start transmission	0x00
0xAB	CFG3	R/W	Configuration register three	0x00
0xAC	CFG4	R/W	Configuration register four	0x07
0xAD	CFG5	R/W	Configuration register five	0x08
0xB3	STATUS3	R	Status register three	0x00
0xBC	CONTROL	R/W	Control register	0x00
0xBD	AUXID	R	Auxiliary ID	0x00
0xC0	OFFSETNL	R/W	North channel offset low byte	0x00
0xC1	OFFSETNH	R/W	North channel offset high byte	0x00
0xC2	OFFSETS	R/W	South channel offset low byte	0x00
0xC3	OFFSETSH	R/W	South channel offset high byte	0x00
0xC4	OFFSETWL	R/W	West channel offset low byte	0x00

Address	Register Name	R/W	Register Function	Reset Value
0xC5	OFFSETWH	R/W	West channel offset high byte	0x00
0xC6	OFFSETEL	R/W	East channel offset low byte	0x00
0xC7	OFFSETEH	R/W	East channel offset high byte	0x00
0xD6	AZ_CONFIG	R/W	Configure CRGB autozero frequency	0xFF
0xD7	CALIB	R/W	Start offset calibration	0x00
0xD8	CALIBCFG0	R/W	Calibration configuration register zero	0x44
0xD9	CALIBCFG1	R/W	Calibration configuration register one	0x0C
0xDD	INTENAB	R/W	Interrupt enable	0x00
0xDE	INCLEAR	R/W	Interrupt clear	0x00

### Enable Register (ENABLE 0x80)

Enable has fields that power on the device and enable the functions. Before enabling any functions, all of the bits associated with each function must be set. Changing control register values while operating may result in invalid results.

**Figure 26:**  
Enable Register

7	6	5	4	3	2	1	0
IBEN	Reserved	PIEN	AIEN	WEN	PEN	AEN	PON

Field	Bits	Description
IBEN	7	<b>IRBeam Enable.</b> When asserted, the LED driver pin (LDR) is controlled by the IRBeam state machine. Proximity is suppressed. ALS continues in the background except when IBUSY = 1 (ISTATUS register).
Reserved	6	<b>Reserved.</b> Bit must be set to 0.
PIEN	5	<b>Proximity Interrupt Enable.</b> When asserted permits proximity interrupts to be generated, subject to the proximity thresholds and persistence filter.
AIEN	4	<b>ALS Interrupt Enable.</b> When asserted permits ALS interrupts to be generated, subject to the ALS thresholds and persistence filter.
WEN	3	<b>Wait Enable.</b> This bit activates the wait feature. Writing a 1 activates the wait timer. Writing a 0 disables the wait timer.
PEN	2	<b>Proximity Enable.</b> This bit activates the proximity function. Writing a 1 enables proximity. Writing a 0 disables proximity.
AEN	1	<b>ALS Enable.</b> This bit activates the ALS/Color functionality. Writing a 1 enables ALS/Color. Writing a 0 disables ALS/Color.
PON	0	<b>Power ON.</b> This bit activates the internal oscillator to permit the timers and ADC channels to operate. Writing a 1 activates the oscillator. Writing a 0 disables the oscillator and clears IBEN, PEN, and AEN. Only set this bit after all other registers have been initialized by the host.



**ALS Integration Time Register (ATIME 0x81)**

**Figure 27:**  
ALS Integration Time Register

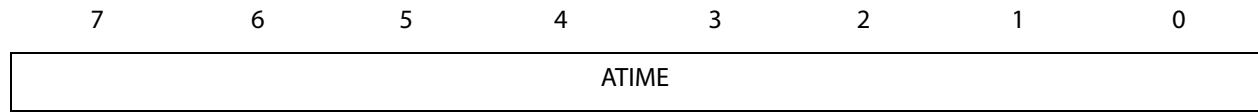

Field	Bits	Description		
ATIME	7:0	<p><b>ALS Integration Time.</b> Sets the internal integration time of ALS/Color analog to digital converters in increments of 2.78ms. The power on reset value is 0xFF. The ADC maximum count (or saturation) value depends on the integration time. It is the lesser of either:                      65535 (16-bit saturation) or                      The result of equation: <math>Count_{MAX} = 1024 \times CYCLES</math></p>		
		VALUE	INTEGRATION TIME	MAX COUNTS
		0xFF	2.78ms	1024
		0xF6	27.8ms	10240
		0xDC	100ms	36864
		...	$2.78ms \times (256 - ATIME)$	...
		0xC0	178ms	65535
		0x00	711ms	65535

### Proximity Sample Time Register (PTIME 0x82)

**Figure 28:**  
Proximity Sample Time Register

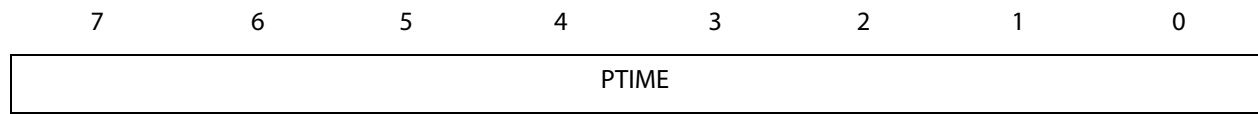

Field	Bits	Description		
PTIME	7:0	<b>Proximity Sample Time.</b> Sets the proximity sample rate. The power on reset value is 0x00. Proximity is executed once for each sample time.		
		<b>VALUE</b>	<b>SAMPLE TIME</b>	<b>FREQUENCY</b>
		0x00	2.78ms	360Hz
		0x01	5.56ms	180Hz
		0x03	11.1ms	90Hz
		0x23	100ms	10Hz
		...	<i>2.78ms X (PTIME +1)</i>	<i>1/Proximity Sample Time</i>
		0xFF	711ms	1.41Hz