



Chipsmall Limited consists of a professional team with an average of over 10 year of expertise in the distribution of electronic components. Based in Hongkong, we have already established firm and mutual-benefit business relationships with customers from,Europe,America and south Asia,supplying obsolete and hard-to-find components to meet their specific needs.

With the principle of “Quality Parts,Customers Priority,Honest Operation,and Considerate Service”,our business mainly focus on the distribution of electronic components. Line cards we deal with include Microchip,ALPS,ROHM,Xilinx,Pulse,ON,Everlight and Freescale. Main products comprise IC,Modules,Potentiometer,IC Socket,Relay,Connector.Our parts cover such applications as commercial,industrial, and automotives areas.

We are looking forward to setting up business relationship with you and hope to provide you with the best service and solution. Let us make a better world for our industry!



Contact us

Tel: +86-755-8981 8866 Fax: +86-755-8427 6832

Email & Skype: info@chipsmall.com Web: www.chipsmall.com

Address: A1208, Overseas Decoration Building, #122 Zhenhua RD., Futian, Shenzhen, China





**PT100 RTD
Evaluation Board
User's Guide**

Note the following details of the code protection feature on Microchip devices:

- Microchip products meet the specification contained in their particular Microchip Data Sheet.
- Microchip believes that its family of products is one of the most secure families of its kind on the market today, when used in the intended manner and under normal conditions.
- There are dishonest and possibly illegal methods used to breach the code protection feature. All of these methods, to our knowledge, require using the Microchip products in a manner outside the operating specifications contained in Microchip's Data Sheets. Most likely, the person doing so is engaged in theft of intellectual property.
- Microchip is willing to work with the customer who is concerned about the integrity of their code.
- Neither Microchip nor any other semiconductor manufacturer can guarantee the security of their code. Code protection does not mean that we are guaranteeing the product as "unbreakable."

Code protection is constantly evolving. We at Microchip are committed to continuously improving the code protection features of our products. Attempts to break Microchip's code protection feature may be a violation of the Digital Millennium Copyright Act. If such acts allow unauthorized access to your software or other copyrighted work, you may have a right to sue for relief under that Act.

Information contained in this publication regarding device applications and the like is provided only for your convenience and may be superseded by updates. It is your responsibility to ensure that your application meets with your specifications. MICROCHIP MAKES NO REPRESENTATIONS OR WARRANTIES OF ANY KIND WHETHER EXPRESS OR IMPLIED, WRITTEN OR ORAL, STATUTORY OR OTHERWISE, RELATED TO THE INFORMATION, INCLUDING BUT NOT LIMITED TO ITS CONDITION, QUALITY, PERFORMANCE, MERCHANTABILITY OR FITNESS FOR PURPOSE. Microchip disclaims all liability arising from this information and its use. Use of Microchip devices in life support and/or safety applications is entirely at the buyer's risk, and the buyer agrees to defend, indemnify and hold harmless Microchip from any and all damages, claims, suits, or expenses resulting from such use. No licenses are conveyed, implicitly or otherwise, under any Microchip intellectual property rights.

Trademarks

The Microchip name and logo, the Microchip logo, Accuron, dsPIC, KEELOQ, KEELOQ logo, microID, MPLAB, PIC, PICmicro, PICSTART, PRO MATE, rPIC and SmartShunt are registered trademarks of Microchip Technology Incorporated in the U.S.A. and other countries.

AmpLab, FilterLab, Linear Active Thermistor, Migratable Memory, MXDEV, MXLAB, SEEVAL, SmartSensor and The Embedded Control Solutions Company are registered trademarks of Microchip Technology Incorporated in the U.S.A.

Analog-for-the-Digital Age, Application Maestro, CodeGuard, dsPICDEM, dsPICDEM.net, dsPICworks, dsSPEAK, ECAN, ECONOMONITOR, FanSense, FlexROM, fuzzyLAB, In-Circuit Serial Programming, ICSP, ICEPIC, Mindi, MiWi, MPASM, MPLAB Certified logo, MPLIB, MPLINK, PICkit, PICDEM, PICDEM.net, PICLAB, PICTail, PowerCal, PowerInfo, PowerMate, PowerTool, REAL ICE, rfLAB, Select Mode, Smart Serial, SmartTel, Total Endurance, UNI/O, WiperLock and ZENA are trademarks of Microchip Technology Incorporated in the U.S.A. and other countries.

SQTP is a service mark of Microchip Technology Incorporated in the U.S.A.

All other trademarks mentioned herein are property of their respective companies.

© 2007, Microchip Technology Incorporated, Printed in the U.S.A., All Rights Reserved.

 Printed on recycled paper.

**QUALITY MANAGEMENT SYSTEM
CERTIFIED BY DNV
== ISO/TS 16949:2002 ==**

Microchip received ISO/TS-16949:2002 certification for its worldwide headquarters, design and wafer fabrication facilities in Chandler and Tempe, Arizona; Gresham, Oregon and design centers in California and India. The Company's quality system processes and procedures are for its PIC® MCUs and dsPIC® DSCs, KEELOQ® code hopping devices, Serial EEPROMs, microperipherals, nonvolatile memory and analog products. In addition, Microchip's quality system for the design and manufacture of development systems is ISO 9001:2000 certified.



PT100 RTD EVALUATION BOARD USER'S GUIDE

Table of Contents

Preface	1
Introduction.....	1
Document Layout	1
Conventions Used in this Guide	2
Recommended Reading.....	3
The Microchip Web Site	3
Customer Support	4
Document Revision History	4
Chapter 1. Product Overview	5
1.1 Introduction	5
1.2 What is the PT100 RTD Evaluation Board?	5
1.3 What the PT100 RTD Evaluation Board Kit Includes	5
Chapter 2. Installation and Operation	7
2.1 Introduction	7
2.2 Features	7
2.3 Getting Started	8
2.4 Functional Description	10
Appendix A. Schematic and Layouts	13
A.1 Introduction	13
A.2 Board Schematic - Page 1	14
A.3 Board Schematic - Page 2	15
A.4 Board - Top Silk-screen Layer	16
A.5 Board - Top Layer	16
A.6 Board - Bottom Silk	17
A.7 Board - Bottom Layer	17
Appendix B. Bill Of Materials (BOM)	19
Worldwide Sales and Service	22

PT100 RTD Evaluation Board User's Guide

NOTES:

Preface

NOTICE TO CUSTOMERS

All documentation becomes dated, and this manual is no exception. Microchip tools and documentation are constantly evolving to meet customer needs, so some actual dialogs and/or tool descriptions may differ from those in this document. Please refer to our web site (www.microchip.com) to obtain the latest documentation available.

Documents are identified with a “DS” number. This number is located on the bottom of each page, in front of the page number. The numbering convention for the DS number is “DSXXXXA”, where “XXXX” is the document number and “A” is the revision level of the document.

For the most up-to-date information on development tools, see the MPLAB® IDE on-line help. Select the Help menu, and then Topics to open a list of available on-line help files.

INTRODUCTION

This chapter contains general information that will be useful to know before using the PT100 RTD Evaluation Board. Items discussed in this chapter include:

- Document Layout
- Conventions Used in this Guide
- Recommended Reading
- The Microchip Web Site
- Customer Support
- Document Revision History

DOCUMENT LAYOUT

This document describes how to use the PT100 RTD Evaluation Board as a development tool. The manual layout is as follows:

- **Chapter 1. “Product Overview”** – Important information about the PT100 RTD Evaluation Board.
- **Chapter 2. “Installation and Operation”** – This chapter includes a detailed description of each function of the demo board and instructions for how to begin using the board.
- **Appendix A. “Schematic and Layouts”** – Shows the schematic and layout diagrams for the PT100 RTD Evaluation Board.
- **Appendix B. “Bill Of Materials (BOM)”** – Lists the parts used to build the PT100 RTD Evaluation Board.

PT100 RTD Evaluation Board User's Guide

CONVENTIONS USED IN THIS GUIDE

This manual uses the following documentation conventions:

DOCUMENTATION CONVENTIONS

Description	Represents	Examples
Arial font:		
Italic characters	Referenced books	<i>MPLAB[®] IDE User's Guide</i>
	Emphasized text	...is the <i>only</i> compiler...
Initial caps	A window	the Output window
	A dialog	the Settings dialog
	A menu selection	select Enable Programmer
Quotes	A field name in a window or dialog	"Save project before build"
Underlined, italic text with right angle bracket	A menu path	<u><i>File>Save</i></u>
Bold characters	A dialog button	Click OK
	A tab	Click the Power tab
N'Rnnnn	A number in verilog format, where N is the total number of digits, R is the radix and n is a digit.	4'b0010, 2'hF1
Text in angle brackets < >	A key on the keyboard	Press <Enter>, <F1>
Courier New font:		
Plain Courier New	Sample source code	#define START
	Filenames	autoexec.bat
	File paths	c:\mcc18\h
	Keywords	_asm, _endasm, static
	Command-line options	-Opa+, -Opa-
	Bit values	0, 1
	Constants	0xFF, 'A'
Italic Courier New	A variable argument	<i>file.o</i> , where <i>file</i> can be any valid filename
Square brackets []	Optional arguments	mcc18 [options] <i>file</i> [options]
Curly brackets and pipe character: { }	Choice of mutually exclusive arguments; an OR selection	errorlevel {0 1}
Ellipses...	Replaces repeated text	var_name [, var_name...]
	Represents code supplied by user	void main (void) { ... }

RECOMMENDED READING

This user's guide describes how to use the PT100 RTD Evaluation Board. The following Microchip documents are available on our web site (www.microchip.com) and recommended as supplemental reference resources.

MCP6S26 Data Sheet, “Single-Ended, Rail-to-Rail I/O, Low Gain PGA” (DS21117)

This data sheet provides detailed information regarding the MCP6S26 device.

MCP3301 Data Sheet, “13-Bit Differential Input, Low Power A/D Converter w/SPI Serial Interface” (DS21700)

This data sheet provides detailed information regarding the MCP3301 device.

MCP602X Data Sheet, “Rail-to-Rail Input/Output, 10 MHz Op Amps” (DS21685)

This data sheet provides detailed information regarding the MCP602X devices.

MCP41010 Data Sheet, “Single/Dual Digital Potentiometer with SPI Interface” (DS11195)

This data sheet provides detailed information regarding the MCP41XXX devices.

PIC18F2455/2550/4455/4550 Data Sheet, “28/40/44-Pin, High-Performance, Enhanced Flash, USB Microcontrollers with nanoWatt Technology” (DS39632)

This data sheet provides detailed information regarding the PIC18F2455/2550/4455/4550 devices.

TC1070/TC1071/TC1187 Data Sheet, “50 mA, 100 mA, and 150 mA Adjustable CMOS LDOs w/Shutdown” (DS21353)

This data sheet provides detailed information regarding the TC1070/TC1071/TC1187 devices.

THE MICROCHIP WEB SITE

Microchip provides online support via our web site at www.microchip.com. This web site is used as a means to make files and information easily available to customers. Accessible by using your favorite internet browser, the web site contains the following information:

- **Product Support** – Data sheets and errata, application notes and sample programs, design resources, user's guides and hardware support documents, latest software releases and archived software
- **General Technical Support** – Frequently Asked Questions (FAQs), technical support requests, online discussion groups, Microchip consultant program member listing
- **Business of Microchip** – Product selector and ordering guides, latest Microchip press releases, listing of seminars and events, listings of Microchip sales offices, distributors and factory representatives

PT100 RTD Evaluation Board User's Guide

CUSTOMER SUPPORT

Users of Microchip products can receive assistance through several channels:

- Distributor or Representative
- Local Sales Office
- Field Application Engineer (FAE)
- Technical Support
- Development Systems Information Line

Customers should contact their distributor, representative or field application engineer for support. Local sales offices are also available to help customers. A listing of sales offices and locations is included in the back of this document.

Technical support is available through the web site at: <http://support.microchip.com>

DOCUMENT REVISION HISTORY

Revision B (December 2007)

- Changed Information Related to the GUI.
- Updated Figure 2-3 and Figure 2-6.
- Updated **Section 2.3.2 “Software Setup”**.
- Add disclaimer to Bill of Materials regarding RoHS-Compliant part numbers.

Revision A (May 2006)

- Initial Release of this Document.

Chapter 1. Product Overview

1.1 INTRODUCTION

This chapter provides an overview of the PT100 RTD Evaluation Board and covers the following topics:

- What is the PT100 RTD Evaluation Board?
- What the PT100 RTD Evaluation Board kit includes.

1.2 WHAT IS THE PT100 RTD EVALUATION BOARD?

The PT100 RTD Evaluation Board demonstrates how to bias a Resistive Temperature Detector (RTD) and accurately measure temperature. Up to two RTDs can be connected. The RTDs are biased using constant current source and the output voltage is scaled using a difference amplifier. In addition to the difference amplifier, a multiple input channel Programmable Gain Amplifier (PGA) MCP6S26 is used to digitally switch between RTDs and increase the scale up to 32 times.

The output of the difference amplifier is connected to a 12-bit differential Analog-to-Digital Converter (ADC) MCP3301. The ADC outputs serial data to the PIC18F2550 using a Serial Peripheral Interface (SPI). The data is transmitted to a PC using a USB interface.

A PC Software Graphical User Interface (GUI) is used to acquire the data. The acquired data is graphed as a real-time stripchart display. In addition, the user can select input channels, acquisition interval, and stripchart display buffer size.

1.3 WHAT THE PT100 RTD EVALUATION BOARD KIT INCLUDES

This PT100 RTD Evaluation Board Kit includes:

- The PT100 RTD Evaluation Board (102-00096)
- PIC18F2550 Firmware (USB)
- PC Software GUI
- Analog and Interface Products Demonstration Boards CD-ROM (DS21912)
 - PT100 RTD Evaluation Board User's Guide (DS51607)
- Mini-USB Cable

PT100 RTD Evaluation Board User's Guide

NOTES:

Chapter 2. Installation and Operation

2.1 INTRODUCTION

The PT100 RTD Evaluation Board allows the user to evaluate Microchip's solution to accurately measure temperature using RTD. When biasing RTDs to measure temperature, self-heat due to power dissipation has to be considered. RTD resistance availability typically ranges from 100 Ω to 5,000 Ω . In order to measure the output voltage across the RTD over a wide temperature range, the biasing current has to be relatively high. This higher current causes more power dissipation through heat and skews the temperature reading. Microchip's solution to this challenge is to use the MCP6S26 Programmable Gain Amplifier (PGA) to increase the sensor dynamic output range and increase measurement resolution while significantly reducing the biasing current magnitude.

This board consists of a surface mount RTD to measure the PCB temperature and an external RTD connector. In addition, the user can connect and measure an external leaded RTD (2, 3, or 4-Wire) and configure the corresponding jumper to remotely measure temperature. The multiple input channel PGA adds gain programmability into the analog circuit. The multiple input channels are used to switch between RTDs and the gain is used to increase the sensor dynamic range.

The PGA output is connected to a differential amplifier circuit which allows the user to scale the sensor output. The differential output is digitized using an MCP3301 12-bit differential analog-to-digital converter. The data is transmitted to the PC using the USB interface. A PC Software Graphical User Interface (GUI) is used to obtain and display the data in real-time.

2.2 FEATURES

The PT100 RTD Evaluation Board has the following features:

- A surface mount PT100 RTD
- External (2, 3, or 4-wire) RTD connector
- Gain and input channel programmability using MCP6S26 PGA
- MCP3301 12-Bit + sign ADC
- MCP41010 10 k Ω Digital Potentiometer
- PIC18F2550 PICmicro[®] Microcontroller
- USB interface to PC
- PC Software GUI

PT100 RTD Evaluation Board User's Guide

2.3 GETTING STARTED

This section describes how to quickly configure the PT100 RTD Evaluation Board. A simplified block diagram of the configuration is provided in Figure 2-1.

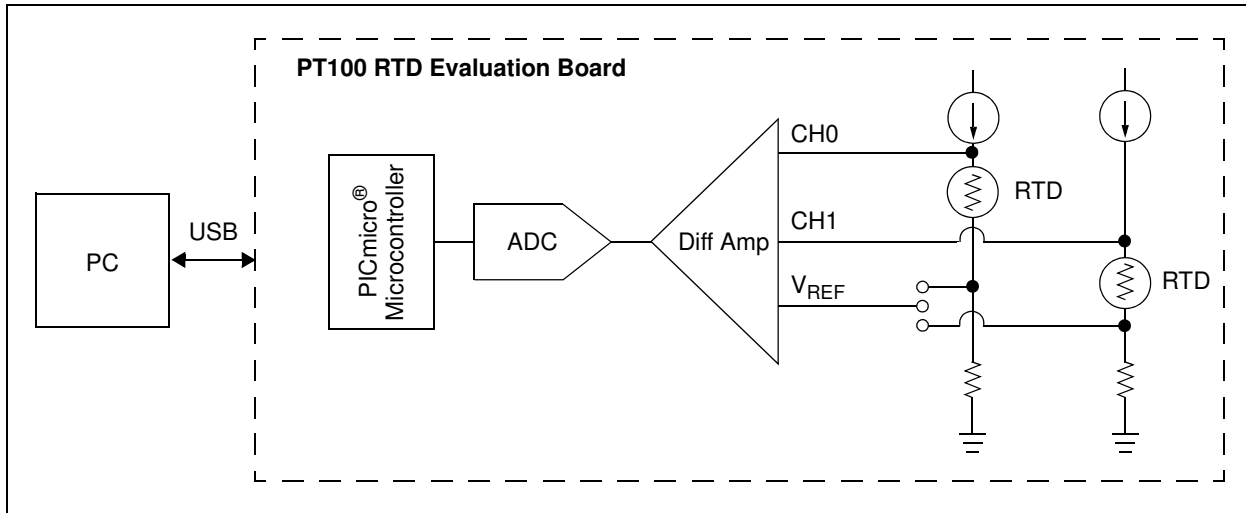

FIGURE 2-1: PT100 RTD Evaluation Board Simplified Block Diagram.

2.3.1 Hardware Setup

1. Connect the USB cable to PC.
2. To measure PCB temperature, connect JP1 to **Local RTD** position and JP2 to RTD position.

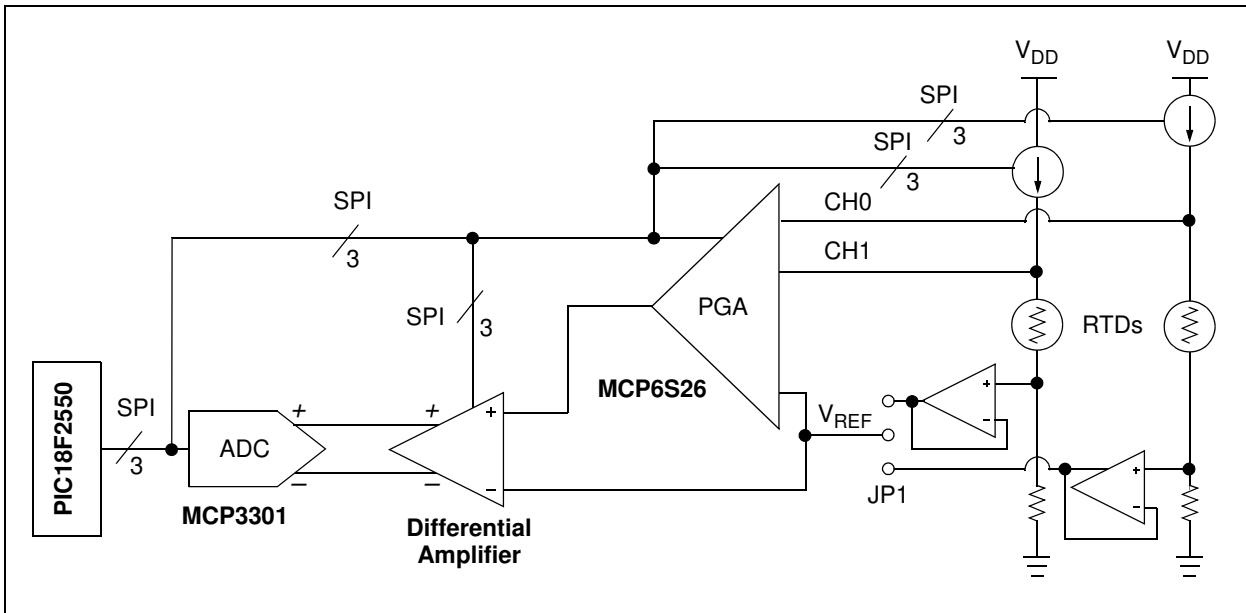

FIGURE 2-2: Simplified PT100 RTD Evaluation Board Schematic.

2.3.2 Software Setup

1. Once the USB connection is secure, start the *PT100RTD ThermalManagement.EXE* file and select **Enable Macro**. When the software starts, the Configuration window will be displayed, as shown in Figure 2-3.

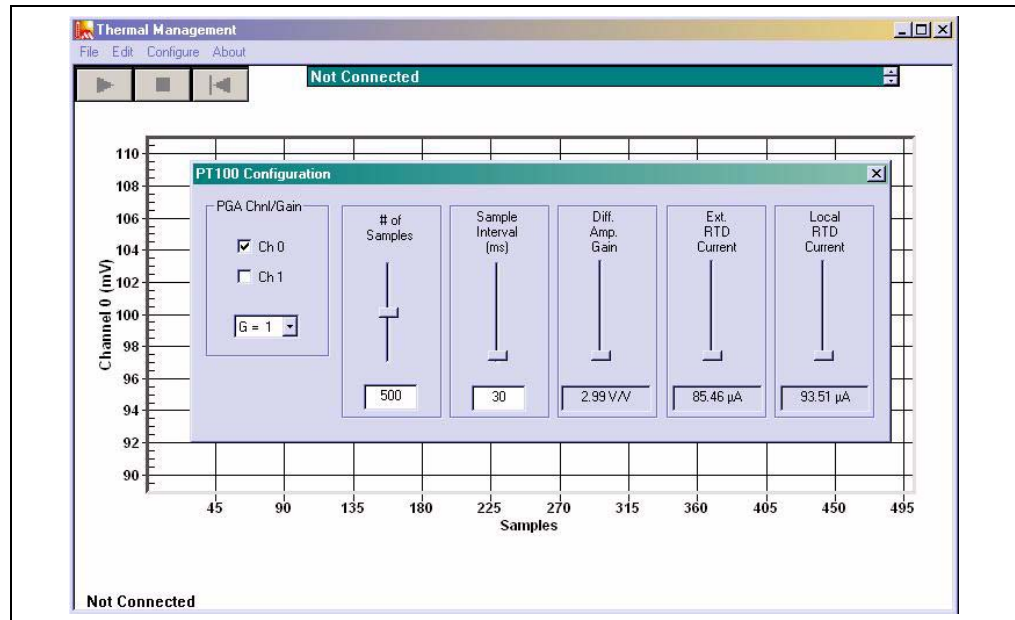

FIGURE 2-3: PC Software GUI.

2. Select **Enable/Disable** for CH0 or CH1 (Channel 0 and Channel 1, respectively).
3. Select **PGA gain**, **ADC sampling rate**, and **sampling buffer size** for the stripchart display.
4. Use the scroll bar to adjust the differential amplifier gain and Remote or Local RTD bias currents.
5. Click **start** to start acquisition, **stop** to stop acquisition. **Reset** to Clear buffer.
6. Adjust the digital potentiometer positions to select the differential amplifier gain and trim the current sources for the local and external RTDs.
7. Double-click the chart. The Chart Configuration window will be displayed.

PT100 RTD Evaluation Board User's Guide

2.4 FUNCTIONAL DESCRIPTION

2.4.1 The PT100 RTD Evaluation Board

The PT100 RTD Evaluation Board uses surface mount RTD to measure temperature. An external 2, 3, or 4-wire PT100 RTD can also be connected to measure temperature in remote locations. The RTDs are biased using a constant current source. In order to reduce self-heat due to power dissipation, the current magnitude is relatively low. The small voltage across the RTD is amplified using the MCP6S26 PGA. The PGA allows the user to digitally program the amplifier gain and increase the sensor output range. The output of the PGA is scaled using a differential amplifier. The differential amplifier drives a 12-Bit + sign differential ADC, MCP3301. The digital data is read using PIC18F2550 and transmitted to PC using a USB interface.

2.4.1.1 THE RTD BIASING CONSTANT CURRENT SOURCE

The constant current source uses a reference voltage, one amplifier, and a PNP transistor, as shown in Figure 2-4.

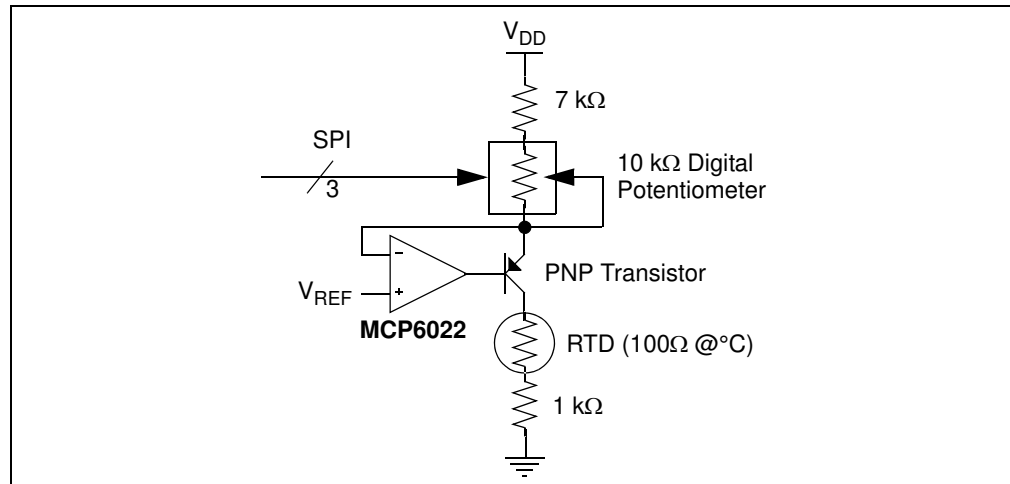

FIGURE 2-4: Constant Current Source.

The amplifier maintains constant voltage at the transistor emitter terminal. Therefore, the emitter and collector currents are constant. The collector current biases the RTD. The biasing current can be fine tuned by adjusting the 10 kΩ digital potentiometer using the GUI. A 100Ω, 0.1% resistor is available for system calibration at 0°C (RTD resistance at 0°C is 100Ω). This resistor can be jumped using JP1.

When connecting an external PT100 RTD, connect JP2 to **External Position**.

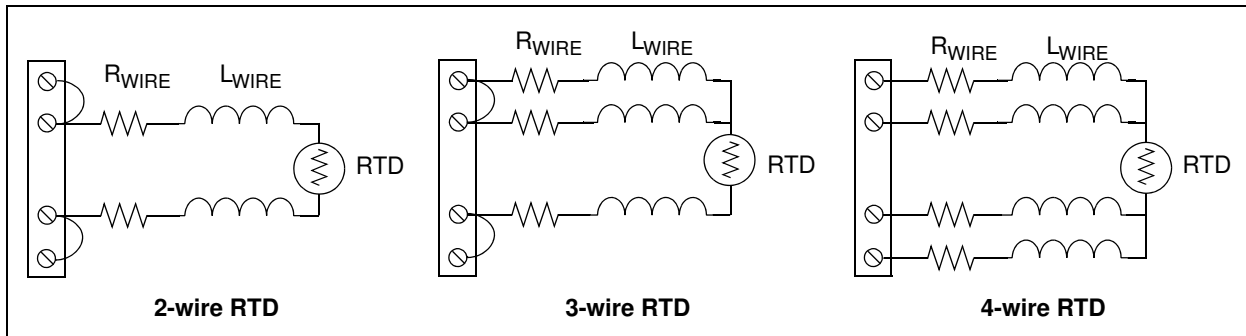

FIGURE 2-5: External RTD Connections.

2.4.1.2 RTD SIGNAL CHAIN

The PGA is used to amplify the small voltage across the RTD. The reference input pin of the PGA is connected to the RTD negative terminal and Channel 0 and Channel 1 are connected to the positive terminals of each RTD. This allows only the voltage across the sensor to be amplified. The PGA has a gain error of $\pm 1\%$ (max.) for gains greater than 1 V/V. Refer to the datasheet (DS21685) for details.

The RTD negative terminal and the PGA output are connected to the differential amplifier. The differential amplifier scales the PGA output. The difference amplifier gain is shown in Equation 2-1.

EQUATION 2-1: DIFFERENCE AMPLIFIER GAIN

$$G = 1 + \left(\frac{2 \times R_F}{R_G + 20\Omega} \right)$$

Where:

$R_F = 10 \text{ k}\Omega$

$R_G = 10 \text{ k}\Omega$ Digital Potentiometer

2.4.1.3 THE GRAPHICAL USER INTERFACE

The GUI uses the USB port to communicate with the PIC18F2550.

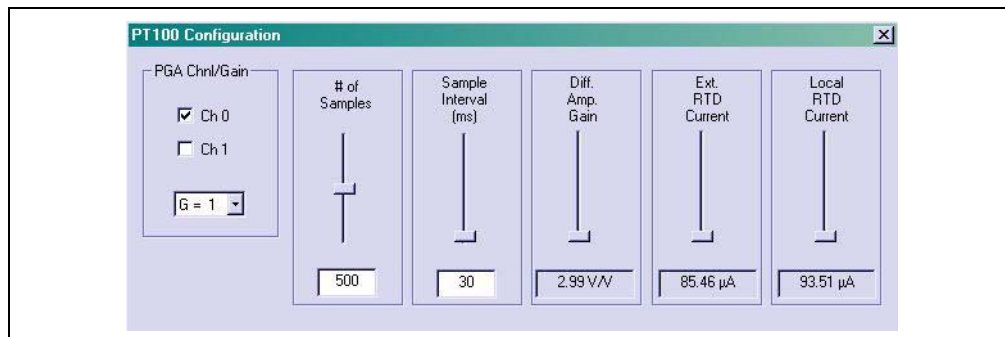

FIGURE 2-6: Hardware Status

When **start** is clicked, the macro double checks hardware availability before starting the acquisition.

All user options such as **Sampling time**, **Stripchart buffer size**, **Digi. Pot Positions**, or **PGA Chn/Gain** setup can be changed during acquisition.

PT100 RTD Evaluation Board User's Guide

NOTES:



PT100 RTD EVALUATION BOARD USER'S GUIDE

Appendix A. Schematic and Layouts

A.1 INTRODUCTION

This appendix contains the following schematics and layouts for the PT100 RTD Evaluation Board:

- Board Schematic
- Board - Top Layer
- Board - Silk-screen Layer
- Board - Bottom Layer

PT100 RTD Evaluation Board User's Guide

A.2 BOARD SCHEMATIC - PAGE 1

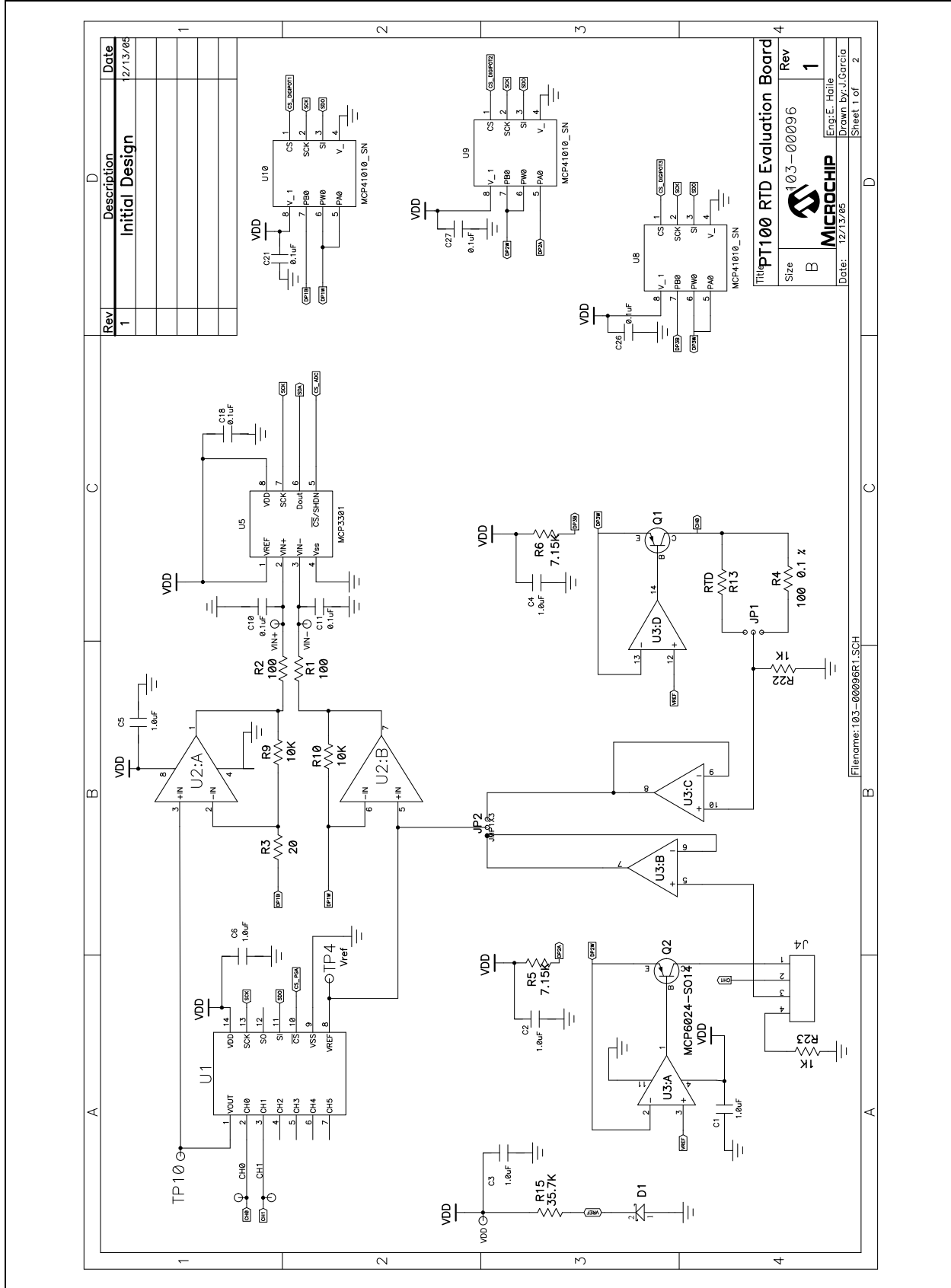

A.3 BOARD SCHEMATIC - PAGE 2

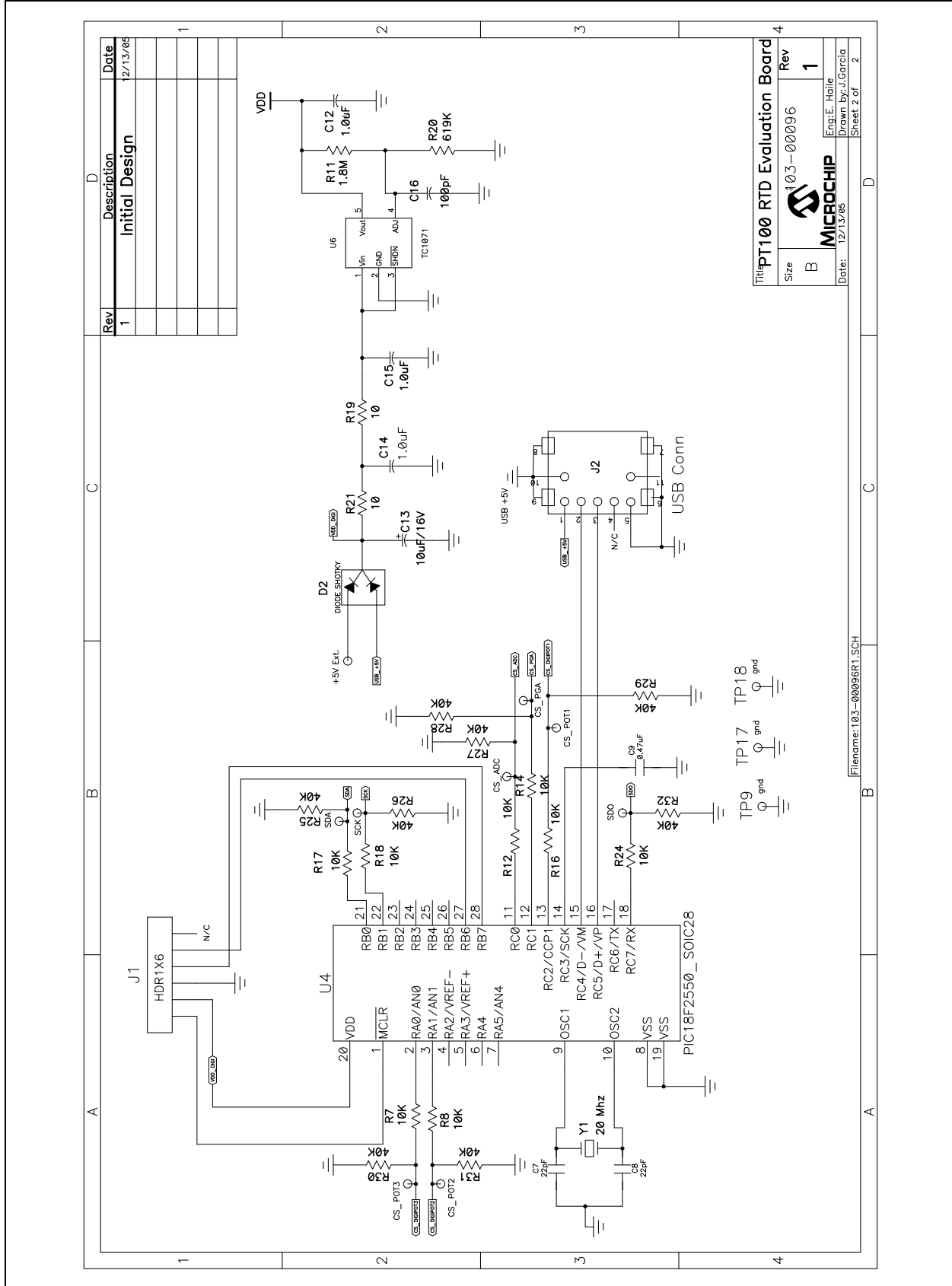

PT100 RTD Evaluation Board User's Guide

A.4 BOARD - TOP SILK-SCREEN LAYER

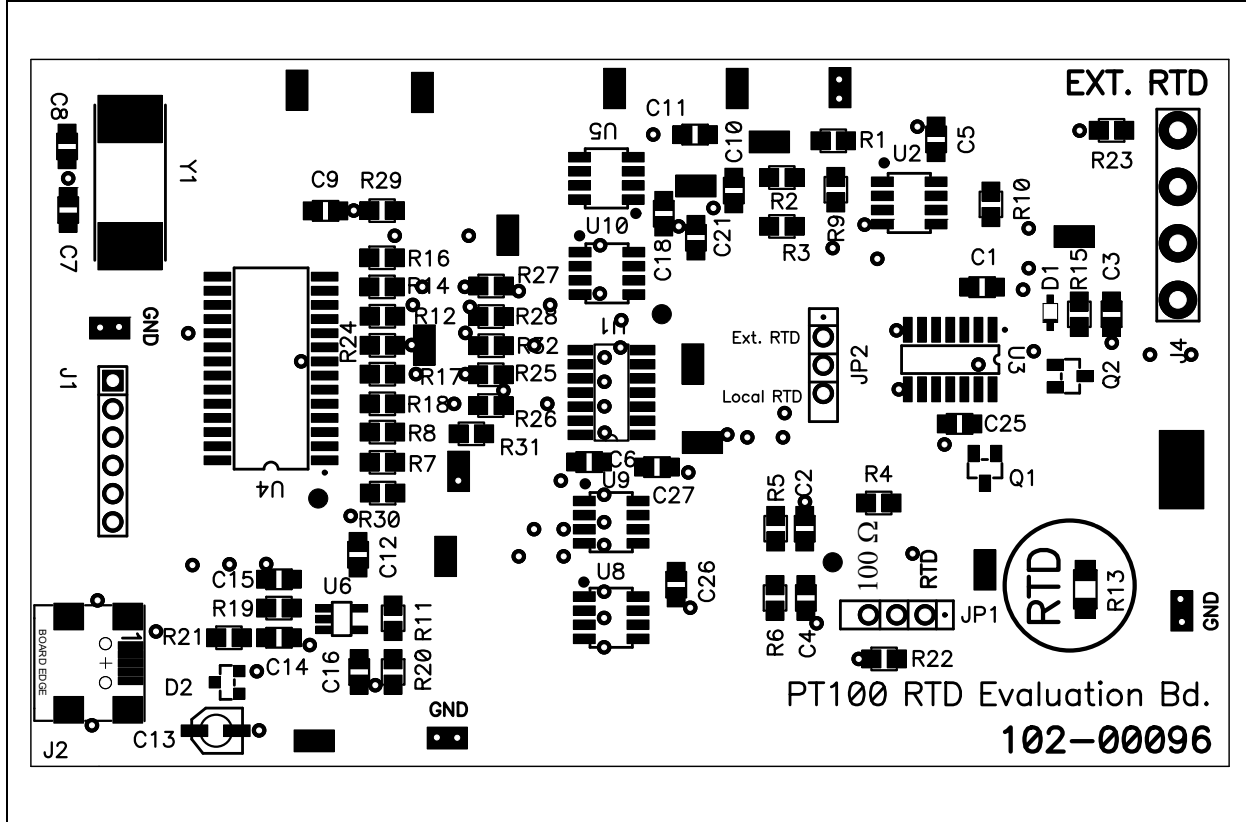

A.5 BOARD - TOP LAYER

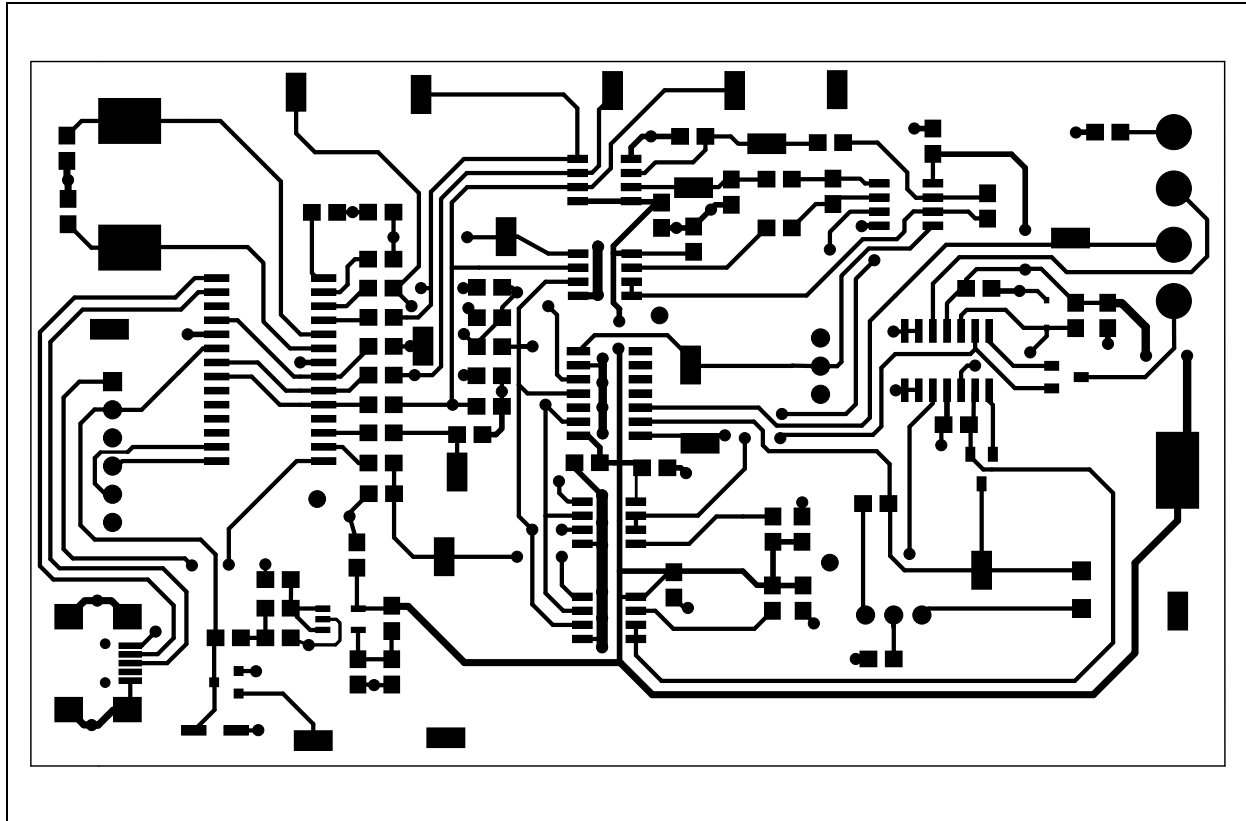

PT100 RTD Evaluation Board User's Guide

NOTES:

Appendix B. Bill Of Materials (BOM)
TABLE B-1: BILL OF MATERIALS

Qty	Reference	Description	Manufacturer	Part Number
10	C1, C2, C3, C4, C5, C6, C12, C14, C15, C16	CAP 1.0UF 10V CERAMIC X7R 0805	Kemet [®] Electronics	C0805C105K8RACTU
2	C7, C8	CAP 22PF 50V CERM CHIP 0805 SMD	Panasonic [®] - ECG	ECJ-2VC1H220J
1	C9	CAP CER 4700PF 100V X7R 10% 0805	TDK [®] Corporation	C2012X7R2A472K
6	C10, C11, C18, C21, C26, C27	CAP .1UF 25V CERAMIC X7R 0805	Panasonic - ECG	ECJ-2VB1E104K
1	C13	10uF/16V CAP-SMT-ELCTRO	Value-Pro	SE10/16
1	D1	DIODE ZENER 4.3V 150MW S-MINI 2P	Panasonic - SSG	MAZ80430ML
1	D2	MA3X786E0LCT-ND	Panasonic - SSG	MA3X786E0L
0	J1	Do Not Populated Header	—	—
1	J2	CONN RECEPT MINI USB2.0 5POS	Hirose Electronic Co Ltd	UX60-MB-5ST
1	J2	USB A Male to Mini USB B 5 pin Cable - 3ft phone:(316)522-2002	http://www.store.yahoo.com/ktusasys/usbtomib5pin.html	sales@ktusasys.com
1	J4	CONN TERM BLOCK 4POS 5MM PCB	Phoenix Contact	1729034
2	JMP1, JMP2	3PIN, .100" Straight Male Headers (Gold)	Value-Pro	7000-1X3SG-R
1	PCB	RoHS Compliant Bare PCB, PT100 RTD Evaluation Board	—	104-00096
2	Q1, Q2	IC AMP GP PNP 60V 0.8A SOT23	Fairchild Semiconductor [®]	BSR16
2	R1, R2	RES 100 OHM 1/8W 1% 0805 SMD	Panasonic - ECG	ERJ-6ENF1000V
1	R3	RES 20.0 OHM 1/8W 1% 0805 SMD	Panasonic - ECG	ERJ-6ENF20R0V
1	R4	RES 100 OHM 1/10W 0.1% 0805 SMD	Susumu Co Ltd	RR1220P-101-B-T5
2	R5, R6	ES 7.15K OHM 1/8W 1% 0805 SMD	Panasonic - ECG	ERJ-6ENF7151V
7	R7, R8, R12, R14, R16, R17, R24	RES 4.99K OHM 1/8W 1% 0805 SMD	Panasonic - ECG	ERJ-6ENF4991V
2	R9, R10	RES 10.0K OHM 1/8W 1% 0805 SMD	Panasonic - ECG	ERJ-6ENF1002V
1	R11	RES 1.80M OHM 1/8W 1% 0805 SMD	Yageo [®] America	RC0805FR-071M8L
1	R13	PLATINUM RTD CHIP TEMPERATURE SENSOR SMD	ENERCORP enercorp.com	Model: PCS 1.1503.1

Note: The components listed in this Bill of Materials are representative of the PCB assembly. The released BOM used in manufacturing uses all RoHS-compliant components.

Bill Of Materials (BOM)

TABLE B-1: BILL OF MATERIALS (CONTINUED)

Qty	Reference	Description	Manufacturer	Part Number
1	R15	RES 35.7K OHM 1/8W 1% 0805 SMD	Panasonic - ECG	ERJ-6ENF3572V
3	R18, R22, R23	RES 1.00K OHM 1/10W 1% 0805 SMD	Panasonic - ECG	ERJ-6ENF1001V
2	R19, R21	RES 10.0 OHM 1/8W 1% 0805 SMD	Panasonic - ECG	ERJ-6ENF10R0V
1	R20	RES 619K OHM 1/8W 1% 0805 SMD	Panasonic - ECG	ERJ-6ENF6193V
20	TP1<->TP20	TEST POINT PC COMPACT SMT	Keystone Electronics®	5016
1	U1	Single-Ended, Rail-to-Rail I/O, Low Gain PGA	Microchip Technology Inc.	MCP6S26T-I/SL
1	U2	1 Mhz. Low Power Op-Amp	Microchip Technology Inc.	MCP6002-I/SN
1	U3	Rail-to-Rail Input/Output, 10 MHz Op Amps	Microchip Technology Inc.	MCP6024-I/SL
1	U4	28/40/44-Pin, High-Performance, Enhanced Flash, USB microcontrollers with nanoWatt Technology	Microchip Technology Inc.	PIC18F2550-I/SO
1	U5	13-Bit Differential Input, Low-Power A/D Converter with SPI Serial Interface	Microchip Technology Inc.	MCP3301-BI/SN
1	U6	50mA, 100mA and 150mA Adjustable CMOS LDOs with Shutdown	Microchip Technology Inc.	TC1071VCT
3	U8,U9,U10	Single/Dual Digital Potentiometer with SPI Interface	Microchip Technology Inc.	MCP41010-I/SN
1	Y1	CRYSTAL 20.0000 MHZ 18PF SMD	Citizen America Corp.	CS20-20.000MABJ-UT

Note: The components listed in this Bill of Materials are representative of the PCB assembly. The released BOM used in manufacturing uses all RoHS-compliant components.

Bill Of Materials (BOM)

NOTES: