



Chipsmall Limited consists of a professional team with an average of over 10 year of expertise in the distribution of electronic components. Based in Hongkong, we have already established firm and mutual-benefit business relationships with customers from,Europe,America and south Asia,supplying obsolete and hard-to-find components to meet their specific needs.

With the principle of “Quality Parts,Customers Priority,Honest Operation,and Considerate Service”,our business mainly focus on the distribution of electronic components. Line cards we deal with include Microchip,ALPS,ROHM,Xilinx,Pulse,ON,Everlight and Freescale. Main products comprise IC,Modules,Potentiometer,IC Socket,Relay,Connector.Our parts cover such applications as commercial,industrial, and automotives areas.

We are looking forward to setting up business relationship with you and hope to provide you with the best service and solution. Let us make a better world for our industry!



Contact us

Tel: +86-755-8981 8866 Fax: +86-755-8427 6832

Email & Skype: info@chipsmall.com Web: www.chipsmall.com

Address: A1208, Overseas Decoration Building, #122 Zhenhua RD., Futian, Shenzhen, China



AEC-Q101 Qualified 650V Cascode GaN FET in TO-247 (source tab)

Description

The TPH3205WSBQA 650V, 49mΩ gallium nitride (GaN) FET is a normally-off device. Transphorm GaN FETs offer better efficiency through lower gate charge, faster switching speeds, and smaller reverse recovery charge, delivering significant advantages over traditional silicon (Si) devices.

Transphorm is a leading-edge wide band gap supplier with world-class innovation and a portfolio of fully-qualified GaN transistors that enables increased performance and reduced overall system size and cost.

Related Literature

- [AN0009](#): Recommended External Circuitry for GaN FETs
- [AN0003](#): Printed Circuit Board Layout and Probing
- [AN0010](#): Paralleling GaN FETs

Ordering Information

Part Number	Package	Package Configuration
TPH3205WSBQA	3 Lead TO-247	Common Source

Features

- Easy to drive—compatible with standard gate drivers
- Low conduction and switching losses
- Low Qrr of 136nC—no free-wheeling diode required
- GSD pin layout improves high speed design
- JEDEC-qualified GaN technology
- RoHS compliant and Halogen-free
- AEC-Q101 qualified

Benefits

- Increased efficiency through fast switching
- Increased power density
- Reduced system size and weight
- Enables more efficient topologies—easy to implement bridgeless totem-pole designs
- Lower BOM cost

Applications

- Automotive
- Renewable energy
- Industrial
- Telecom and datacom
- Servo motors

Key Specifications	
V _{DS} (V) min	650
V _{TDS} (V) max	800
R _{DS(on)} (mΩ) max*	62
Q _{rr} (nC) typ	136
Q _g (nC) typ	28

* Dynamic R_{DS(on)}

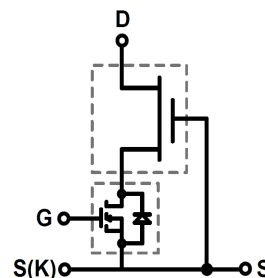
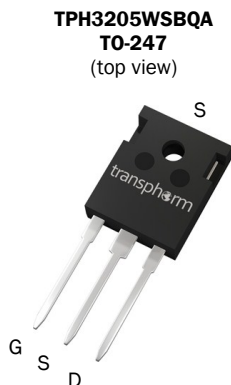

Cascode Device Structure

TPH3205WSBQA

Absolute Maximum Ratings ($T_C=25^\circ\text{C}$ unless otherwise stated)

Symbol	Parameter	Limit Value	Unit
$I_{D25^\circ\text{C}}$	Continuous drain current @ $T_C=25^\circ\text{C}$ ^a	35.2	A
$I_{D100^\circ\text{C}}$	Continuous drain current @ $T_C=100^\circ\text{C}$ ^a	22.3	A
I_{DM}	Pulsed drain current (pulse width: 10 μs)	150	A
V_{DSS}	Drain to source voltage	650	V
V_{TDS}	Transient drain to source voltage ^b	800	V
V_{GSS}	Gate to source voltage	± 18	V
$P_{D25^\circ\text{C}}$	Maximum power dissipation	125	W
T_C	Operating temperature	Case	-55 to +150
T_J		Junction	-55 to +150
T_S	Storage temperature	-55 to +150	$^\circ\text{C}$
T_{CSOLD}	Soldering peak temperature ^c	260	$^\circ\text{C}$
-	Mounting Torque	60	N cm

Thermal Resistance

Symbol	Parameter	Typical	Unit
$R_{\theta JC}$	Junction-to-case	1	$^\circ\text{C}/\text{W}$
$R_{\theta JA}$	Junction-to-ambient	40	$^\circ\text{C}/\text{W}$

Notes:

- For high current operation, see application note AN0009
- In off-state, spike duty cycle $D < 0.01$, spike duration $< 1\mu\text{s}$
- For 10 sec., 1.6mm from the case

TPH3205WSBQA

Electrical Parameters (T_C=25 °C unless otherwise stated)

Symbol	Parameter	Min	Typ	Max	Unit	Test Conditions
Forward Device Characteristics						
V _{DSS-MAX}	Maximum drain-source voltage	650	—	—	V	V _{GS} =0V
V _{GS(th)}	Gate threshold voltage ^d	1.6	2.1	2.6	V	V _{DS} =V _{GS} , I _D =0.7mA
R _{DS(on)}	Drain-source on-resistance (T _J =25 °C) ^a	—	49	62	mΩ	V _{GS} =8V, I _D =22A, T _J =25 °C
	Drain-source on-resistance (T _J =150 °C) ^a	—	105	—		V _{GS} =8V, I _D =22A, T _J =150 °C
I _{DSS}	Drain-to-source leakage current (T _J =25 °C)	—	4	40	μA	V _{DS} =650V, V _{GS} =0V, T _J =25 °C
	Drain-to-source leakage current (T _J =150 °C)	—	50	—		V _{DS} =650V, V _{GS} =0V, T _J =150 °C
I _{GSS}	Gate-to-source forward leakage current	—	—	100	nA	V _{GS} =18V
	Gate-to-source reverse leakage current	—	—	-100		V _{GS} =-18V
C _{ISS}	Input capacitance	—	2200	—	pF	V _{GS} =0V, V _{DS} =400V, f=1MHz
C _{OSS}	Output capacitance	—	135	—		
C _{RSS}	Reverse transfer capacitance	—	23	—		
C _{O(er)}	Output capacitance, energy related ^b	—	190	—	pF	V _{GS} =0V, V _{DS} =0V to 400V
C _{O(tr)}	Output capacitance, time related ^c	—	300	—		
Q _g	Total gate charge	—	28	42	nC	V _{DS} =400V, V _{GS} =0V to 8V, I _D =22A
Q _{gs}	Gate-source charge	—	10	—		
Q _{gd}	Gate-drain charge	—	6	—		
t _{d(on)}	Turn-on delay	—	36	—	ns	V _{DS} =400V, V _{GS} =0V to 8V, I _D =22A, R _G =4Ω including driver output resistance (See Figure 13)
t _r	Rise time	—	7.6	—		
T _{d(off)}	Turn-off delay	—	40	—		
t _f	Fall time	—	8.6	—		
Reverse Device Characteristics						
I _S	Reverse current	—	—	22	A	V _{GS} =0V, T _C =100 °C ≤50% Duty Cycle
V _{SD}	Reverse voltage ^a	—	2.0	2.4	V	V _{GS} =0V, I _S =22A, T _J =25 °C
		—	1.5	1.7		V _{GS} =0V, I _S =11A, T _J =25 °C
t _{rr}	Reverse recovery time	—	40	—	ns	I _S =22A, V _{DD} =400V, di/dt=1000A/μs, T _J =25 °C
Q _{rr}	Reverse recovery charge	—	136	—	nC	

Notes:

- Dynamic value
- Equivalent capacitance to give same stored energy from 0V to 400V
- Equivalent capacitance to give same charging time from 0V to 400V
- Recommended gate drive: Turn on +8V, turn off 0 or -5V. For half bridge, use isolated driver ICs with 5V UVLO.

TPH3205WSBQA

Typical Characteristics (25 °C unless otherwise stated)

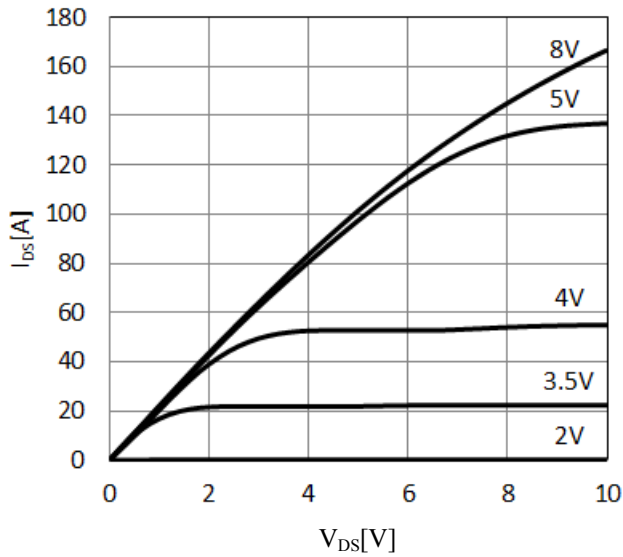

Figure 1. Typical Output Characteristics $T_J=25^\circ\text{C}$
Parameter: V_{GS}

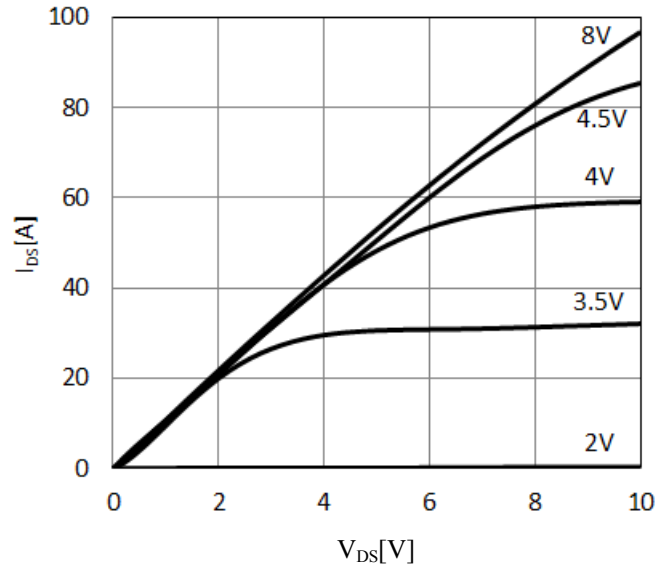

Figure 2. Typical Output Characteristics $T_J=150^\circ\text{C}$
Parameter: V_{GS}

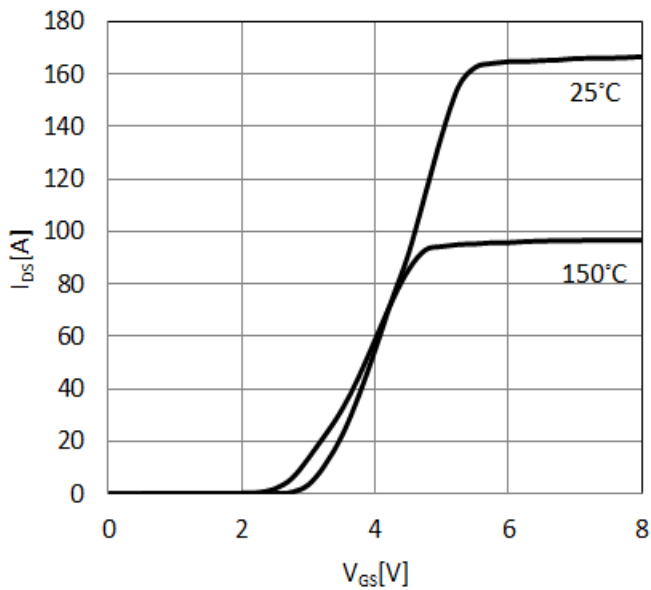

Figure 3. Typical Transfer Characteristics
 $V_{DS}=10\text{V}$, parameter: T_J

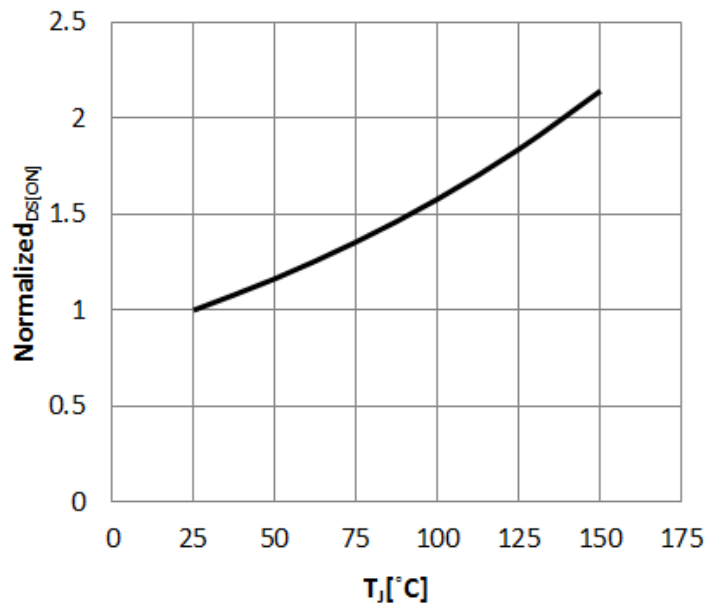

Figure 4. Normalized On-Resistance
 $I_D=22\text{A}$, $V_{GS}=8\text{V}$

TPH3205WSBQA

Typical Characteristics (25 °C unless otherwise stated)

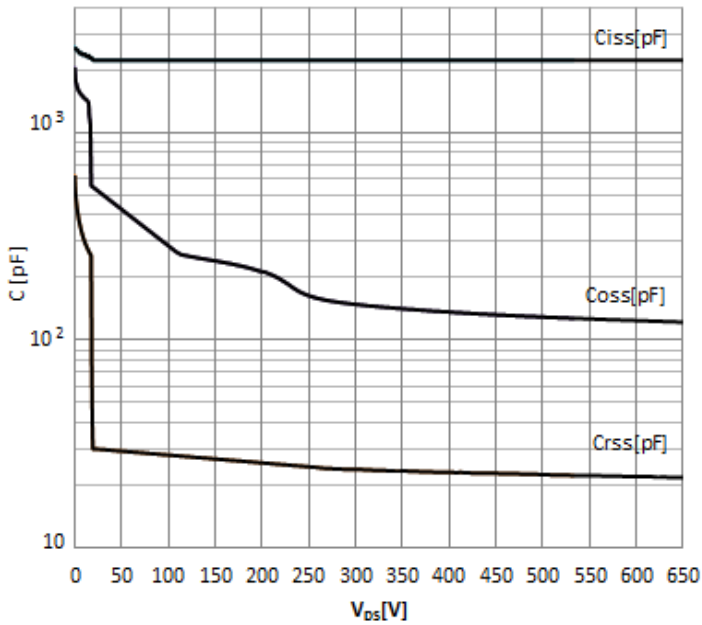

Figure 5. Typical Capacitance

$V_{GS}=0V$, $f=1MHz$

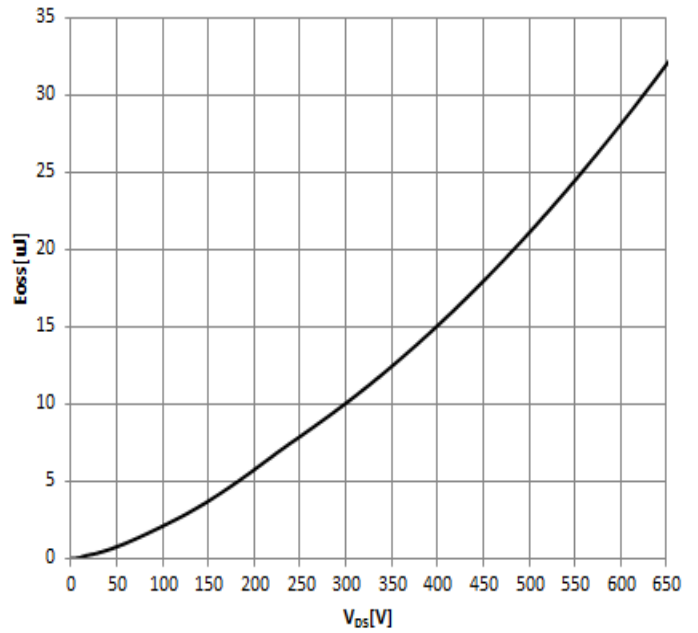

Figure 6. Typical Coss Stored Energy

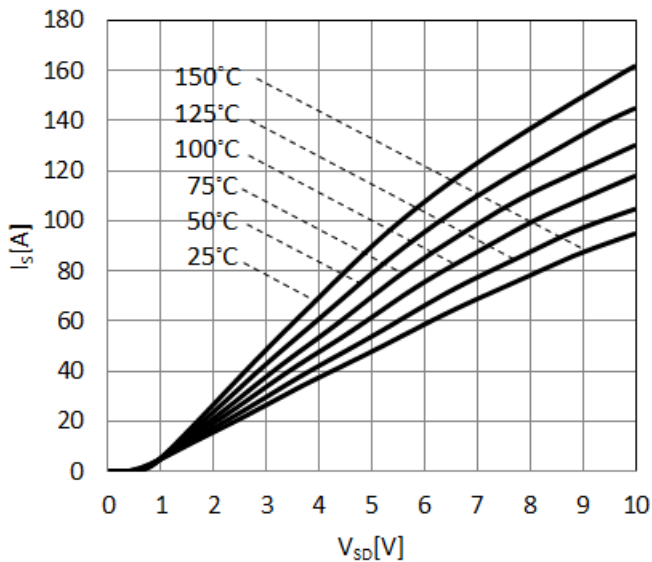

Figure 7. Forward Characteristics of Rev. Diode

$I_s=f(V_{SD})$; parameter: T_J ; pulse width = 20 μs

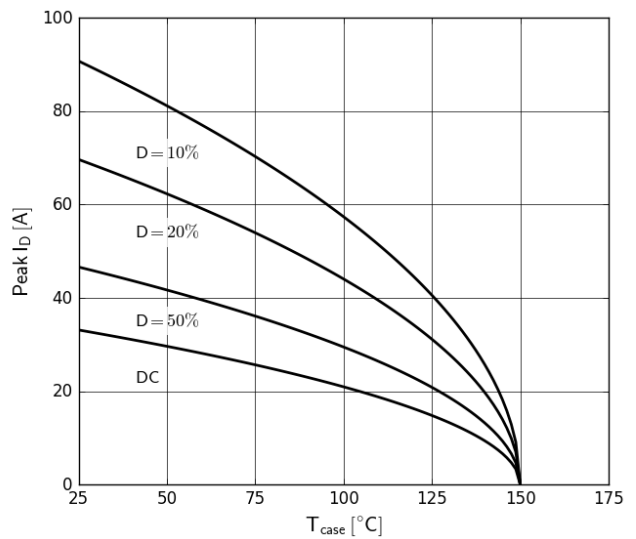
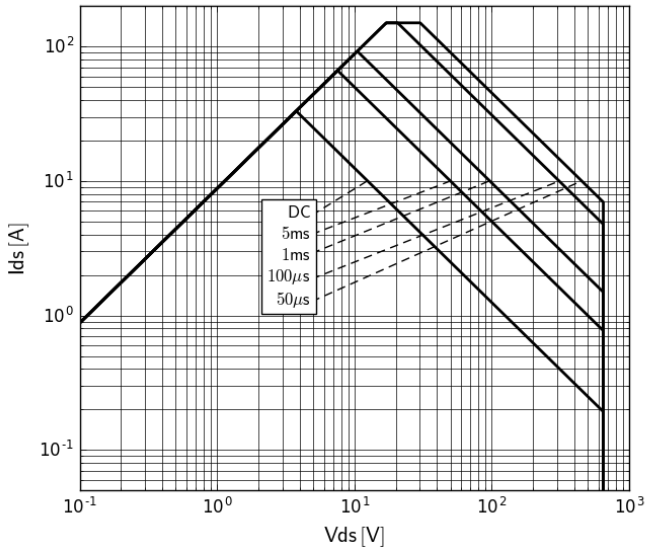

Figure 8. Current Derating

Pulse width $\leq 10\mu s$

TPH3205WSBQA

Typical Characteristics (25 °C unless otherwise stated)



**Figure 9. Safe Operating Area $T_C=25^\circ\text{C}$
(calculated based on thermal limit)**

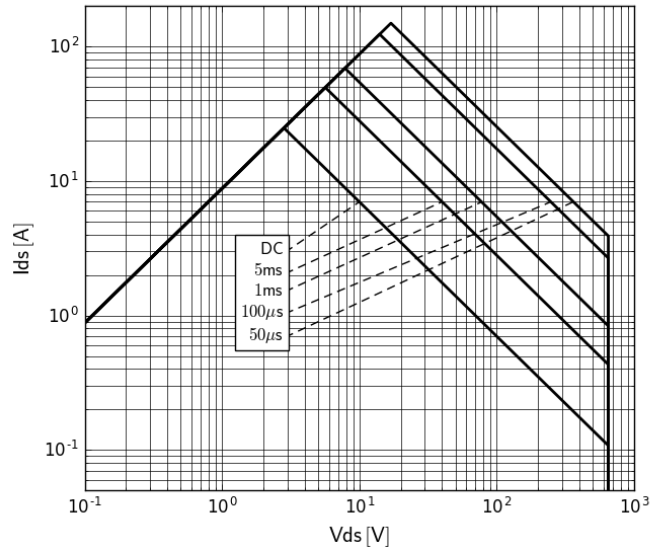

**Figure 10. Safe Operating Area $T_C=80^\circ\text{C}$
(calculated based on thermal limit)**

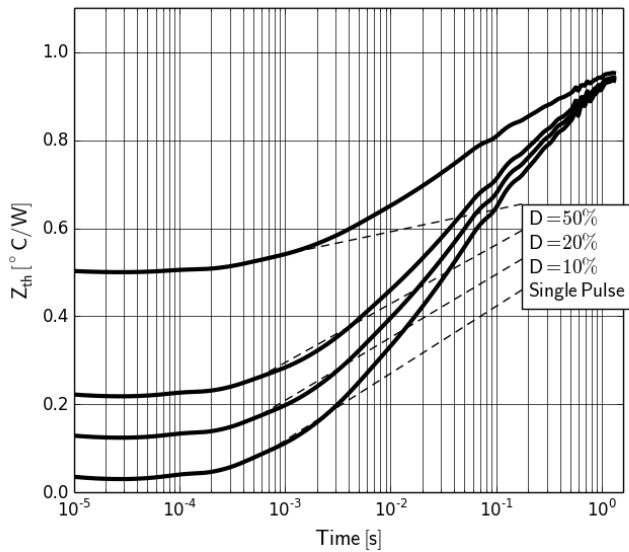

Figure 11. Transient Thermal Resistance

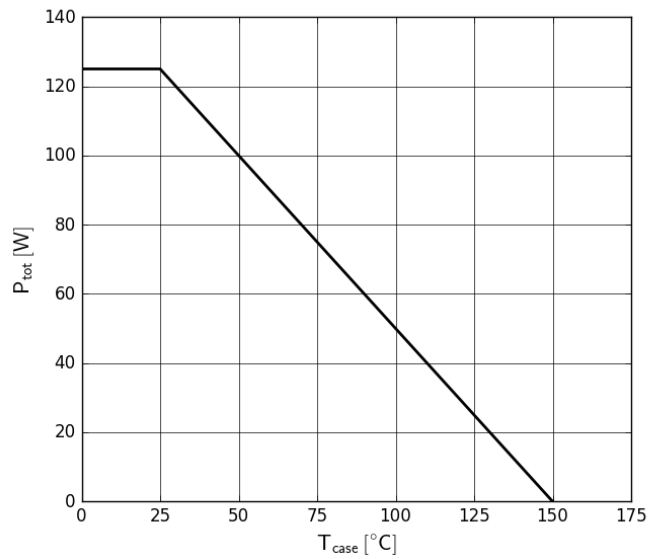

Figure 12. Power Dissipation

TPH3205WSBQA

Test Circuits and Waveforms

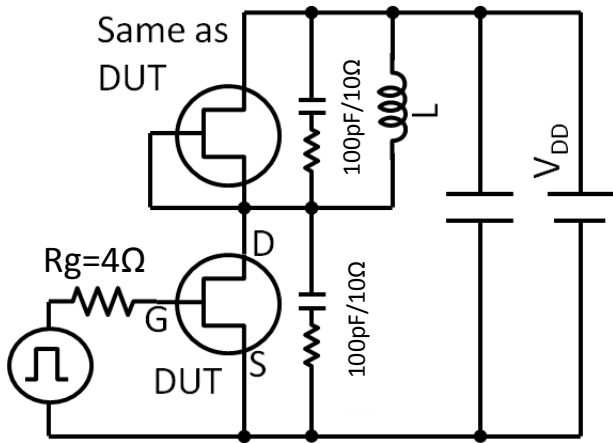

Figure 13. Switching Time Test Circuit
*See app note AN0009 for methods to ensure clean switching

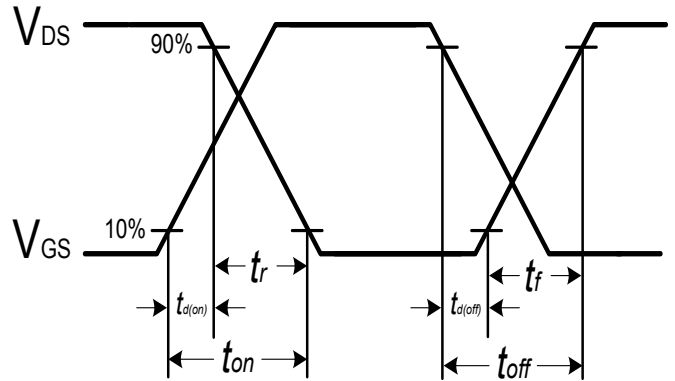

Figure 14. Switching Time Waveform

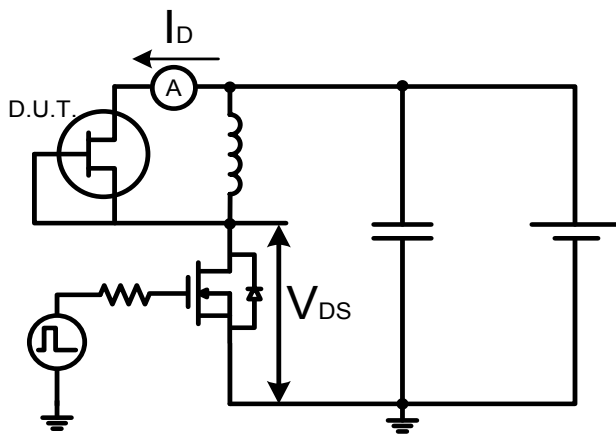

Figure 15. Test Circuit for Diode Characteristics

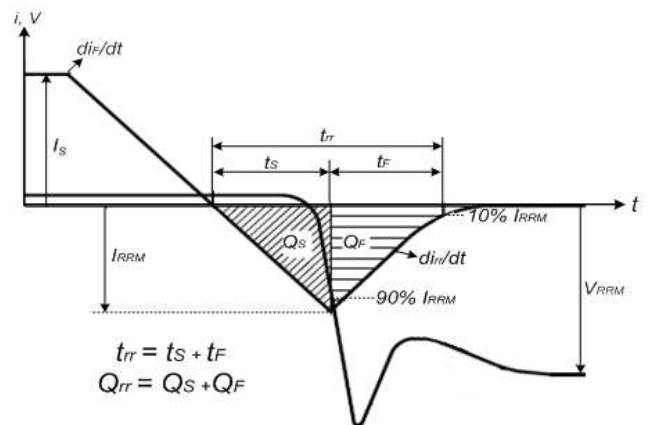

Figure 16. Diode Recovery Waveform

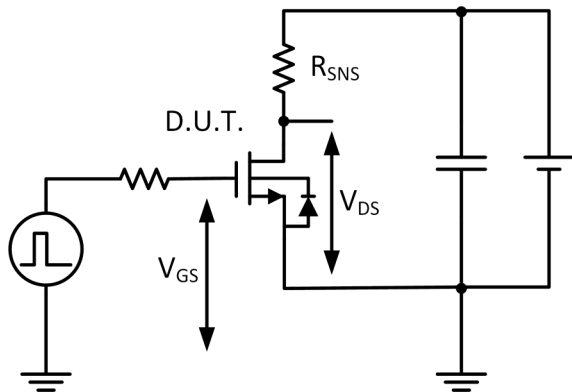

Figure 17. Test Circuit for Dynamic $R_{DS(on)}$

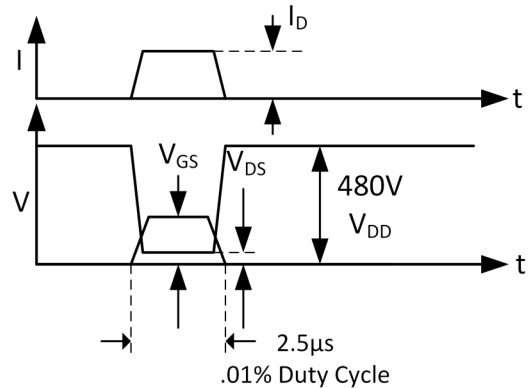
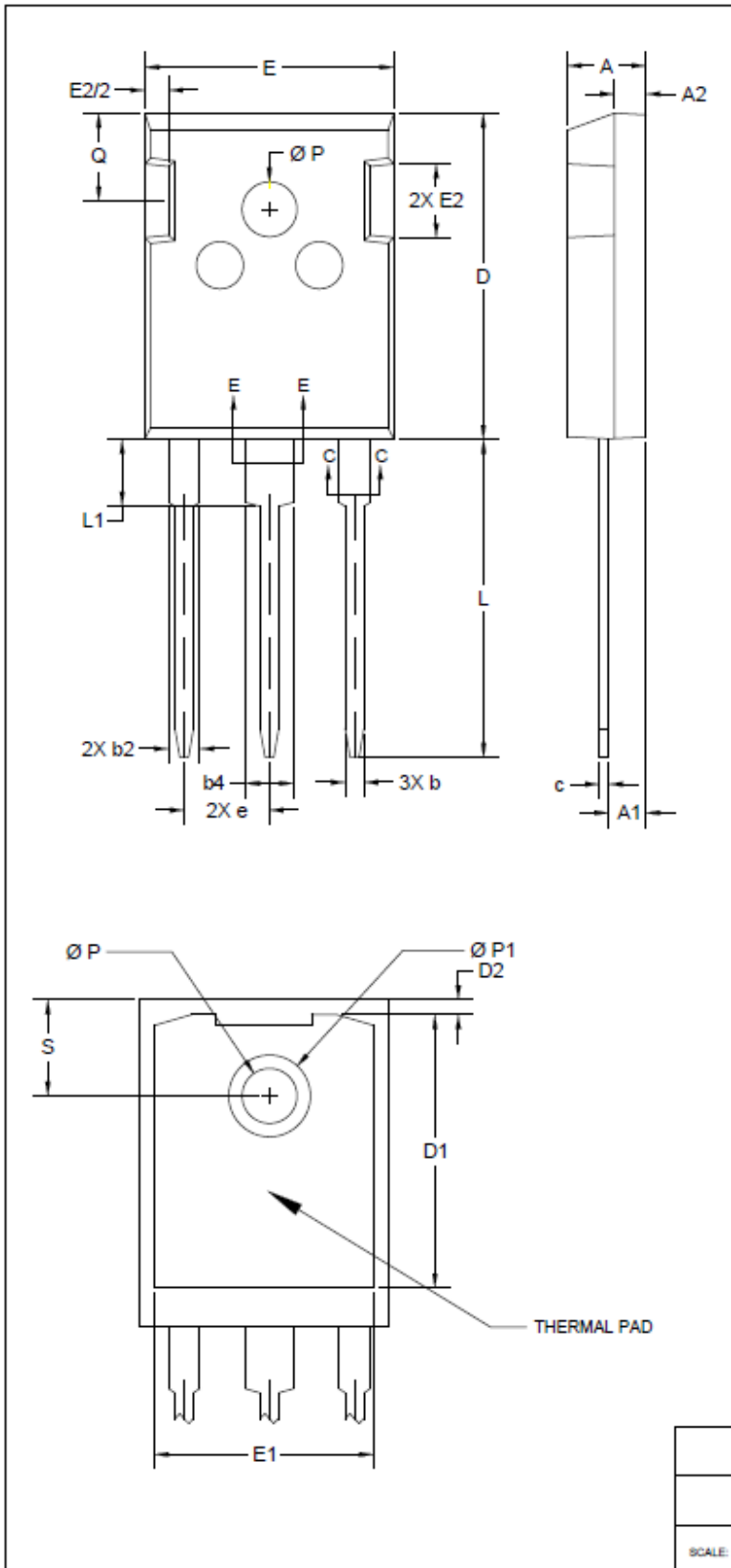

Figure 18. Dynamic $R_{DS(on)}$ Waveform

TPH3205WSBQA

Mechanical

3 Lead TO-247 Package



SYMBOL	MILLIMETERS			INCHES		
	MIN	NOM	MAX	MIN	NOM	MAX
A	4.82	5.00	5.19	0.190	0.197	0.204
A1	2.20	2.39	2.57	0.087	0.094	0.101
A2	1.82	2.01	2.18	0.072	0.079	0.086
b	1.09	1.19	1.35	0.043	0.047	0.053
b1	1.09	-	1.30	0.043	-	0.051
b2	1.87	2.03	2.31	0.074	0.080	0.091
b3	1.87	-	2.27	0.074	-	0.089
b4	2.94	3.05	3.22	0.116	0.120	0.127
b5	2.94	-	3.18	0.116	-	0.125
c	0.50	0.58	0.68	0.020	0.023	0.027
c1	0.50	-	0.64	0.020	-	0.025
D	20.67	20.85	21.11	0.814	0.821	0.831
D1	17.20	-	17.63	0.677	-	0.694
D2	0.81	-	1.20	0.032	-	0.048
E	15.72	15.90	16.15	0.619	0.626	0.636
E1	13.79	-	14.25	0.543	-	0.561
E2	4.30	-	4.86	0.169	-	0.191
e	5.46 BSC			0.215 BSC		
L	19.55	19.94	20.38	0.770	0.785	0.802
L1	3.93	4.11	4.48	0.155	0.162	0.176
ØP	3.50	3.61	3.69	0.138	0.142	0.145
ØP1	7.08	7.19	7.32	0.279	0.283	0.288
Q	5.41	-	5.85	0.213	-	0.230
s	6.15 BSC			0.242 BSC		

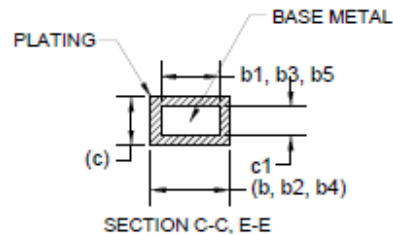

- NOTES:
1. DIMENSIONS D & E DO NOT INCLUDE MOLD FLASH. MOLD FLASH SHALL NOT EXCEED 0.127 MM (0.005") PER SIDE. THESE DIMENSIONS ARE MEASURED AT THE OUTERMOST EXTREME OF THE PLASTIC BODY.
 2. THERMAL PAD CONTOUR IS OPTIONAL WITHIN DIMENSIONS D1 & E1.
 3. LEAD FINISH UNCONTROLLED IN L1.
 4. OUTLINE CONFORMS TO JEDEC TO-247AD.

TO-247 3L			
transphorm			
SCALE: 1:1	SHEET 1/1	DRAWING NO. 200019	VER. 3

TPH3205WSBQA

Design Considerations

The fast switching of GaN devices reduces current-voltage cross-over losses and enables high frequency operation while simultaneously achieving high efficiency. However, taking full advantage of the fast switching characteristics of GaN switches requires adherence to specific PCB layout guidelines and probing techniques.

Before evaluating Transphorm GaN devices, see application note [Printed Circuit Board Layout and Probing for GaN Power Switches](#). The table below provides some practical rules that should be followed during the evaluation.

When Evaluating Transphorm GaN Devices:

DO	DO NOT
Minimize circuit inductance by keeping traces short, both in the drive and power loop	Twist the pins of TO-220 or TO-247 to accommodate GDS board layout
Minimize lead length of TO-220 and TO-247 package when mounting to the PCB	Use long traces in drive circuit, long lead length of the devices
Use shortest sense loop for probing; attach the probe and its ground connection directly to the test points	Use differential mode probe or probe ground clip with long wire
See AN0003 : Printed Circuit Board Layout and Probing	

Application Notes

- [AN0002](#): Characteristics of Transphorm GaN Power Switches
- [AN0003](#): Printed Circuit Board Layout and Probing
- [AN0004](#): Designing Hard-switched Bridges with GaN
- [AN0008](#): Drain Voltage and Avalanche Ratings for GaN FETs
- [AN0009](#): Recommended External Circuitry for GaN FETs
- [AN0010](#): GaN FETs in Parallel Using Drain Ferrite Beads and RC Snubbers for High-power Applications

Evaluation Boards

- TDPS2800E2C1-KIT: 2.8kW totem-pole PFC evaluation platform
- TDPS3500E0E10-KIT: 3.5kW hard-switched half-bridge, buck, or boost evaluation platform

TPH3205WSBQA

Revision History

Version	Date	Change(s)
0	3/1/2017	QA version denotes Q101 qualification