



Chipsmall Limited consists of a professional team with an average of over 10 year of expertise in the distribution of electronic components. Based in Hongkong, we have already established firm and mutual-benefit business relationships with customers from,Europe,America and south Asia,supplying obsolete and hard-to-find components to meet their specific needs.

With the principle of “Quality Parts,Customers Priority,Honest Operation,and Considerate Service”,our business mainly focus on the distribution of electronic components. Line cards we deal with include Microchip,ALPS,ROHM,Xilinx,Pulse,ON,Everlight and Freescale. Main products comprise IC,Modules,Potentiometer,IC Socket,Relay,Connector.Our parts cover such applications as commercial,industrial, and automotives areas.

We are looking forward to setting up business relationship with you and hope to provide you with the best service and solution. Let us make a better world for our industry!



Contact us

Tel: +86-755-8981 8866 Fax: +86-755-8427 6832

Email & Skype: info@chipsmall.com Web: www.chipsmall.com

Address: A1208, Overseas Decoration Building, #122 Zhenhua RD., Futian, Shenzhen, China





Features

Package	Reverse Mount type , Visible light cut-off resin Out Dimension : 3.2 x 1.6 x 1.1mm (L x W x H)
Product features	<ul style="list-style-type: none"> • Lead-free soldering compatible • RoHS compliant

Recommended Applications

- Car Stereo Equipment , Consumer Electrical Appliances , OA•FA,PC• Peripheral Device, Other General Applications

Outline Dimensions

TPS1191RB-2-TR

Unit : mm
 Weight : 6.6mg
 Tolerance : ±0.1

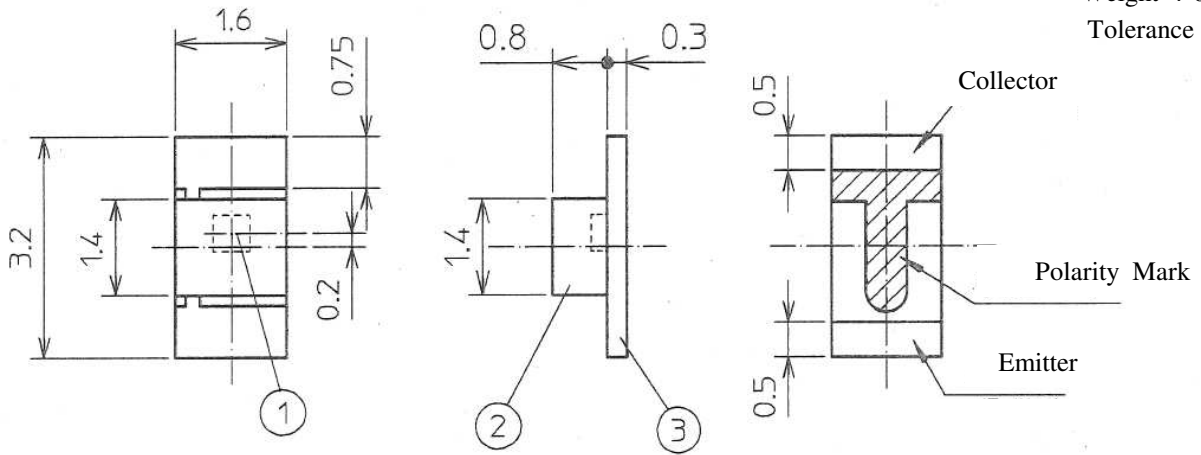

SYM.	PART NAME	MATAL.	QTY.
①	Photo Transistor	Si	1
②	Encapsulant	Epoxy Resin	1
③	Substrate	Glass Fabrics	1

Recommended Pad

Unit : mm

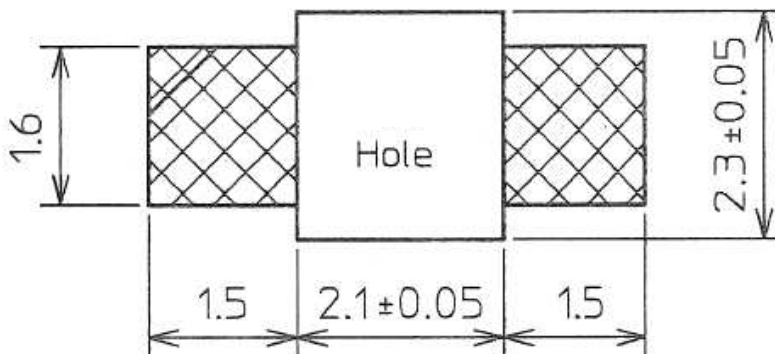

Absolute Maximum Ratings

(Ta=25°C)

Item	Symbol	Absolute Maximum Ratings	Unit
Power dissipation	Pc	75	mW
Collector-emitter voltage	V _{CEO}	30	V
Emitter-collector voltage	V _{ECO}	5	V
Collector current	I _C	20	mA
Operating temperature	T _{opr}	-30~+85	°C
Storage temperature	T _{stg}	-40~+100	°C

Electro-Optical Characteristics

(Ta=25°C)

Item	Conditions	Symbol	Characteristics		Unit	
Dark current	V _{CEO} = 10V	I _{CEO}	MAX.	0.1	μA	
Photo current	V _{CE} = 5V ☆ Ee = 5mW/cm ²	I _c	MIN.	0.7	mA	
			TYP.	1.0		
			MAX.	2.4		
Peak sensitivity wavelength	V _{CE} = 5V	λ _p	TYP.	900	nm	
Collector-emitter saturation voltage	I _c = 0.5mA, ☆ Ee = 10mW/cm ²	V _{CE(Sat)}	TYP.	0.1	V	
Response time	☆☆ V _{CE} = 10V I _c = 2mA, R _L = 100Ω		tr	TYP.	1.8	μs
			tf	TYP.	2.6	μs
Angle of sensitivity	Longitudinal direction	∠θ	TYP.	110	deg.	
	Lateral direction		TYP.	120	deg.	

☆ Tungsten filament lamp (color temperature: 2865K) is used.

☆☆ Circuit for measuring response time

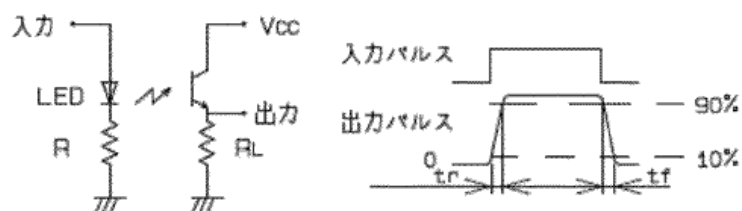

Radiant Intensity Rank

(Ta=25°C)

Ranks	Ic(mA)		Conditions
	MIN.	MAX.	
B	0.7	1.4	V _{CE} =5V E _c =5mW/cm ² T _a =25°C
C	1.2	2.4	

Radiant Intensity rank of shipped device might be any rank of above 2 ranks(B,C).

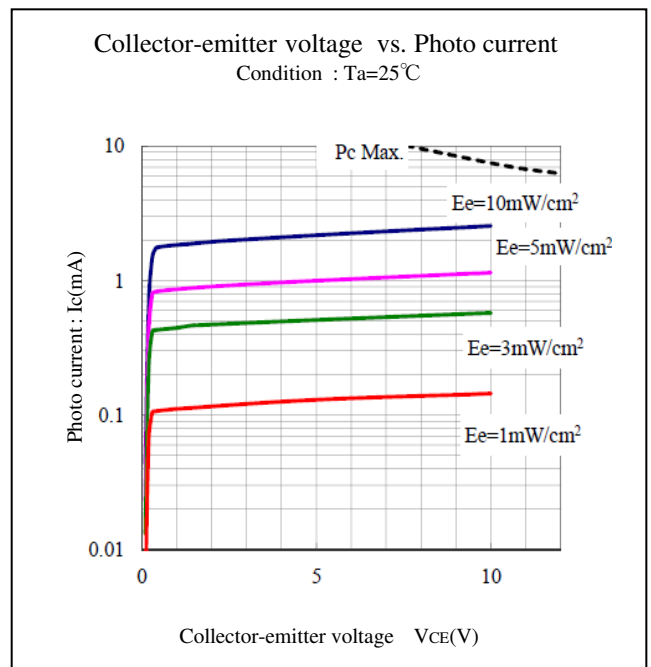
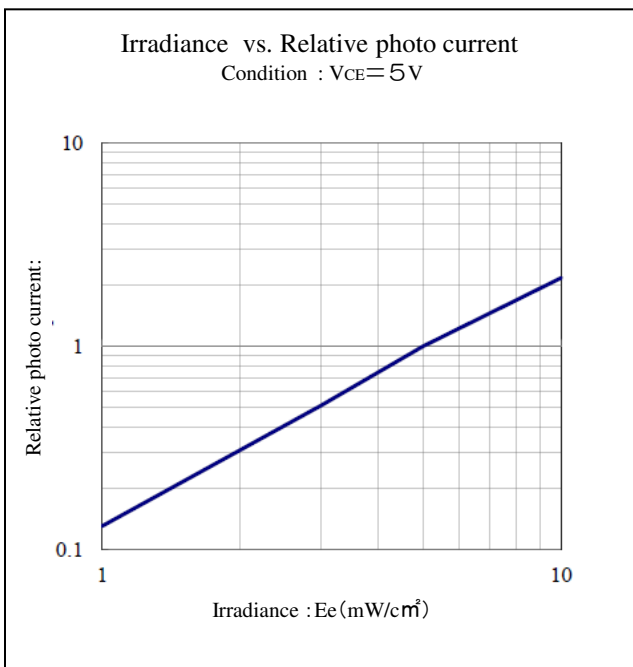
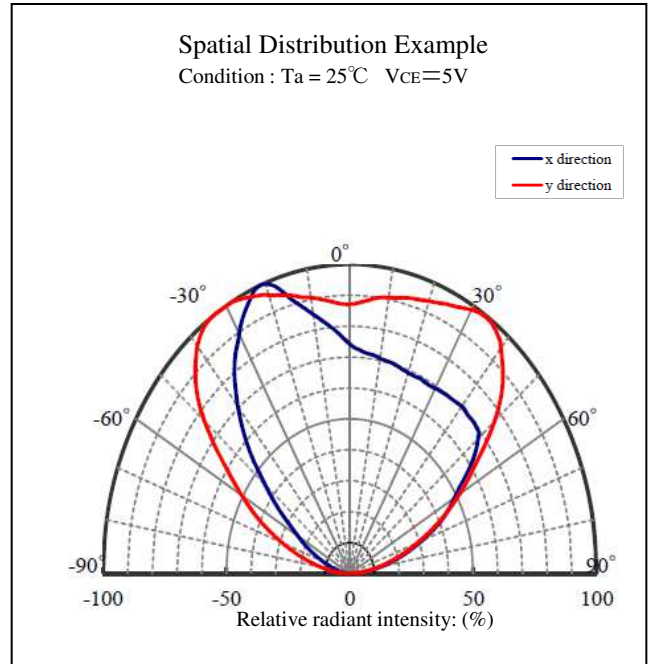
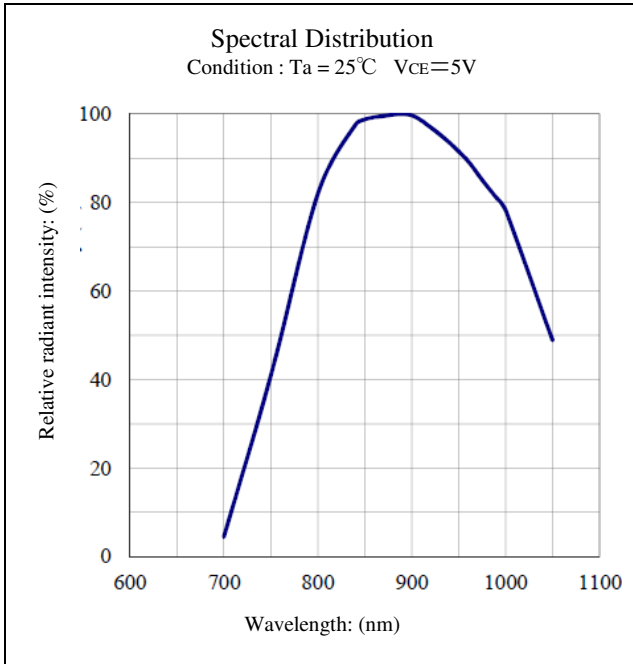

Standard: $E_e = 5 \text{ mW}/\text{cm}^2$
 Standard tungsten (2,856K) lamp used.

Standard tungsten (2,856K) lamp used.

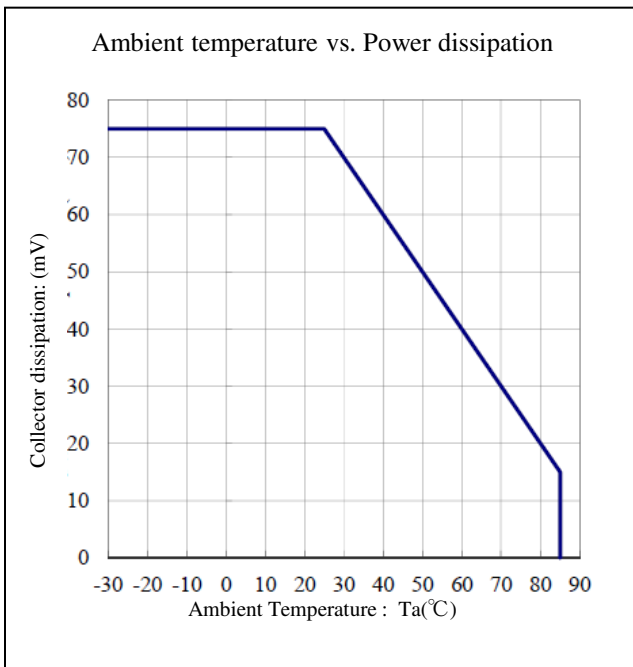
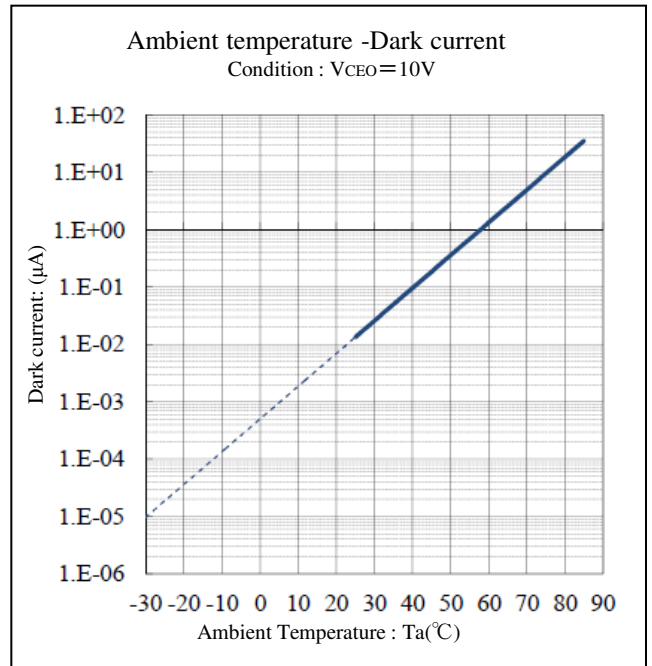
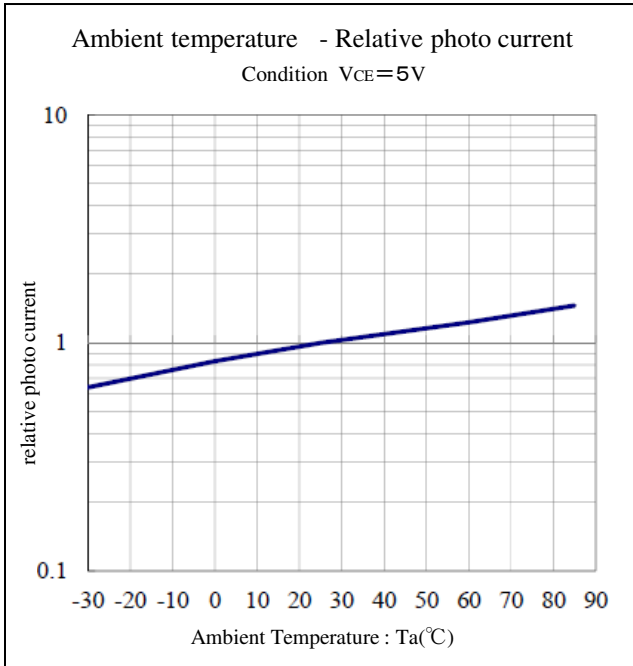

【Soldering Precaution】

1. Reflow Soldering

【Recommended Reflow Soldering Condition.】

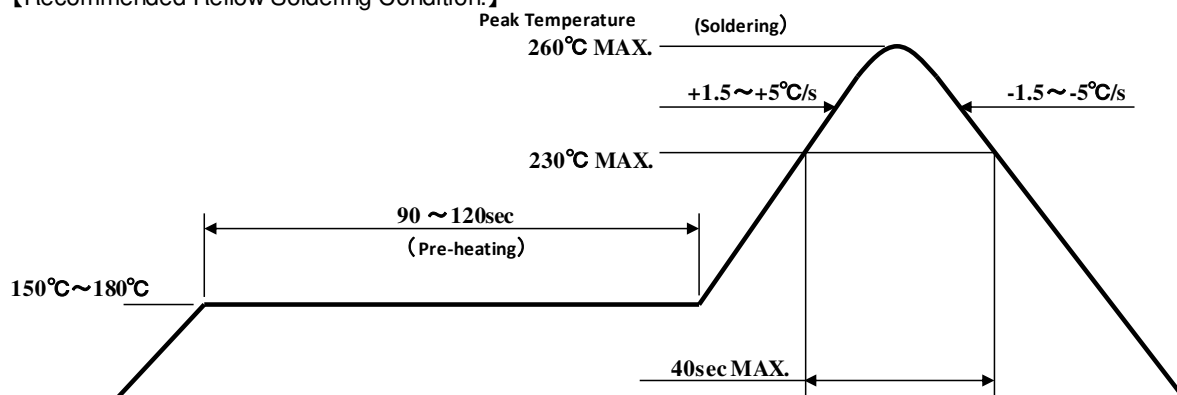

- ※ Above temperature profile for the reflow soldering is listed as the temperature of the resin surface of light receiving device.
- ※ The reflow soldering process should be done up to twice(2 times Max). When second process is performed, interval between first and second process should be as short as possible to prevent absorption of moisture to resin of device. The second soldering process should not be done until devices have returned to room temperature (by nature-cooling) after first soldering process.
- ※ Temperature fluctuation to device at pre-heat process shall be minimized. (6°C MAX.)

2. Dip soldering

Not recommended for this product.

3. Manual Soldering (Soldering iron)

Recommended Manual Soldering Condition

Temperature of Iron Tip	350°C MAX.
Soldering Duration, Time	3sec. Max., 1 time

4. Other Caution

- ① During the actual soldering process, make sure that the soldering iron never touch the device (especially the resin part).
- ② When using adhesive material for tentative fixatives, thermosetting resin or Ultraviolet radiation (UV) setting resin with heat shall be recommended.
《The curing condition, Temperature:150°C Max./Time:120sec. Max.》
- ③ Please avoid any mechanical stress or any excess vibration after soldering (when they are not at room temperature) .

- ④ When device need to repair, please choose any of the 3 methods below.
Any mechanical stress or any excess vibration should be avoided no matter which method is used.

a) Replace with new device

b) Repair immediately after soldering

To avoid moisture absorption repair should be finished within 3 hours after soldering under following conditions. Repair should be done only once.

Temperature: +5~+30°C Humidity:70% MAX.

Please note that device should be left at room temperature for natural cooling after soldering.
Rapid cooling should be avoided.

c) Repair over 3 hours after soldering

Baking should be done first before repair.

Repair should be done only once under following conditions.

Temperature:+60±5°C 23h MIN. 48h MAX.

【Solder paste】

Apply correct amount of solder paste to soldering pad to prevent device from getting out of position. (See the diagram below)Especially, please take special care not to let solder paste infiltrate into the insert hole of the light receiving device.

※The proper solder paste thickness is 200 ~ 300 μ by stencil printing method .
2~3mg for 1 place by dispense method. However, stencil printing is recommended for its precision paste amount and apply position.

Recommended mask shape (dispense method)

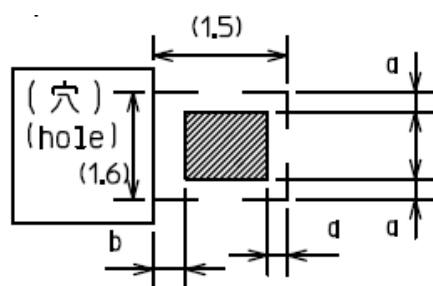

a : 0.05mm
b : 0.15mm

(Dash line: recommended soldering pad)

【Mounting】

During mounting process, make sure the pick up nozzle will not bend the device.
(Impact force under 4.9N is recommended.)

Electrical discharge prevention is recommended in a dry operating environment. Even though the tape use antistatic material , there is still possibility that product stick to the taping material depending on the electric charge amount.

Following precautions is recommended.

- 1) Environment: Electrical potential under 100V by humidity control
- 2) Peeling speed of tape: 10mm/s or less
- 3) Others: The use of static eliminator such as ion flow.

1. Cleaning

- ① Some chemicals, including Freon substitute detergent could corrode the lens or the casing surface, which cause discoloration, cloud, crack and so on. Please review the reference chart below for cleaning.

Cleaning agents	Recommended/ Not recommended
Isopropyl alcohol	✓ Recommended
Ethyl alcohol	✓ Recommended
Pure water	✓ Recommended
Trichloroethylene	x Not recommended
Chloroethene	x Not recommended
Acetone	x Not recommended
Thinner	x Not recommended

- ※ Dipping time: 3 minutes MAX. (at room temp.)
- ※ In case of pure water , please refer to section ④ below.

- ② The effect of ultrasonic cleaning on the device varies on factors such as the oscillator output, size of PCB and device mounting method. So It is strongly recommended to confirm the practical condition before cleaning.
- ③ Freon substitute detergent may cause discoloration, cloud or crack on the device surface. So prior confirmation on the practical condition is strongly recommended.
- Freon substitute detergent
 - Clean through – 750H
 - Pine alpha ST-100S
- ④ In case of water-washing, ensure to use pure water(not city water), and after the washing, immediately apply forced drying to remove the moisture completely from device.

2. Warrant period

Within 6 months under the following conditions.

- un-opened, +5 ~ +30°C / 70 % MAX.

3. Handling after opened

- ① If any device should remain unused temporary or in process, please put it back into moisture-proof packaging , reseal the package and store it under the following conditions to prevent moisture absorption.
- +5 ~ +30°C / 70 % MAX.
- ② Unpacked devices should be stored under the following conditions. Soldering must be finished within 72h whether they have been restored in moisture-proof bag or not.
- +5 ~ +30°C / 70 % MAX.
- ③ Should 72h pass after packaging being opened ,or should the desiccant (silica gel) change color (Blue→Pink), please perform baking before use under the following conditions.
- +60±5°C, 23h MIN. 48h MAX.

【Moisture-proof Packaging Specification】

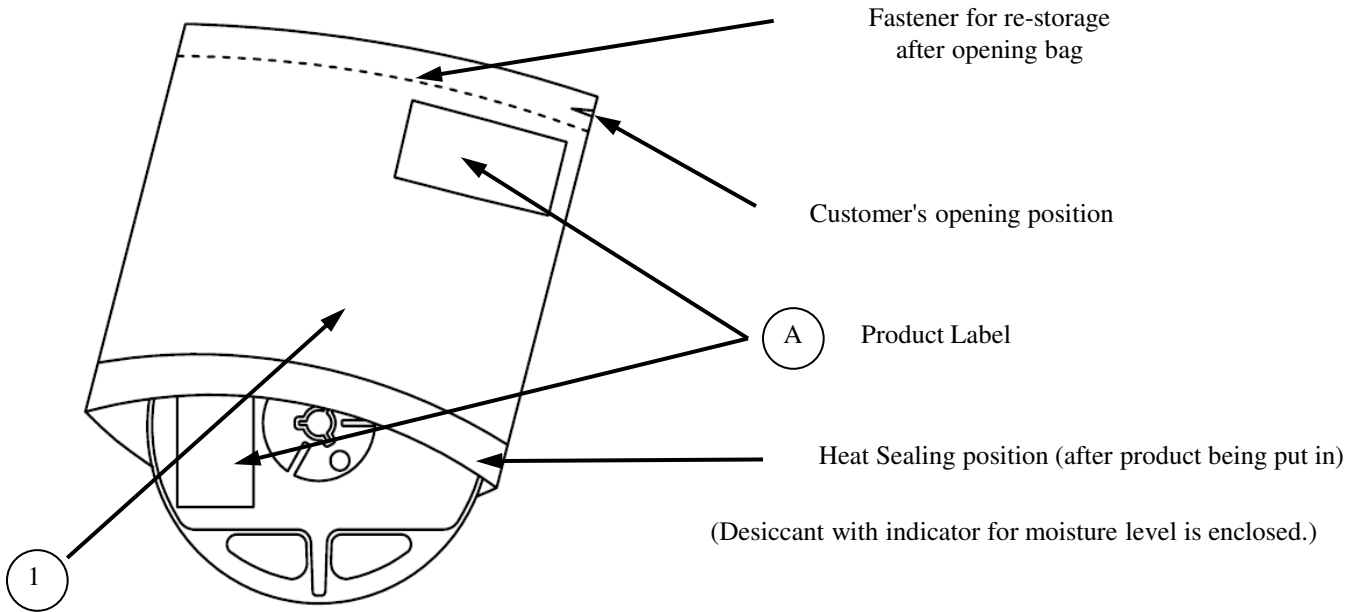

SYM.	PART NAME	MATERIAL	REMARKS
①	Moisture-proof bag with Aluminum layer	PET+Al+PE	with ESD protection

【Packing box】

(RoHS • ELV Compliant)

Box TYPE	Outline dimension L × W × H (mm)	Capacity of the box
Type A	280 × 265 × 45	3 reels
Type B	310 × 235 × 265	15 reels
Type C	440 × 310 × 265	30 reels

Note1:The above measure is all the reference value.

Note2:Shipping box is selected out of the above table by shipping quantity.

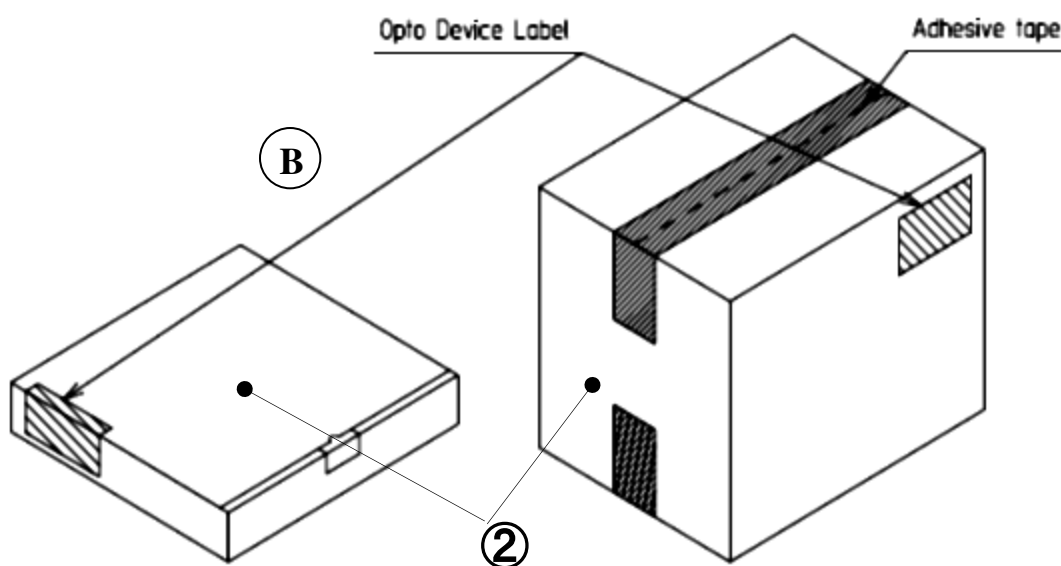

Type A

Material / box : Cardboard C5BF

Type B,C

Material / box : Cardboard K5AF
Partition : Cardboard K5BF

No.	PART NAME	MATERIAL	REMARKS
②	Packing Box	Corrugated Cardboard	without ESD protection

【Label Specification】

(acc.to JIS-X0503(Code-39))

A Product Label

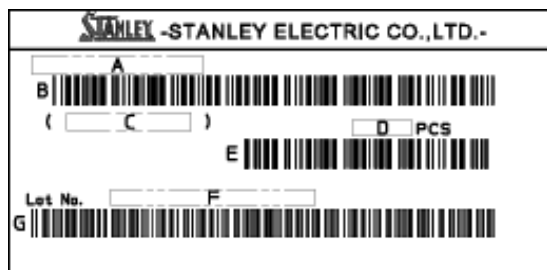

- A. Parts number
- B. Bar-code for parts number
- C. Parts code (In-house identification code for each parts number)
- D. Packed parts quantity
- E. Bar-Code for packed parts quantity
- F. Lot number & Rank (16 digits)
- G. Bar-Code for Lot number & Rank

B Opto Device Label

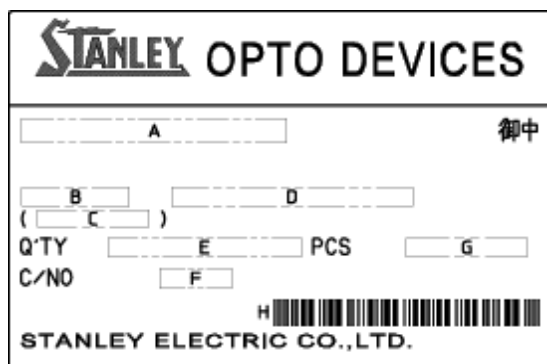

- A. Customer Name
- B. Parts Type
- C. Parts Code
- D. Parts Number
- E. Packed Parts Quantity
- F. Carton Number
- G. Shipping Date
- H. Bar-Code for In-house identification Number

<Remark> Bar-code font : acc.to Code-39(JIX0503)

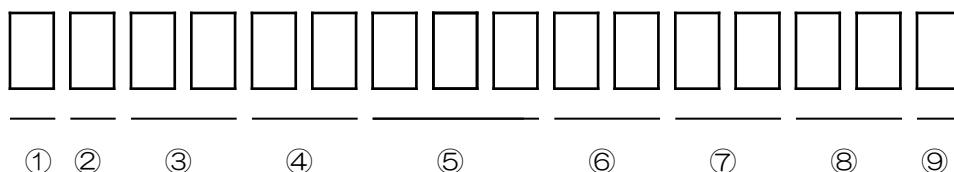

- ① - 1digit : Production Location (Mark identify alphabet)
- ② - 1digit : Production Year (Last digit of production Year 2009→9,2010→0,2011→1,···)
- ③ - 2digits : Production Month (Jan. to Sep. ,should be 01,02,03,·····)
- ④ - 2digits : Production Date
- ⑤ - 3digits : Serial Number
- ⑥ - 2digits : Tape and Reel following Number
- ⑦ - 2digits : Luminous Intensity Rank.
(If luminous intensity rank is 1 digit, "-" shall be dashed on the place for the second digit.
If there is no identified intensity rank, "- -" is used to indicate.)
- ⑧ - 2digits : Chromaticity Rank
(If chromaticity rank is 1 digit, "-" shall be dashed on the place for the second digit.
If there is no identified intensity rank, "- -" is used to indicate.)
- ⑨ - 1digit : Option Rank (Stanley normally print "-" to indicate)

(acc.to JIS-C0806-3)

【Appearance】

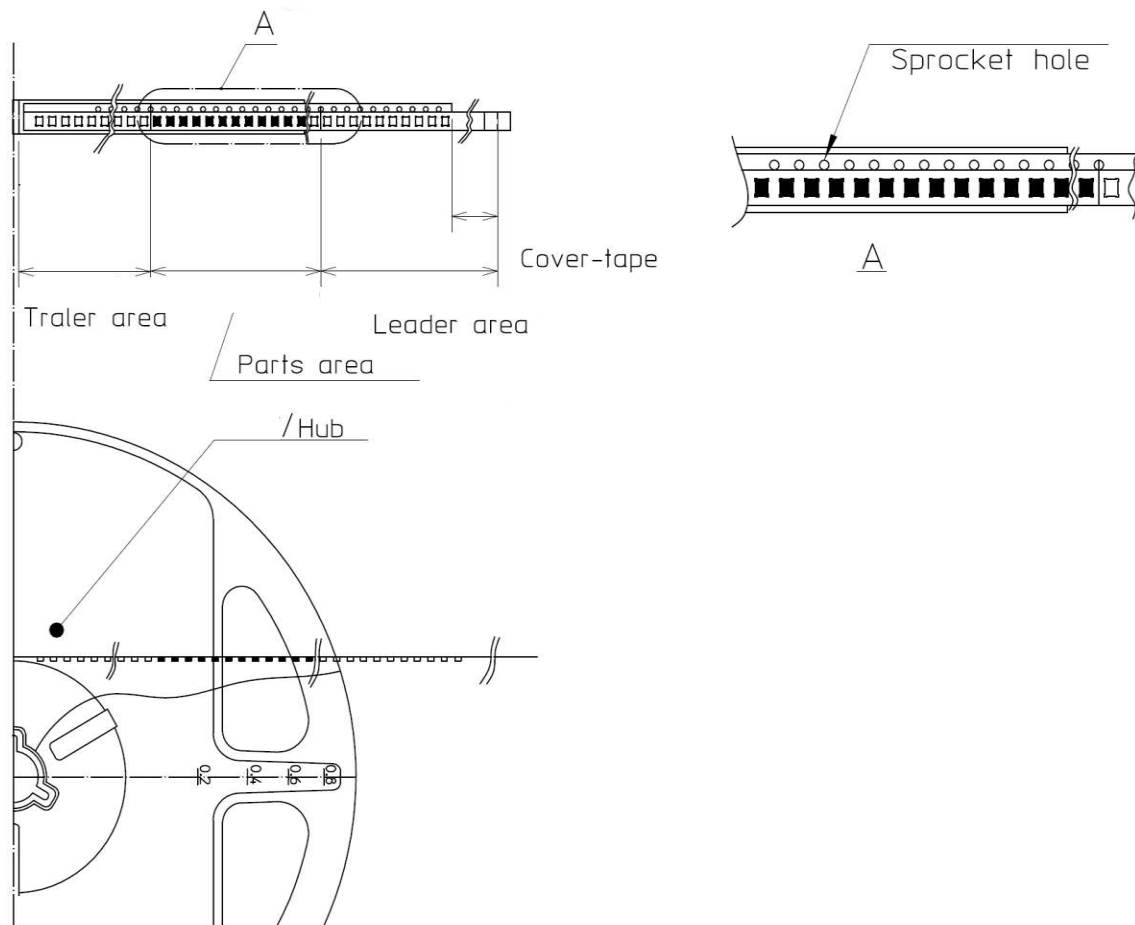

Items		Specifications	Remarks
Leader area	Cover-tape	Cover-tape shall be longer than 400mm without carrier-tape	The end of cover-tape shall be held with adhesive tape.
	Carrier-tape	Empty pocket shall be more than 25 pieces.	Please refer to the above figures for Taping & reel orientation.
Trailer area		Empty pocket shall be more than 40 pieces.	The end of taping shall be inserted into a slit of the hub.

(acc.to ; JIS-C0806-03)

【Qty. per Reel】

3,000parts/reel

【Mechanical strength】

Cover-tape adhesive strength shall be 0.1~1.0N (The angle between carrier-tape and cover-tape shall be 165 ~ 180 deg.) Both tapes shall be so sealed that the contained parts will not come out from the tape when it is bent at a radius of 15mm.

【 Packaging box】

Name of Stanley Electric Co., Ltd., parts number and quantity shall be stated on the surface of box or bag.

Note:

Reversed-orientation, Up-side down placing, side placing and out of spec. parts mix shall not be held.

(acc.to ; JIS-C0806-03)

【Orientation of device on tape】

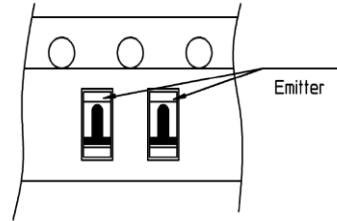

【Taping Dimensions】

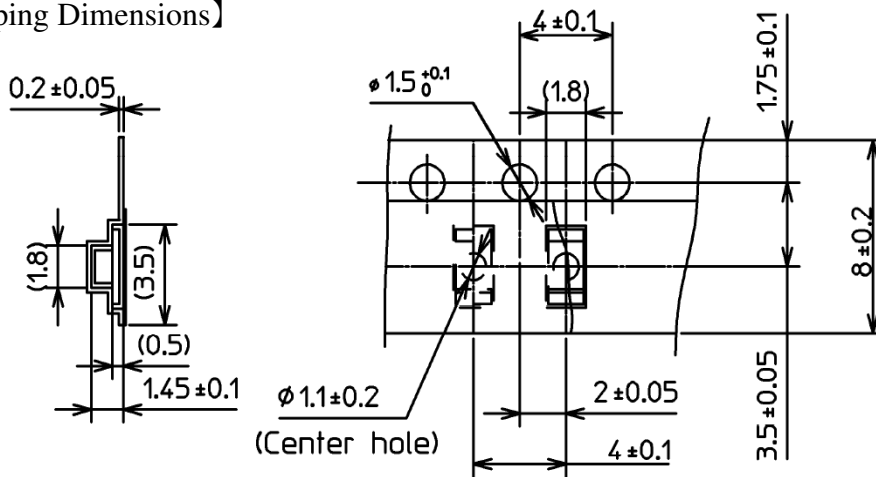

【Reel Dimensions】

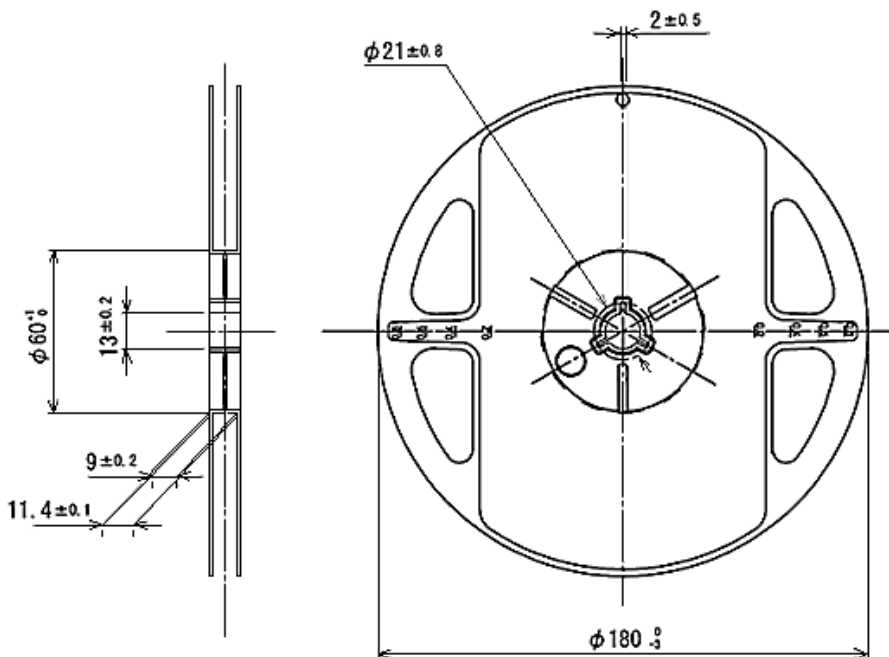

This product is in compliance with RoHS • ELV.

Prohibition substance and it's criteria value of RoHS • ELV are as follows.

- ELV instruction Refer to following (1)~(4).
- RoHS instruction Refer to following (1)~(6).

	Substance Group Name	Criteria Value
(1)	Lead and its compounds	1,000ppm Max
(2)	Cadmium and its compounds	100ppm Max
(3)	Mercury and its compounds	1,000ppm Max
(4)	Hexavalent chromium	1,000ppm Max
(5)	PBB	1,000ppm Max
(6)	PBDE	1,000ppm Max

1. Reliability Testing Result

Test Item	Standard	Test Condition	Duration	Failure
Endurance Operating Test	EIAJ ED-4701/100(101)	Ta=25°C P _C =75mW	1,000h	0/15
Humidity Resistance Operating Test	EIAJ ED-4701/100(102)	Ta=60°C RH=90% V _{CE} =5V	1,000h	0/15
High Temperature Operating Test	EIAJ ED-4701/100(105)	Ta=85°C V _{CE} =5V	1,000h	0/15
Low Temperature Operating Test	EIAJ ED-4701/100(103)	Ta=-30°C V _{CE} =5V	1,000h	0/15
Heat Cycle Test	EIAJ ED-4701/200(201)	Storage Temperature min.value (30min) ~ Ta=Storage Temperature max.value (30min)	5cycles	0/15
High Temperature Shelf Test	EIAJ ED-4701/200(202)	Ta=Storage Temperature max.value	1,000h	0/15
Low Temperature Shelf Test	EIAJ ED-4701/400(403)	Ta=Storage Temperature min.value	1,000h	0/15
Reflow Resistance Test	EIAJ ED-4701/300(301)	Preheating : 150~180°C 120sec MAX. / Soldering : 230°C,40Sec MAX. Peak 260°C MAX	2 times	0/15

Conditions:

Each Reliability Test shall be implemented after baking (24Hr at 60°C) and reflow process (2 times).

Reflow process shall be done after moisture absorption for 72h at 30°C,70%

2. Failure Criteria

Items	Symbols	Conditions	Failure criteria
Photo Current	I _C	E _E Value of each product Irradiance of Photo Current V _{CE} Value of each product Collector-emitter Voltage of Photo Current	Testing Max. Value ≥ Initial Value x 1.2 Testing Min. Value < Initial Value x 0.8
Dark Current	I _{CEO}	V _{CEO} Value of each product Collector-emitter Voltage of Dark Current	Testing Max. Value ≥ Spec. Max. Value x 2.5
External Appearance	-	-	Occurrence of notable decoloration, deformation and cracking

Special Notice to Customers Using the Products and Technical Information Shown in This Data Sheet

- 1) The technical information shown in the data sheets are limited to the typical characteristics and circuit examples of the referenced products. It does not constitute the warranting of industrial property nor the granting of any license.
- 2) For the purpose of product improvement, the specifications, characteristics and technical data described in the data sheets are subject to change without prior notice. Therefore it is recommended that the most updated specifications be used in your design.
- 3) When using the products described in the data sheets, please adhere to the maximum ratings for operating voltage, heat dissipation characteristics, and other precautions for use. We are not responsible for any damage which may occur if these specifications are exceeded.
- 4) The products that have been described to this catalog are manufactured so that they will be used for the electrical instrument of the benchmark (OA equipment, telecommunications equipment, AV machine, home appliance and measuring instrument).
The application of aircrafts, space borne application, transportation equipment, medical equipment and nuclear power control equipment, etc. needs a high reliability and safety, and the breakdown and the wrong operation might influence the life or the human body. Please consult us beforehand if you plan to use our product for the usages of aircrafts, space borne application, transportation equipment, medical equipment and nuclear power control equipment, etc. except OA equipment, telecommunications equipment, AV machine, home appliance and measuring instrument.
- 5) In order to export the products or technologies described in this data sheet which are under the "Foreign Exchange and Foreign Trade Control Law," it is necessary to first obtain an export permit from the Japanese government.
- 6) No part of this data sheet may be reprinted or reproduced without prior written permission from Stanley Electric Co., Ltd.
- 7) The most updated edition of this data sheet can be obtained from the address below:
<http://www.stanley-components.com>