



Chipsmall Limited consists of a professional team with an average of over 10 year of expertise in the distribution of electronic components. Based in Hongkong, we have already established firm and mutual-benefit business relationships with customers from,Europe,America and south Asia,supplying obsolete and hard-to-find components to meet their specific needs.

With the principle of “Quality Parts,Customers Priority,Honest Operation,and Considerate Service”,our business mainly focus on the distribution of electronic components. Line cards we deal with include Microchip,ALPS,ROHM,Xilinx,Pulse,ON,Everlight and Freescale. Main products comprise IC,Modules,Potentiometer,IC Socket,Relay,Connector.Our parts cover such applications as commercial,industrial, and automotives areas.

We are looking forward to setting up business relationship with you and hope to provide you with the best service and solution. Let us make a better world for our industry!



Contact us

Tel: +86-755-8981 8866 Fax: +86-755-8427 6832

Email & Skype: info@chipsmall.com Web: www.chipsmall.com

Address: A1208, Overseas Decoration Building, #122 Zhenhua RD., Futian, Shenzhen, China





**HIGH-PERFORMANCE
SC-PA
PRE-CERTIFIED
RF TRANSCEIVER**



SC-PA SERIES TRANSCEIVER MODULE DESIGN GUIDE

DESCRIPTION:

The PA version of Linx popular SC Series greatly reduces the time and expense of making a product wireless. This is because the transceiver module is pre-approved by the FCC when used with the appropriate proprietary antennas. The TR-XXX-SC-PA transceiver module is designed for the cost-effective, bi-directional transfer of wireless information. The Transceiver utilizes an advanced synthesized superhet architecture and has direct interface for analog or digital information, UART-compatible data output, RSSI, low power consumption, wide operational voltage, on-board TX/RX switch, SAW front-end filter, and many other useful features. Fast turnaround times, along with the support for data rates to 33.6Kbps, make the transceiver suitable for a wide range of applications. Housed in a compact through-hole package, the transceiver requires no tuning or external RF components (except antenna), allowing for straightforward application, even by engineers lacking previous RF experience.

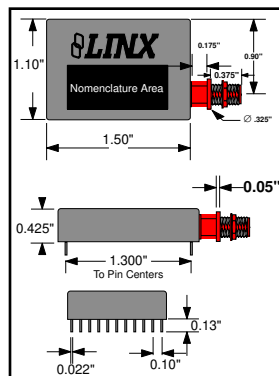

Physical Dimensions

FEATURES

- FCC precertified for immediate integration
- Direct interface for analog or digital information
- Precision crystal-controlled synthesized architecture
- Transparent serial input
- UART-compatible data output
- Built-in data squelching
- High data-rate: up to 33,600bps
- Wide-range analog capability including audio
- Single-antenna-ready (No TX/RX switch required)
- Differential LO dramatically reduces unintended radiation
- Output power can be programmed with an external resistor
- Good sensitivity (-94dBm typical at 10⁻⁵ BER)
- SAW filter on front end for superior out-of-band rejection
- Received signal strength indication
- Fast start-up and turnaround time
- Wide input voltage range (2.7 to 13 VDC)
- Very low power consumption (as low as 12 mA)
- Power-down mode – 50µA max (V_{CC} @ 5V)

APPLICATIONS

- Small Area Networks
- Wireless RS:232/485 Modems
- 2-Way Paging
- Remote Control W/ Confirmation
- Telemetry
- Data Collection
- Home/Industrial Automation
- Long-Range RFID
- Robotics
- Wire Elimination

ORDERING INFORMATION

PART #	DESCRIPTION
TR-XXX-SC-PA	SC-PA Transceiver
XXX=916MHz	

PERFORMANCE DATA TR-XXX-SC-PA

* ABOUT THESE MEASUREMENTS

The performance parameters listed below are based on module operation at 25°C from a 5VDC supply unless otherwise noted.

TRANSMIT SECTION						
Parameter	Designation	Min	Typ	Max	Units	Notes
Center Frequency	Fc		SEE TABLE 1		MHz	
Fc Tolerance		-50		+50	KHz	1
Output Power	Po	- 12	-10	- 6	dBm	2,3
Output-Power Control Range			5		dB	2,4,8
Harmonic Emissions	Ph		-45		dBm	
Spurious Emissions	compatible with FCC part 15					
Frequency Deviation		90	110	130	KHz	5
Data Rate		300		33,600	Bps	8
Audio Modulation Bandwidth		.15		17	KHz	7,8
Modulation Voltage						
Digital (Mark)		3	5	5.2	VDC	9
Digital (Space)		0	0		VDC	
Analog		0		3	Vp-p	10
RECEIVE SECTION						
LO Frequency	Flo		SEE TABLE 1		MHz	
Flo Tolerance		-50		+50	KHz	
Local Oscillator Feedthru			-65	-50	dBm	2
Spurious Emissions	compatible with FCC part 15					
Receive Sensitivity		-90	-94	-100	dBm	6
Data Rate		300		33,600	Bps	8
Required Transition Interval				3.5	ms	8,14
Audio Bandwidth		.15		17	KHz	7,8
Audio Level			180		mVp-p	8
RSSI DC Output Range			.7 to 2.5		V	8
RSSI Gain	Grssi		27		mV/dB	8
RSSI Dynamic Range			65		dB	8
ANTENNA PORT						
Designed for match			50		ohms	8
TIMING						
Power-on to Valid Receive			6	8	ms	8, 9,11
Power-on to Valid Transmit			3	5	ms	8, 9,11
RX to Valid TX Switching			3	5	ms	8,9,12
TX to Valid RX Switching			4	6	ms	8,9,13
POWER SUPPLY						
Operating Voltage	VCC (pin 10)	2.7		13	VDC	
Current Consumption	Icc					
TX Mode		12	15	19	mA	
RX Mode		10	13	15	mA	
Sleep Mode			50		uA	8
ENVIRONMENTAL						
Operational Temp.		0		70	°C	

*Table applies to S/N >1000

NOTES:

- 1) Center frequency measured while modulated with a 0-5V square wave.
- 2) Into a 50-ohm load.
- 3) LVLADJ open.
- 4) Maximum power when LVLADJ open, minimum power when LVLADJ grounded.
- 5) TXDATA pin modulated with a 0-5V square wave.
- 6) For 10^{-5} BER at 9,600 baud.
- 7) The audio bandwidth is wide to accommodate the needs of the data slicer. In audio applications, audio quality may be improved by using a low pass filter rolling off at the maximum frequency of interest.
- 8) These parameters are only characterized and not tested.
- 9) The SC-PA is optimized for 0-5V modulation when sending digital data. 0-3V modulation is possible but will slightly reduce system sensitivity and increase settling times.
- 10) Analog signals including audio should be AC-coupled. Signals in excess of 3V will cause distortion.
- 11) Time to transmitter or receiver readiness from the application of power to VIN or PDN going high.
- 12) Time from the TXEN going high and RXEN going low to the transmitter being ready to transmit data.
- 13) Time from the RXEN going high and TXEN going low to valid receiver data output.
- 14) Maximum time without a data transition.

MODEL	Center Frequency		UNITS
	TX	RX LO	
TR-916-SC-PA	916.48	905.78	MHz

Table 1



CAUTION

This product incorporates numerous static-sensitive components. Always wear an ESD wrist strap and observe proper ESD handling procedures when working with this device. Failure to observe this precaution may result in module damage or failure.

TYPICAL PERFORMANCE GRAPHS

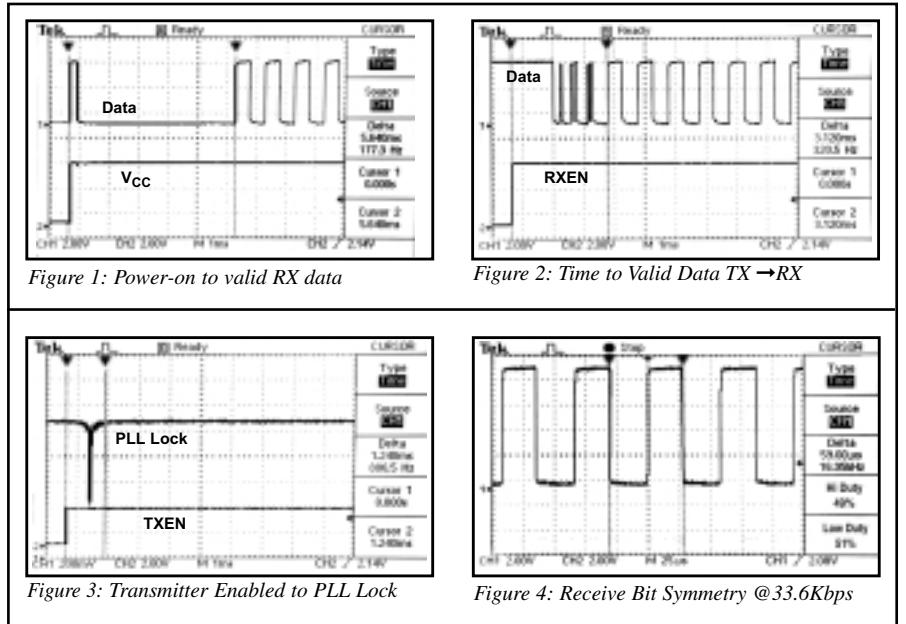

PIN DESCRIPTION

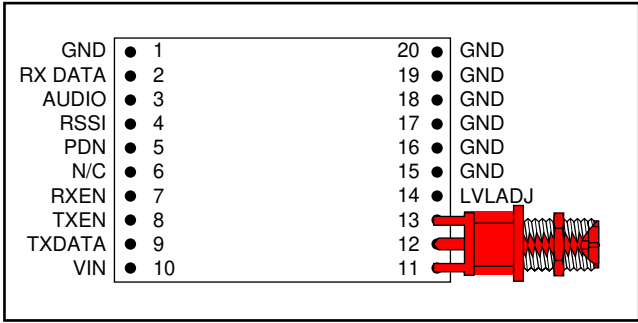

Figure 5: SC-PA Pinouts (viewed looking down on top cover)

PIN#	Pin Title	Description
1,11,13 15-20	Ground	Module Grounds Tie to Common Groundplane
2	RXDATA	Recovered Data Output
3	AUDIO	Recovered Analog Output
4	RSSI	Received Signal Strength Indicator
5	PDN	Logic Low Powers Down The Transceiver
6	N/C	Not Implemented Do Not Connect
7	RXEN	Receiver Enable Pin Active High Pull Low When in TX
8	TXEN	Transmitter Enable Pin Active High Pull Low When in RX
9	TXDATA	Analog or Digital Content to be Transmitted
10	VIN	2.7-13VDC Supply
12	ANT	50Ω Antenna Port TX/RX Switch Inside Module
14	LVLADJ	Open for Maximum TX Power Insert Resistor to Reduce by up to 5dB *Do Not Pull High*

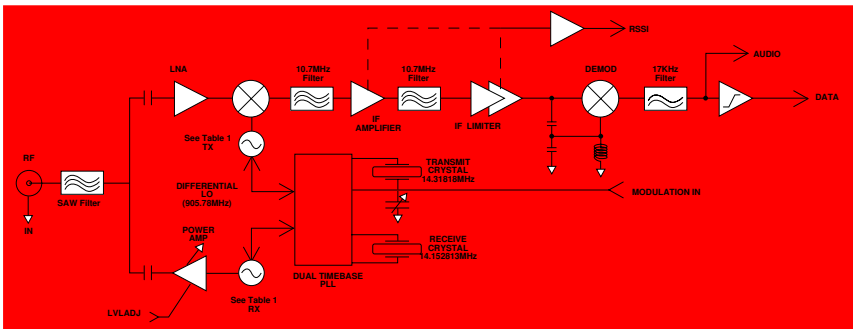

Figure 6: SC-PA Block Diagram

DESCRIPTION

The TR-XXX-SC-PA module is a single-channel, half-duplex transceiver designed for the wireless transmission of digital or analog information over distances of <300 feet outside and <150 feet inside. The PA version has a lower output power than the standard SC and has been pre-certified by the FCC which greatly reduces the time to market and cost of product introduction. No external components (excluding an antenna) are required. The module incorporates an on-board switch allowing the use of a single antenna. Linx offers a wide selection of antennas designed for use with the transceiver module.

The transceiver is half-duplex; therefore, it can only be operated in one mode at a time: either transmit mode or receive mode. When transmitting, the receiver is powered down. Likewise, the transmitter is powered down in receive mode.

The transmit section of the transceiver is capable of producing up to 1mW of output power while maintaining harmonics and spurious emissions within legal limits. The power amplifier can be adjusted over a 15dB adjustment range via the LVLADJ pin. This is very useful for optimizing a product during FCC testing.

The transmitter directly modulates the carrier with the baseband signal present at the TXDATA pin. If the signal is analog in nature, it will FM modulate the carrier. If the signal is digital, the modulation method becomes FSK. In either case the carrier's peak deviation is determined by the modulating signal's amplitude.

The receive section of the transceiver is capable of recovering a signal as low as -94dBm (typical). The receiver operates in a single conversion superhet configuration, with an IF of 10.7 MHz. A quadrature demodulator is used to recover the baseband analog signal from the carrier. This analog signal is low-pass filtered and then made externally available to the user via the audio pin. It is also passed to the data slicer for squaring of digital content.

The transceiver has an on-board voltage regulator that regulates the internal VCC to 3.0V. This allows a wide operating voltage range of 2.7V to 13V. At 2.7V, the internal regulator acts as a saturated switch, directly passing voltage through to the internal electronics. The PDN pin can be used to put the transceiver into a low-current sleep mode (<50uA).

TRANSMITTER OPERATION

The transceiver's transmitter section is a wide-band FM transmitter capable of generating -10dBm of output power into a 50-ohm load.

The transmitter is comprised of a VCO and a crystal-controlled frequency synthesizer. The frequency synthesizer, referenced to a precision crystal, locks the VCO to achieve a high-Q, low phase-noise oscillator.

FM modulation is achieved by direct modulation of the reference crystal. By modulating the transmitter in this manner, a wide modulation bandwidth is achieved. If the transmitter LO were modulated, the frequency synthesizer would track out modulation within the bandwidth of the loop filter (this is a common limitation of most synthesized FM transmitters).

When the transmitter will be used to transmit digital data, the TXDATA is best driven from a 5-volt source. The transmitter is designed to give an average deviation of 110kHz with a 5V square wave input. It is possible to successfully modulate the transceiver with a level as low as 3 volts; however, the reduced carrier deviation will cause a slight loss in receiver sensitivity and a 10 to 20% increase in settling times.

Analog sources such as audio should provide a 3V P-P maximum waveform and should be AC-coupled into the TXDATA pin. The size of the coupling capacitor should be large enough to insure the passage of all desired frequencies. Since the modulation voltage applied to the TXDATA pin determines the carrier deviation, distortion can occur if the TXDATA pin is over-driven. The actual level of the input waveform should be adjusted to achieve optimum in-circuit results.

The transmitter's output power is not affected by supply voltage but it can be externally adjusted. To ensure complete FCC compliance under every condition of operation, the SC-PA module is internally attenuated to a lower level than that of a standard SC module. If the user wishes to reduce the output power further, a resistor may be placed from the LVLADJ pin to ground. Depending on the value of resistor selected up to 5dB of additional attenuation may be realized. Under no circumstance should the pin be held high as the pre-certified status would be compromised and internal damage could result.

RECEIVER OPERATION

The receiver is configured as a single conversion superhet FM receiver with a baseband analog bandwidth of 17kHz.

Low-level RF signals are filtered at the front end by a SAW band-pass filter. This filter reduces the signal levels of interfering transmitters such as pager towers and cell phones.

The filtered signal is amplified and down-converted to the 10.7 MHz IF by mixing it with a LO frequency generated by a PLL locked differential VCO. Then the 10.7 MHz IF is amplified, filtered, and finally demodulated to recover the analog baseband signal originally transmitted. The analog baseband output is low-pass filtered and then made available externally via the audio pin. The signal is also squared by a proprietary data slicer for output of digital information at the RX Data pin. The data slicer is capable of recreating squared waveforms in the 150Hz to 17kHz band, giving a data-rate bandwidth of 300bps to 33.6Kbps.

The receiver features a RSSI output (Received Signal Strength Indicator). The RSSI pin gives a linear voltage output corresponding to incoming signal level. The RSSI output has many valuable uses including interference assessment, signal strength indication, external data squelching and qualification, and transmitter presence indication. Since RSSI values vary from part to part and correspond to signal strength and not necessarily distance, the pin is not recommended for range-finding applications.

When RF transmissions are not present, or when the received signal strength is too low to ensure proper demodulation, the data output is squelched to a continuous high state. This ensures compatibility with common serial UART's. It is important to note that the squelch level is set just over the transceiver's internal noise threshold and any external RF activity above that threshold will produce hashing on the transceiver output. While the data output is qualified high in low-noise environments, the designer should always plan for the potential of hashing. This is a key area of consideration when considering the overall protocol structure.

The two most obvious ways a wireless link differs from a wire are timing and susceptibility to interference. Brief reviews of each of these critical areas follows:

INTERFERENCE CONSIDERATIONS

It must be recognized that many bands are widely used, and the potential for conflict with other unwanted sources of RF is very real. Despite careful design, all RF products are at risk from interference.

Interference can manifest itself in many ways. Low-level interference will produce noise and hashing on the output and reduce the link's overall range. Thanks to the capture properties of an FM system, the transceiver will still function when an intended signal is present at a higher level than the interference.

Another type of interference can be caused by higher-powered devices such as hopping spread-spectrum devices. Since these devices move rapidly from frequency to frequency they will usually cause short, intense losses of information. Such errors are referred to as bursting errors and will generally be dealt with through protocol.

High-level interference is caused by products sharing the same frequency or from near-band high-power devices. Fortunately, this type of interference is less common than those mentioned previously, but in severe cases can prevent all useful function of the affected device.

Although technically it is not interference, multipath is also a factor to be understood. Multipath is a term used to refer to the signal cancelation effects that occur when RF waves arrive at the receiver in different phase relationships. This is particularly a factor in interior environments where objects provide many different reflection paths. Multipath results in lowered signal levels at the receiver and thus shorter useful distances for the link.

A spectrum analyzer is the primary tool of the RF engineer for assessing interference sources and levels, but is often not available due to its cost. Fortunately, the RSSI voltage output can also be used to determine the presence and strength of interference during the development process.

TIMING CONSIDERATIONS

There are three general areas of timing that are important to consider when designing with the transceiver: the actual time value for each is listed under the “Performance Specifications” section of this document.

1. Start-up time

Start-up time is the time to transmitter or receiver readiness from the application of power to the VIN pin on the PDN pin going high.

Transmitter readiness is defined as the presence of a fully locked carrier.

Receiver readiness is determined by valid data at the RXDATA pin. (This assumes an incoming data stream.)

2. Mode turnaround time

This is the time taken by a powered-up module to switch between modes.

The RX-to-TX time is measured as the time from the TXEN pin going high and the RXEN pin going low to the transmitter being ready to transmit data. Here again, transmitter readiness is defined as the presence of a fully locked carrier.

The TX-to-RX time is measured as the time from the RXEN pin going high and the TXEN pin going low to the receiver’s data output being valid. (This assumes valid incoming data.)

It is important to note that TXEN and RXEN should never be high at the same time. This will invalidate the timing parameters and may cause illegal emissions from the transceiver.

3. Required transition interval.

This is the maximum amount of time that can elapse without a transition on the TX data pin.

It is always important to think of data in both the analog and the digital domain. Because the data stream is asynchronous and no particular format is imposed, it is possible for the data to meet the baud-rate requirements of the module and yet violate the analog frequency parameters. For example, if a 255 (0FF hex) is being sent continuously the receiver would view the data as a DC level. The receiver would hold that level until a transition was required to meet the minimum frequency requirement. If no transition occurred, data integrity could not be guaranteed. Thus, while no particular signal structure or code-balancing requirement is imposed, the designer must insure that both analog and digital signals have transitions suitable to meet the required transition interval specification.

A TYPICAL SYSTEM EXAMPLE

To properly apply the transceiver, it is critical to understand and respect the differences that exist between a wired and a wireless environment. At every point in this system, there are timing and data-corruption issues that should be understood and accounted for. The following section provides a basic outline of the typical flow of events in a link incorporating SC-PA modules. While there are many alternate methodologies, this section illustrates many of the considerations previously mentioned.

It is important to note that the TR-XXX-SC-PA does not encode or packetize the data in any manner. This transparency eliminates the issues of variable latency common to traditional radio modems and gives the designer tremendous flexibility in the structure of protocol. A drawback to this approach is that the performance and reliability of the link is in part determined by the quality of external software and hardware.

The SC-PA is a half-duplex transceiver, meaning it can only act as a transmitter or a receiver at any given time, but never both. Designing a system with a half-duplex transceiver can be a bit challenging because of the timing requirements when shifting between transmit and receive modes. A typical systems operation would be similar to the following:

1) Switch to transmit mode

The transceiver is placed in transmit mode by bringing TXEN high and RXEN low. The PDN pin must be open or pulled to VCC. Once the transceiver is placed in transmit mode, the synthesizer will begin trying to lock.

2) Wait for transmitter to stabilize

This step is necessary to allow the transmitter time to lock and stabilize. Several options are available during this time. The designer might choose to set a fixed delay equal to the worst-case stabilization time before sending data. Another method would be to send data immediately, knowing that it would not be valid until the transmitter had stabilized. Depending on packet size, the latter method may achieve faster turnaround times but would require more care from a protocol standpoint.

3) Transmit a packet

Structuring the data to be sent into small packets is highly recommended. That way, errors can be managed easily without affecting large amounts of data. Packets should be transmitted so that there is no space between bytes. When using a UART the following packet format is generally followed:

[uart sync byte] [start byte] [data packet]

The UART Sync Byte is used to ensure that the start-bit for the start byte will be accurately detected. It is a single byte with a value of 255 (OFF hex).

A Start Byte often follows the Sync Byte to intelligently qualify the Data Packet which will follow. Detection of the Start Byte would be performed by the computer or microcontroller connected to the transceiver.

4) Switch to receive mode

The transceiver is placed in receive mode by bringing RXEN high and TXEN low. The PDN pin must be open or pulled to VCC. Once the transceiver is placed in receive mode, the PLL will begin trying to lock.

5) Wait for receiver to stabilize

This step is necessary to allow the receiver time to stabilize. When the PLL is locked and the data slicer is stable, the transceiver is ready to receive valid data. During the settling time the receiver output may produce scraps of data; however, the data can only be considered reliable once the settling time has passed.

6) Receive a packet

The procedure here is protocol-dependent but to illustrate, let's consider the packet format outlined above being sent to a UART. A UART interprets the start-bit of a byte as a 1-0 transition. When the incoming data is 101010 or hash... it is hard to actually find the start bit. This problem is solved by the UART Sync Byte. The purpose of the Sync Byte is to create a high marking period of at least a byte length so that the start bit of the following Start Byte can be correctly recognized.

The Start Byte following the Sync Byte is used by the receiving computer or microcontroller to intelligently identify the beginning of a data packet. The Start Byte value should be chosen so that it does not appear in the data stream. Otherwise, a receiver may "wake up" in the middle of a packet and interpret data in the packet as a valid Start Byte. There are many other, more complicated ways to organize the protocol if this restriction cannot be met.

There is always a possibility of bursting errors from interference or changing signal conditions causing corruption of the data packet, so some form of error checking should be employed. A simple checksum or CRC could be used. Once an error is detected the protocol designer may wish to simply discard the corrupt data or to develop a scheme for correcting it or requesting its retransmission.

The preceding steps indicate the general events involved in using the transceiver for a half-duplex communication application. To summarize, the system controller will basically run through the steps in order and then return to step 1, flipping back and forth between transmit and receive modes. As discussed, the designer must take into account the timing considerations of both the transmitting and receiving sides and carefully think through protocol issues to ensure product reliability under field conditions.

USING THE TR-XXX-SC-PA FOR AUDIO APPLICATIONS

The SC-PA is optimized for the transmission of serial data; however, it can also be used very effectively to send a variety of simple and complex analog signals including audio. The SC-PA is an excellent choice for applications requiring audio quality comparable to a radio or intercom. The ability of the SC-PA to send combinations of audio and data also opens new areas of opportunity for creative design. In applications which require high-quality audio, the SC-PA may be used with a compandor to further improve SNR. In the cases where truly high fidelity audio is required, the SC-PA will probably not be the best choice. For such applications, consider devices which have been optimized for audio.

The audio source should provide a 3V P-P maximum waveform and should be AC-coupled into the TXDATA pin. The size of the coupling capacitor should be large enough to insure the passage of all desired frequencies. Since the modulation voltage applied to the TXDATA pin determines the carrier deviation, distortion can occur if the TXDATA pin is over-driven. The actual level of the input waveform should be adjusted to achieve the optimum results for your application in your circuit.

The RXAUDIO output of the transceiver should be filtered and buffered to obtain maximum audio quality. For voice, a 3-4KHz low-pass filter is often employed. For broader-range sources such as music, a 12-17KHz cutoff may be more appropriate.

The SNR of the audio will depend on the bandwidth you select. The higher the SNR, the less "hiss" you will hear in the background. For the best SNR, choose the lowest filter cutoff appropriate for the intended signal.

POWER SUPPLY CONSIDERATIONS

The user must provide a clean source of power to the module to ensure proper operation. Power-supply noise will manifest itself as AM and FM noise and can significantly affect transceiver performance. Providing a clean power supply for the module should be a high design priority.

The TR-XXX-SC-PA incorporates an on-board Low-Dropout Regulator allowing the module to operate over an input voltage range of 2.7 to 13 volts DC. The module's power-supply line should have bypass capacitors configured as shown in figure 7. Actual capacitor values will vary depending on noise conditions.

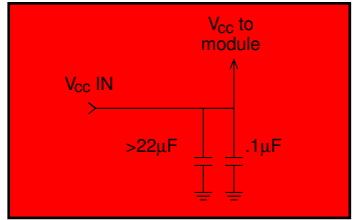

Figure 7: Suggested supply filter

BOARD LAYOUT CONSIDERATIONS

If you are at all familiar with RF devices, you may be concerned about specialized layout requirements. Fortunately, because of the care taken by Linx in the layout of the module's PCB, integrating a TR-XXX-SC-PA transceiver into your design is very straightforward. By adhering carefully to a few basic design and layout rules, you can enjoy a trouble-free path to RF success.

Figure 8 shows the suggested PCB footprint for the TR-XXX-SC-PA.

A groundplane (as large as possible) should be placed directly under the TR-XXX-SC-PA. This groundplane can also be critical to the performance of your antenna.

The SC-PA should, as much as reasonably possible, be isolated from all other components on your PCB. Specifically, high-frequency circuitry such as crystal oscillators should be kept as far away as possible from the module.

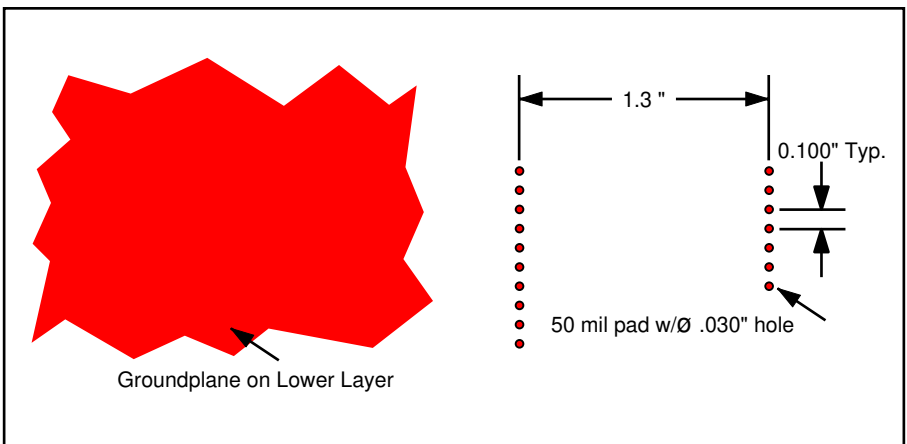

Figure 8: Recommended PCB layout

ANTENNA CONSIDERATIONS

The SC-PA transceivers feature a unique RP-SMA antenna connector. This connector is designed to allow the convenience and flexibility of a detachable antenna while maintaining compliance with FCC guidelines.

Linx and other manufacturers sell a variety of antenna styles and connectors designed to mate with the module's RP-SMA connection. It is important to note, however, that the module must be used with the appropriate Linx antennas in order to retain its pre-approved status. Other antennas may be used; however, recertification would be necessary prior to offering the product for sale. The antennas pictured below illustrate styles that would be commonly employed. Please contact Linx or visit www.linxtechnologies.com for the most current information on compliant antenna styles.

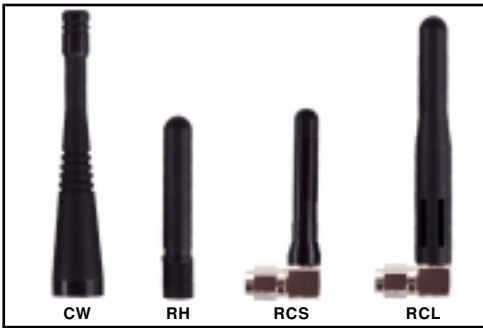

Figure 9: Compatible Linx Antenna Styles

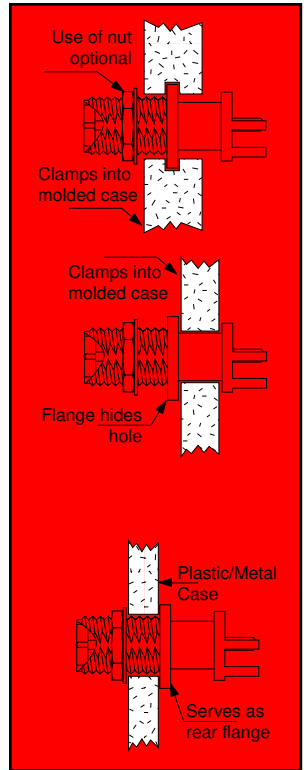

Figure 10: Mounting Options

The following general rules should help in maximizing antenna performance:

1. Proximity to objects such as a user's hand or body, or metal objects will cause an antenna to detune. For this reason the antenna shaft and tip should be positioned as far away from such objects as possible.
2. Keep the antenna away from other metal components, particularly large items like transformers, batteries, and PCB tracks and ground-planes. The space around the antenna can be as important as the antenna itself.
3. The ground-plane acts as a counterpoise, forming, in essence, a 1/2-wave dipole. For this reason adequate ground-plane area is essential. As a general rule the ground-plane to be used as counterpoise should have a surface area \geq the overall length of the 1/4-wave radiating element.
4. Remove the antenna as far as possible from potential interference sources. Any frequency of sufficient amplitude to enter the receiver's front end will reduce system range, cause increased bit errors, and can even prevent reception entirely. There are many possible sources of internally generated interference. Switching power supplies, oscillators, even relays can also be significant sources of potential interference.

Power Conversion Tables For 50Ω System

dBm	mW	dBmV	mVRMS	mVp	mVpp
-50	0.000	-3.0	0.7	1.0	2.0
-45	0.000	2.0	1.3	1.8	3.6
-40	0.000	7.0	2.2	3.2	6.3
-35	0.000	12.0	4.0	5.6	11.2
-30	0.001	17.0	7.1	10.0	20.0
-25	0.003	22.0	12.6	17.8	35.6
-20	0.010	27.0	22.4	31.6	63.2
-15	0.032	32.0	39.8	56.2	112.5
-10	0.100	37.0	70.7	100.0	200.0
-5	0.316	42.0	125.7	177.8	355.7
0	1.000	47.0	223.6	316.2	632.5
1	1.259	48.0	250.9	354.8	709.6
2	1.585	49.0	281.5	398.1	796.2
3	1.995	50.0	315.9	446.7	893.4
4	2.512	51.0	354.4	501.2	1002.4
5	3.162	52.0	397.6	562.3	1124.7
6	3.981	53.0	446.2	631.0	1261.9
7	5.012	54.0	500.6	707.9	1415.9
8	6.310	55.0	561.7	794.3	1588.7
9	7.943	56.0	630.2	891.3	1782.5
10	10.000	57.0	707.1	1000.0	2000.0
11	12.589	58.0	793.4	1122.0	2244.0
12	15.849	59.0	890.2	1258.9	2517.9
13	19.953	60.0	998.8	1412.5	2825.1
14	25.119	61.0	1120.7	1584.9	3169.8
15	31.623	62.0	1257.4	1778.3	3556.6
16	39.811	63.0	1410.9	1995.3	3990.5
17	50.119	64.0	1583.0	2238.7	4477.4
18	63.096	65.0	1776.2	2511.9	5023.8
19	79.433	66.0	1992.9	2818.4	5636.8
20	100.000	67.0	2236.1	3162.3	6324.6
21	125.893	68.0	2508.9	3548.1	7096.3
22	158.489	69.0	2815.0	3981.1	7962.1
23	199.526	70.0	3158.5	4466.8	8933.7
24	251.189	71.0	3543.9	5011.9	10023.7
25	316.228	72.0	3976.4	5623.4	11246.8
26	398.107	73.0	4461.5	6309.6	12619.1
27	501.187	74.0	5005.9	7079.5	14158.9
28	630.957	75.0	5616.7	7943.3	15886.6
29	794.328	76.0	6302.1	8912.5	17825.0
30	1000.000	77.0	7071.1	10000.0	20000.0

LEGAL CONSIDERATIONS

The TR-916-SC-PA module has been previously tested and received certification as a modular product from the FCC. No further testing of the module is necessary when compliant antennas are employed. The pre-certified status of the module is valid only if all of the following are observed:

- No modifications to the module may be made.
- The module must utilize Linx antennas which have been previously tested with the module and approved for FCC compliance.
- The pre-certified status applies only to the RF module. The user must determine if additional certification or testing is required for peripheral circuitry.
- If the transceiver's own label is not visible when installed inside another device then the device must display an external label referring to the enclosed module. The exterior label should appear as follows:

This device contains a previously certified RF Transceiver module FCC ID:OJM-TR-916-SC-PA
--

The product's instruction manual must display the following statement:

INSTRUCTION TO THE USER

This equipment contains an RF module which has been previously tested and found to comply with the limits for a Class B digital device, pursuant to Part 15 of the FCC Rules. These limits are designed to provide reasonable protection against harmful interference in a residential installation. This equipment generates, uses and can radiate radio frequency energy and if not installed and used in accordance with the instructions, may cause harmful interference to radio communications. However, there is no guarantee that interference will not occur in a particular installation. If this equipment does cause harmful interference to radio or television reception, which can be determined by turning the equipment off and on, the user is encouraged to try to correct the interference by one or more of the following measures:

Reorient or relocate the receiving antenna.

Increase the separation between the equipment and receiver.

Connect the equipment into an outlet on a circuit different from that to which the receiver is connected.

Consult the dealer or an experienced radio/TV technician for help.

This equipment has been certified to comply with the limits for a Class B computing device, pursuant to FCC Rules. In order to maintain compliance with FCC regulations, shielded cables must be used with this equipment. Operation with non-approved equipment or unshielded cables is likely to result in interference to radio and TV reception. The user is cautioned that changes and modifications made to the equipment without the approval of manufacturer could void the user's authority to operate this equipment.

NOTE: SC-PA Modules are pre-approved by the FCC for operation within the United States; however, they are not approved by other agencies worldwide. The purchaser should understand that additional approvals may be required prior to the sale or operation of the device, and agrees to utilize the component in keeping with all applicable laws in the country of operation.

Questions regarding domestic rules should be addressed to:

Federal Communications Commission
Equipment Authorization Division
Customer Service Branch, MS 1300F2
7435 Oakland Mills Road
Columbia, MD 21046

Tel: (301) 725-1585 / Fax: (301) 344-2050 E-Mail: labinfo@fcc.gov

ACHIEVING A SUCCESSFUL RF IMPLEMENTATION

Adding wireless capabilities brings an exciting new dimension to any product. By utilizing Linx pre-certified RF modules the cost, effort, and time necessary to bring your product to market will be greatly reduced. By choosing Linx as your RF partner and taking advantage of the resources we offer, you will not only survive implementing RF, but you may even find the process enjoyable.

HELPFUL APPLICATION NOTES FROM LINX

It is not the intention of this manual to address in depth many of the issues that should be considered to ensure that the modules function correctly and deliver the maximum possible performance. As you proceed with your design you may wish to obtain one or more of the following application notes, which address in depth key areas of RF design and application of Linx products.

NOTE #	LINX APPLICATION NOTE TITLE
00500	Antennas: Design, Application, Performance
00130	Modulation techniques for low-cost RF data links
00126	Considerations for operation in the 902 Mhz to 928 Mhz band
00100	RF 101: Information for the RF challenged
00140	The FCC Road: Part 15 from concept to approval
00150	Use and design of T-Attenuation Pads
00102	RS-232 A brief overview
00161	Considerations for sending data with the SC Series*

* =Not available at the time of this printing



U.S. CORPORATE HEADQUARTERS:

LINX TECHNOLOGIES, INC.

**575 S.E. ASHLEY PLACE
GRANTS PASS, OR 97526**

Phone: (541) 471-6256

FAX: (541) 471-6251

<http://www.linxtechnologies.com>

Disclaimer

Linx Technologies is continually striving to improve the quality and function of its products; for this reason, we reserve the right to make changes without notice. The information contained in this Data Sheet is believed to be accurate as of the time of publication. Specifications are based on representative lot samples. Values may vary from lot to lot and are not guaranteed. Linx Technologies makes no guarantee, warranty, or representation regarding the suitability of any product for use in a specific application. None of these devices is intended for use in applications of a critical nature where the safety of life or property is at risk. The user assumes full liability for the use of product in such applications. Under no conditions will Linx Technologies be responsible for losses arising from the use or failure of the device in any application, other than the repair, replacement, or refund limited to the original product purchase price. Some devices described in this publication are patented. Under no circumstances shall any user be conveyed any license or right to the use or ownership of these patents.

© 2001 by Linx Technologies, Inc. The stylized Linx logo, Linx, and "Wireless made Simple" are the trademarks of Linx Technologies, Inc.
Printed in U.S.A.