



Chipsmall Limited consists of a professional team with an average of over 10 year of expertise in the distribution of electronic components. Based in Hongkong, we have already established firm and mutual-benefit business relationships with customers from,Europe,America and south Asia,supplying obsolete and hard-to-find components to meet their specific needs.

With the principle of “Quality Parts,Customers Priority,Honest Operation,and Considerate Service”,our business mainly focus on the distribution of electronic components. Line cards we deal with include Microchip,ALPS,ROHM,Xilinx,Pulse,ON,Everlight and Freescale. Main products comprise IC,Modules,Potentiometer,IC Socket,Relay,Connector.Our parts cover such applications as commercial,industrial, and automotives areas.

We are looking forward to setting up business relationship with you and hope to provide you with the best service and solution. Let us make a better world for our industry!



Contact us

Tel: +86-755-8981 8866 Fax: +86-755-8427 6832

Email & Skype: info@chipsmall.com Web: www.chipsmall.com

Address: A1208, Overseas Decoration Building, #122 Zhenhua RD., Futian, Shenzhen, China





150W TRV-150 Series

Switch Mode LED Drivers

Constant Voltage

Aluminum Housing

Electrical Specifications

Input Voltage Range:	100 - 277 Nom. Vac (90 - 305 V Min/Max)
Frequency:	50/60 Hz Nom. (47-63 Hz Min/Max)
Power Factor:	0.90 @ 75-100% load, 100-277V
THD:	≤ 20% @ 75-100% load, 100-277V
Inrush Current:	65 Amps maximum @ 230 Vac, cold start 25°C
Input Current:	1.75 A max 100Vac, 0.8 A max 220Vac
Maximum Power:	150W
Line Regulation:	± 1%
Load Regulation:	± 2%
Leakage Current:	1 mA 277 Vac 60Hz
Typical Efficiency	92.5%-93.5% at 220Vac
Turn-on Delay:	0.9S typical 110Vac, 0.5S typical 220Vac
Ripple and Noise:	2% V _o
Protection:	Over-Voltage (latch mode), Over-Temperature (110°C), Over-Current (hiccup mode), Lightning, and Short Circuit Protection with Self Recovery

Environmental Specifications

Minimum Starting Temp:	-35°C
Maximum Case Temp.	90°C
Storage Temperature:	-40°C to +85°C
Humidity:	5% to 100%
Cooling:	Convection
Sound Rating:	Class A
MTBF:	260,000 Hours @ 110Vac input, 80% load and 25°C ambient conditions per MIL-HDBK-217F
Lifetime:	77,200 Hours @ 220Vac, 80% load and Tc=60°C
Weight:	2.2 lbs. (1.0 kg)



- Total Power: 150 Watts
- Input Voltage: 100-277 Vac Nom.
- UL Dry & Damp Location Rated
- IP67
- Ultra-high Efficiency
- High Power Factor
- UL8750

New Surge Protection and HI-POT Testing



HI-POT Test

Normal Application

The new design of this LED driver provides 1.4KV surge protection. To properly HI-POT test this unit, the surge protection must be disconnected. The screw, nut, and metal lock sheet on the input side of the driver provide for this. To test, first remove the nut and lock sheet as shown. After testing, secure the nut and lock sheet to provide line-to-earth protection.

This HI-POT test feature is available on product manufactured after August 15, 2015.

Model Number	Output Voltage (Vdc ±5%)	Output Current Range (mA)	Max. Output Power (W)	Typical Efficiency
TRV-150S012ST	12	0-12.5	150	92%
TRV-150S020ST	20	0-7.50	150	92%
TRV-150S024ST	24	0-6.25	150	93%
TRV-150S036ST	36	0-4.17	150	93%
TRV-150S048ST	48	0-3.13	150	93%
TRV-150S054ST	54	0-2.78	150	93%

Safety and EMC Compliance

UL/CUL	UL8750, Compliance to UL1012, UL935, CAN/CSA-C22.2 No. 0, CSA-C22.2 No. 107.1-01, CSA-C22.2 No. 250.0
C E	EN 61347-1, EN61347-2-13
EN 55015	Conducted emission Test & Radiated emission Test
EN 61000-3-2	Harmonic current emissions
EN 61000-3-3	Voltage fluctuations & flicker
EN 61000-4-2	Electrostatic Discharge (ESD): 8 kV air discharge, 4 kV contact discharge
EN 61000-4-3	Radio-Frequency Electromagnetic Field Susceptibility Test-RS
EN 61000-4-4	Electrical Fast Transient / Burst-EFT
EN 61000-4-5	Surge Immunity Test: AC Power Line: line to line 4 kV, line to earth 6 kV
EN 61000-4-6	Conducted Radio Frequency Disturbances Test-CS
EN 61000-4-8	Power Frequency Magnetic Field Test
EN 61000-4-11	Voltage Dips
EN 61547	Electromagnetic Immunity Requirements Applies to Lighting Equipment



Note:

LED drivers are designed and intended to operate LED loads only. Non-LED loading may be outside the specified design limits of our LED drivers, and therefore cannot be covered by any warranty. If you desire to use our LED drivers to operate non-LED loads please contact us to discuss compatibility.

Specifications subject to change without notice.

Rev 8-28-15

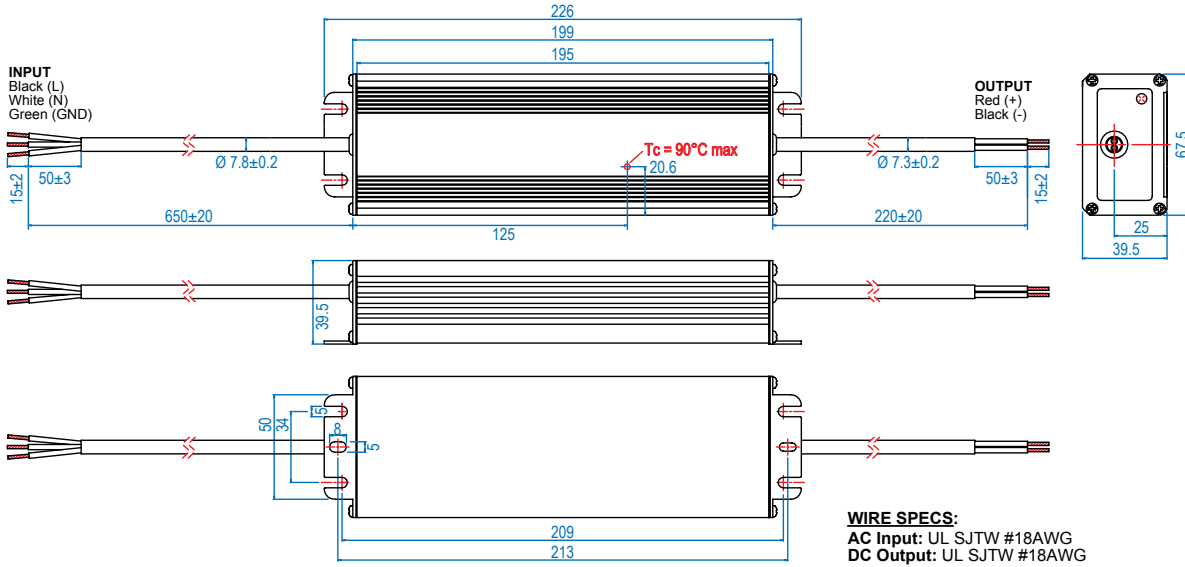

TRV-150S012ST:

Note: Two DC output cables are connected in parallel internally, because one AWG #18 wire can only carry 10A. In application, connect the two red wires together and two black wires together, or ensure that each cable carries same current.

