



Chipsmall Limited consists of a professional team with an average of over 10 year of expertise in the distribution of electronic components. Based in Hongkong, we have already established firm and mutual-benefit business relationships with customers from,Europe,America and south Asia,supplying obsolete and hard-to-find components to meet their specific needs.

With the principle of “Quality Parts,Customers Priority,Honest Operation,and Considerate Service”,our business mainly focus on the distribution of electronic components. Line cards we deal with include Microchip,ALPS,ROHM,Xilinx,Pulse,ON,Everlight and Freescale. Main products comprise IC,Modules,Potentiometer,IC Socket,Relay,Connector.Our parts cover such applications as commercial,industrial, and automotives areas.

We are looking forward to setting up business relationship with you and hope to provide you with the best service and solution. Let us make a better world for our industry!



Contact us

Tel: +86-755-8981 8866 Fax: +86-755-8427 6832

Email & Skype: info@chipsmall.com Web: www.chipsmall.com

Address: A1208, Overseas Decoration Building, #122 Zhenhua RD., Futian, Shenzhen, China



PART
NAME

TEM-STAT TEMPERATURE CONTROL

PART
No.

TS-16

REV.
DATE

-

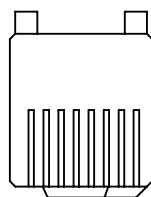

MATERIALS:
HOUSING - PLASTIC, UL 94V-0, HOUSING - LIGHT GREY
DIAL - BLUE
SENSOR ELEMENT - THERMOSTATIC BI-METAL

UL, CSA AGENCY APPROVED
MOUNTS TO 35mm DIN RAIL (EN 60 715)

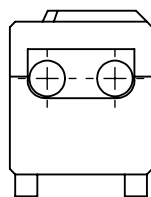
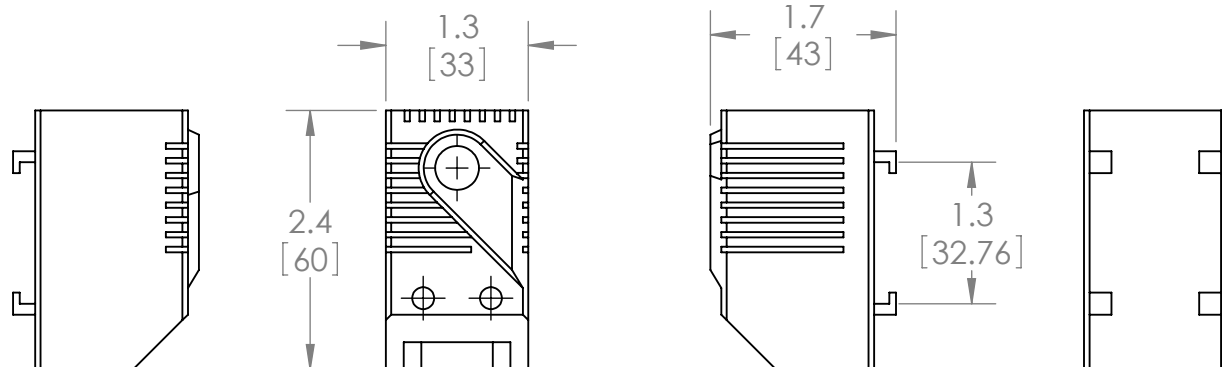

SPECIFICATIONS:
NORMALLY OPEN, CLOSURES ON TEMPERATURE RISE
TEMPERATURE SETTING RANGE: +32 to +140°F (0 to +60°C)
SWITCHING DIFFERENCE (HYSTERESIS): 12.6°F ± 7°F (7°C ± 4K)
MAX. TOLERANCE: ±7.2°F (4K)
SERVICE LIFE: 100,000 CYCLES AT 120 VAC, 30,000 CYCLES AT 240 VAC
SWITCHING CAPACITY (MAX. LOAD): 15A RESISTIVE/ 2A INDUCTIVE AT 120 VAC
10A RESISTIVE/ 2A INDUCTIVE AT 250 VAC
DC 30W

MINIMUM LOAD: 20mA (ALL VOLTAGES)
EMI/EMC COMPLIANCE: EN 55014-1-2, EN 61000-3-2, EN 61000-3-3
CONTACT TYPE: SNAP-ACTION CONTACT
CONNECTION: 2-POLE TERMINAL, CLAMPING TORQUE 0.5Nm MAX.

SOLID WIRE - AWG 14 MAX. (2.5mm²)

STRANDED WIRE (WITH WIRE END FERRULE) - AWG 16 (1.5mm²)

WEIGHT: APPROX. 1.4 oz. (40g)
OPERATING TEMPERATURE: -4 to +176°F (-20 to +80°C)
STORAGE TEMPERATURE: -49 to +176°F (-45 to +80°C)
PROTECTION TYPE: IP20
SCALE ON HOUSING: +32 to +140°F

