



Chipsmall Limited consists of a professional team with an average of over 10 year of expertise in the distribution of electronic components. Based in Hongkong, we have already established firm and mutual-benefit business relationships with customers from,Europe,America and south Asia,supplying obsolete and hard-to-find components to meet their specific needs.

With the principle of “Quality Parts,Customers Priority,Honest Operation,and Considerate Service”,our business mainly focus on the distribution of electronic components. Line cards we deal with include Microchip,ALPS,ROHM,Xilinx,Pulse,ON,Everlight and Freescale. Main products comprise IC,Modules,Potentiometer,IC Socket,Relay,Connector.Our parts cover such applications as commercial,industrial, and automotives areas.

We are looking forward to setting up business relationship with you and hope to provide you with the best service and solution. Let us make a better world for our industry!



Contact us

Tel: +86-755-8981 8866 Fax: +86-755-8427 6832

Email & Skype: info@chipsmall.com Web: www.chipsmall.com

Address: A1208, Overseas Decoration Building, #122 Zhenhua RD., Futian, Shenzhen, China



TSTFT3.5Z

(Touch Panel)

RoHS Compliant

For product support, contact

Newhaven Display International
2511 Technology Drive #101
Elgin, IL 60124
Tel: (847) 844-8795 Fax: (847) 844-8796

March 31, 2010

RevNo	Revision note	Date	Signature	Checked
-------	---------------	------	-----------	---------

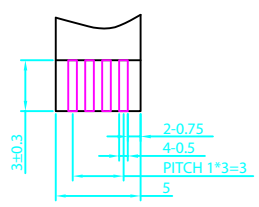
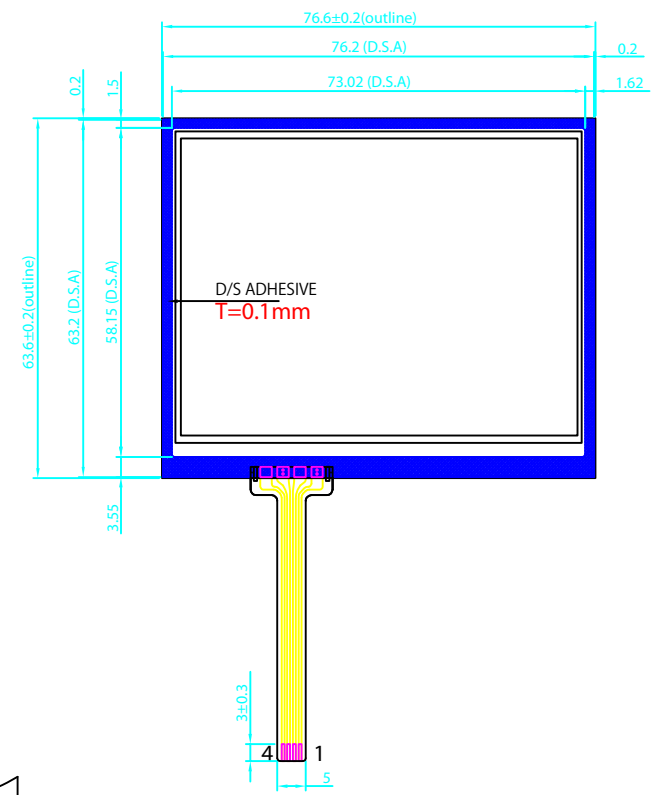
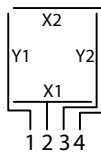
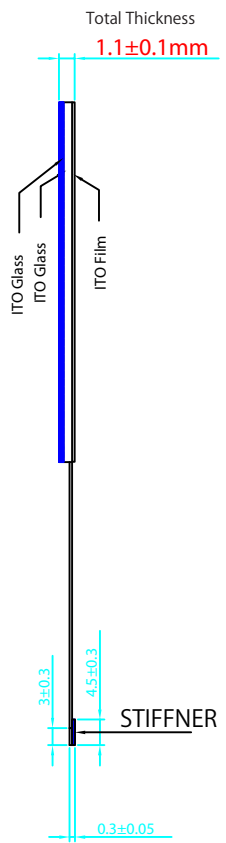
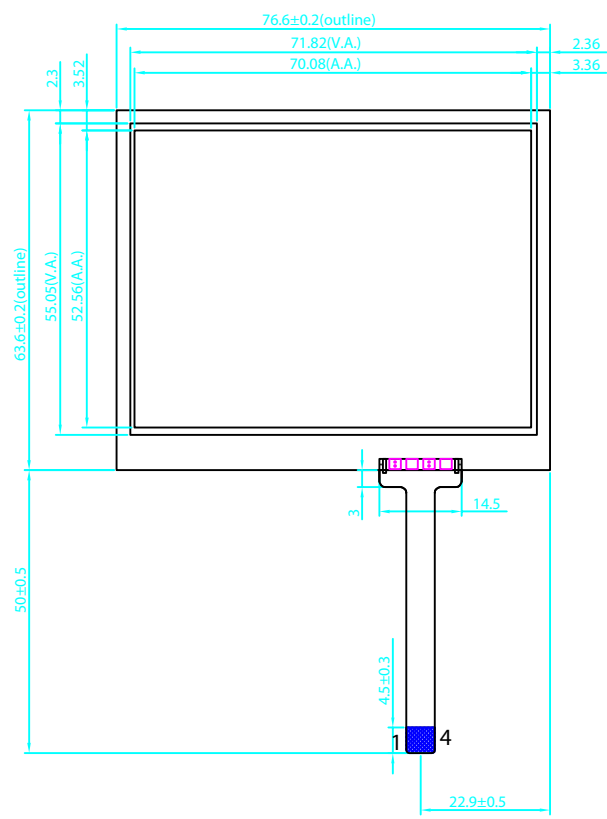

- 1 . GLASS THICKNESS: 0.7mm
- 2 . Operating Temperature: - 10°C~+60°C, Storage Temperature:- 20°C~+70°C
- 3 . Linearity: $\leq \pm 1.5\%$
- 4 . Transmittance: $>75\%$
- 5 . Circuit Resistance: X:200~900Ω, Y: 200~900Ω
- 6 . Surface Hardness: ($\geq 3H$)
- 7 . Durability: $>1,000,000$ Touches
- 8 . RoHS

THIRD ANGLE PROJECTION		Dimensions	Scale	Newhaven Display International	
		mm	1:1		
NAME	DATE				
APPROVE	2010.03.31	Dwg Name	Dwg No.		
CHECK	2010.03.31	Touch Panel	TSTFT3.5Z		
DESIGN	2010.03.30	Customer Name	Customer No.		
DRAWN	2010.03.30				