



Chipsmall Limited consists of a professional team with an average of over 10 year of expertise in the distribution of electronic components. Based in Hongkong, we have already established firm and mutual-benefit business relationships with customers from,Europe,America and south Asia,supplying obsolete and hard-to-find components to meet their specific needs.

With the principle of “Quality Parts,Customers Priority,Honest Operation,and Considerate Service”,our business mainly focus on the distribution of electronic components. Line cards we deal with include Microchip,ALPS,ROHM,Xilinx,Pulse,ON,Everlight and Freescale. Main products comprise IC,Modules,Potentiometer,IC Socket,Relay,Connector.Our parts cover such applications as commercial,industrial, and automotives areas.

We are looking forward to setting up business relationship with you and hope to provide you with the best service and solution. Let us make a better world for our industry!



Contact us

Tel: +86-755-8981 8866 Fax: +86-755-8427 6832

Email & Skype: info@chipsmall.com Web: www.chipsmall.com

Address: A1208, Overseas Decoration Building, #122 Zhenhua RD., Futian, Shenzhen, China



REVISION NOTE

The current revisions for the TS1003 Demo Boards display the identifier TS100x Demo Board on the top side of the evaluation board as depicted in Figure 1. If the identifier is not printed on the top side of the evaluation board, please contact Silicon Labs for support at:

<https://www.silabs.com/support/pages/contacttechnicalsupport.aspx>

COMPONENT LIST

DESIGNATION	QTY	DESCRIPTION
C1, C2, C3, C5	4	0.1 μ F \pm 10% capacitors (0805)
C4, C6	2	1 μ F \pm 10% capacitors (0805)
R2	1	665k Ω \pm 1% resistor (0805)
R7	1	500k Ω \pm 1% resistor (0805)
R5, R6, R10	3	1M Ω \pm 1% resistors (0805)
R8, R9	2	1.25M Ω \pm 1% resistors (0805)
R1, R3, R4	3	2M Ω \pm 1% resistors (0805)
U1, U2	2	TS1003 operational amplifiers
V _{DD} , V _{in} , V _{out} , GND	11	Test points

FEATURES

- 0.8V to 5.5V Single-supply operation
- AC-coupled Non-Inverting and Inverting configuration supplied
- Fully Assembled and Tested
- 2in x 2in 2-layer demo board

DESCRIPTION

The demo board for the TS1003 is a completely assembled and tested circuit board that can be used for evaluating the TS1003. The TS1003 is the industry's first sub-1 μ A supply current, precision CMOS operational amplifier fully specified to operate over a supply voltage range from 0.8V to 5.5V. Fully specified at 1.8V, the TS1003 is optimized for ultra-long-life battery powered applications. The TS1003 exhibits a typical input bias current of 2pA, and rail-to-rail input and output stages.

The TS1003 is fully specified over the industrial temperature range (-40°C to +85°C). The TS1003 evaluation board is offered with either a PCB-space saving 5-lead SC70 or 5-lead SOT23 packaging.

Product data sheets and additional documentation can be found at www.silabs.com.

Ordering Information

Order Number	Description
TS1003DB	SC70 Packaging Demo Board
TS1003DB-SOT	SOT23 Packaging Demo Board



Figure 1. TS1003 Evaluation Board Top View



Figure 2. TS1003 Evaluation Board Bottom View

Description

The TS1003 evaluation boards provide two configurations for evaluating the TS1003 operational amplifier in one single PCB board, namely a non-inverting configuration located on the left-hand side of the board and an inverting configuration located on the right-hand side of the board. In both cases, the input to each circuit is AC-coupled. The demo board provides a re-biasing scheme at one-half the power supply or $V_{DD}/2$ for the inverting configuration and at $V_{DD}/4$ for the non-inverting configuration.

The TS1003 demo board provides a dedicated power supply for the non-inverting circuit and a dedicated power supply for the inverting circuit. This provides the user the flexibility of evaluating one circuit at a time or both at the same time.

In both the non-inverting and the inverting configuration, the AC-coupling capacitor creates a high pass filter. The resulting cut-off frequency, f_c , is given as:

$$f_c = \frac{1}{2\pi RC}$$

In the non-inverting circuit, $R=R5=1M\Omega$ and $C=C5=0.1\mu F$. In the inverting case, $R=R10=1M\Omega$ and $C=C1=0.1\mu F$. In both cases, these component values generate a high-pass cut-off frequency of 1.6Hz.

Default Configurations

Non-Inverting configuration

In the non-inverting configuration, the circuit's transfer function is given by the following equation:

$$\frac{V_{OUT}}{V_{IN}} = 1 + \frac{R4}{R3}$$

With $R4=2M\Omega$ and $R3=2M\Omega$ the circuit signal gain is 2 with a circuit bandwidth of 2kHz. This results in an overall circuit bandwidth range of 1.6Hz to 2kHz.

Inverting configuration

In an inverting configuration, the circuit's transfer function is given by the following equation:

$$\frac{V_{OUT}}{V_{IN}} = - \frac{R6}{R10}$$

In this case, $R6=1M\Omega$ and $R10=1M\Omega$. This results in a signal gain of -1 with a circuit bandwidth of 2kHz and an overall circuit bandwidth range of 1.6Hz to 2kHz.

Quick Start Procedures

Required Equipment

- TS1003 demo board
- DC Power Supply, Single or Dual Output
- Function Generator
- 4-channel Oscilloscope
- Two $1M\Omega$ oscilloscope probes

Non-Inverting Configuration

In order to evaluate the TS1003 operational amplifier in the non-inverting configuration, the following steps are to be performed:

- 1) Before connecting the DC power supply to the demo board power test points, turn on the power supply and set the DC voltage to 5.5V and then turn it off.
- 2) Set the function generator frequency to 500Hz and output level with a $V_{OH} = 2.35V$ and a $V_{OL} = 2.15V$. This sets the input signal swing to $200mV_{PP}$, centered at 2.25V.
- 3) In order to monitor the input and output signal, select two channels on the oscilloscope and set the vertical voltage scale and the vertical position on each channel to 100mV/DIV and -2.25V, respectively. Set the horizontal time scale to 500 μs /DIV.
- 4) Connect the positive terminal of the DC power supply to V_{DD} and the ground terminal to GND.

- 5) Connect the signal output of the function generator to V_{in} and the ground terminal to GND.
- 6) To monitor the input, connect the signal terminal of one of the oscilloscope probes to V_{in} and the ground terminal to GND. To monitor the output, use the second probe to connect the signal terminal to V_{OUT} and the ground terminal to GND.
- 7) Turn on the power supply and check that the power supply current is approximately $3.6\mu A$.
- 8) Turn on the function generator.
- 9) Observe the input and output signal. The output signal is an amplified version of the input signal with an output swing of approximately $400mV_{PP}$, corresponding to a signal gain of two.

Inverting Configuration

In order to evaluate the TS1003 operational amplifier in the inverting configuration, the following steps are to be performed:

- 1) Before connecting the DC power supply to the demo board, turn on the power supply and set the DC voltage to 5.5V and then turn it off.
- 2) Set the function generator output frequency to 500Hz and output level with a $V_{OH} = 2.35V$ and a

$V_{OL} = 2.15V$. This sets the input swing to $200mV_{PP}$, centered at 2.25V.

- 3) In order to monitor the input and output signal, select two channels on the oscilloscope and set the vertical voltage scale and the vertical position on each channel to $100mV/DIV$ and $-2.25V$, respectively. Set the horizontal time scale to $500\mu s/DIV$.
- 4) Connect the positive terminal of the DC power supply to VDD and the ground terminal to GND.
- 5) Connect the signal output of the function generator to V_{in} and the ground terminal to GND.
- 6) To monitor the input, connect the signal terminal of one of the oscilloscope probes to V_{in} and the ground terminal to GND. To monitor the output, use the second probe to connect the signal terminal to V_{OUT} and the ground terminal to GND.
- 7) Turn on the power supply and check that the power supply current is approximately $3.0\mu A$.
- 8) Turn on the function generator.
- 9) Observe the input and output signal. The output signal is an inverted version of the input signal and the swing should be $200mV_{PP}$.

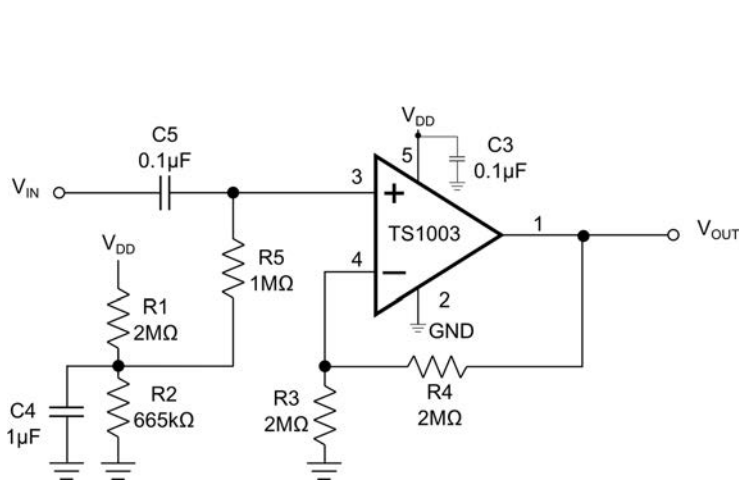

Figure 3. Non-Inverting Configuration

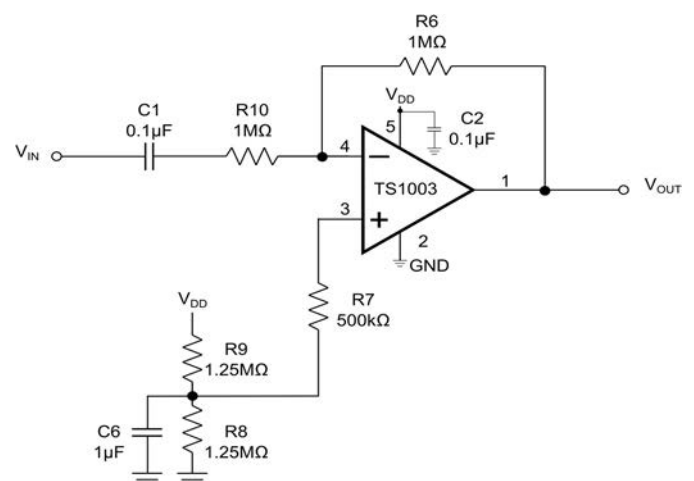

Figure 4. Inverting Configuration

TS1003 Demo Board

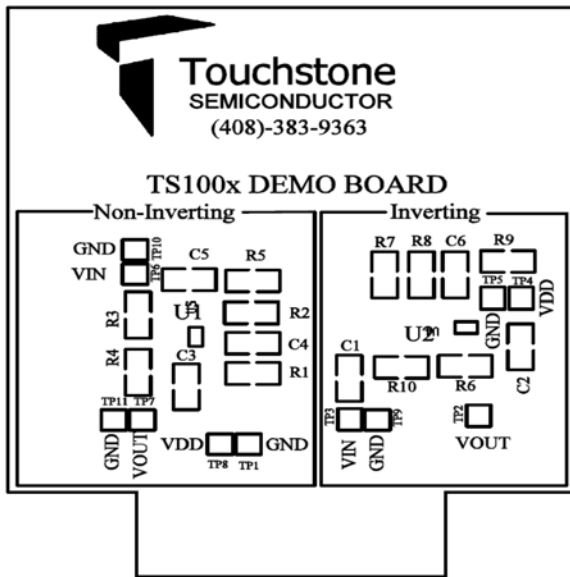

Figure 5. TS1003 Demo Board
Top Layer #1

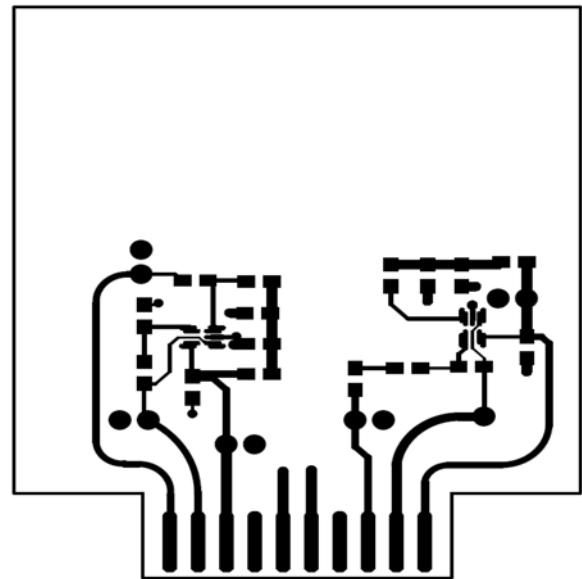

Figure 6. TS1003 Demo Board
Top Layer #2

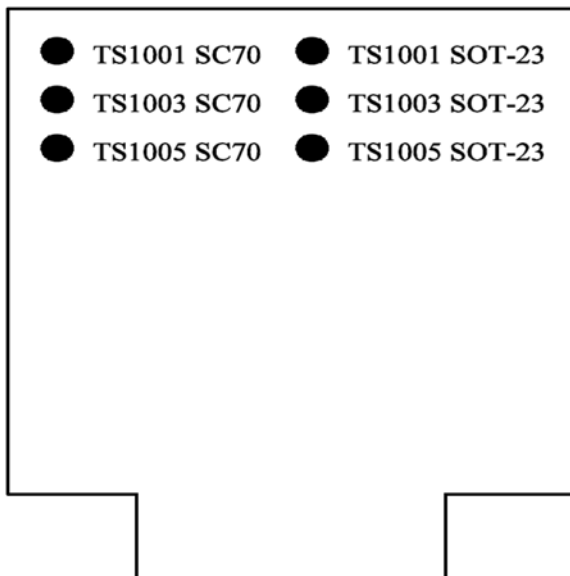

Figure 7. TS1003 Demo Board
Bottom Layer (GND) #1

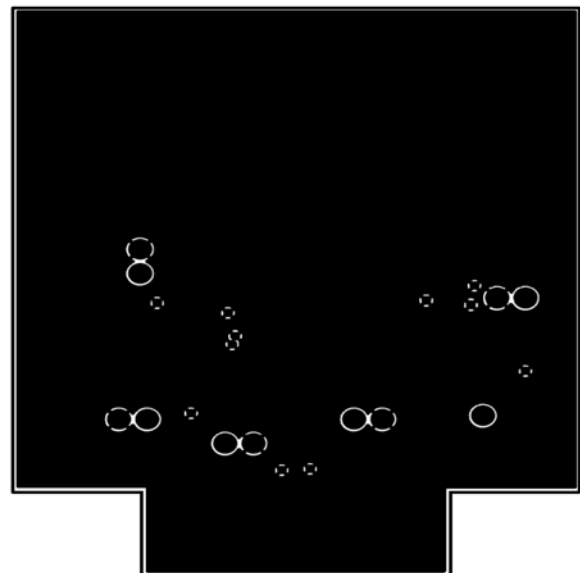
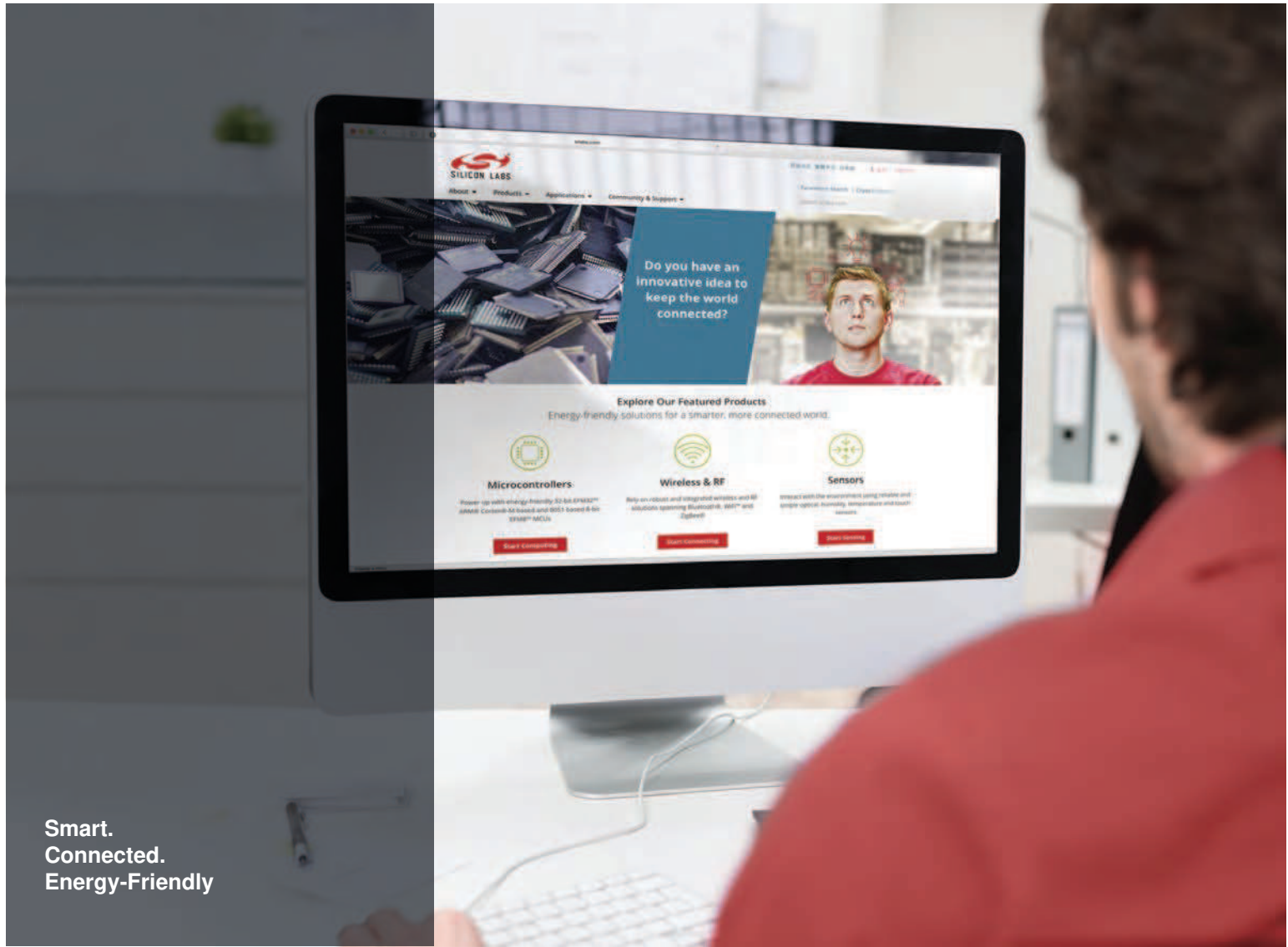

Figure 8. TS1003 Demo Board
Bottom Layer (GND) #2



Smart.
Connected.
Energy-Friendly



Products
www.silabs.com/products

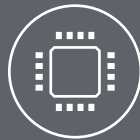

Quality
www.silabs.com/quality



Support and Community
community.silabs.com

Disclaimer

Silicon Laboratories intends to provide customers with the latest, accurate, and in-depth documentation of all peripherals and modules available for system and software implementers using or intending to use the Silicon Laboratories products. Characterization data, available modules and peripherals, memory sizes and memory addresses refer to each specific device, and "Typical" parameters provided can and do vary in different applications. Application examples described herein are for illustrative purposes only. Silicon Laboratories reserves the right to make changes without further notice and limitation to product information, specifications, and descriptions herein, and does not give warranties as to the accuracy or completeness of the included information. Silicon Laboratories shall have no liability for the consequences of use of the information supplied herein. This document does not imply or express copyright licenses granted hereunder to design or fabricate any integrated circuits. The products must not be used within any Life Support System without the specific written consent of Silicon Laboratories. A "Life Support System" is any product or system intended to support or sustain life and/or health, which, if it fails, can be reasonably expected to result in significant personal injury or death. Silicon Laboratories products are generally not intended for military applications. Silicon Laboratories products shall under no circumstances be used in weapons of mass destruction including (but not limited to) nuclear, biological or chemical weapons, or missiles capable of delivering such weapons.

Trademark Information

Silicon Laboratories Inc., Silicon Laboratories, Silicon Labs, SiLabs and the Silicon Labs logo, CMEMS®, EFM, EFM32, EFR, Energy Micro, Energy Micro logo and combinations thereof, "the world's most energy friendly microcontrollers", Ember®, EZLink®, EZMac®, EZRadio®, EZRadioPRO®, DSPLL®, ISOmodem®, Precision32®, ProSLIC®, SiPHY®, USBXpress® and others are trademarks or registered trademarks of Silicon Laboratories Inc. ARM, CORTEX, Cortex-M3 and THUMB are trademarks or registered trademarks of ARM Holdings. Keil is a registered trademark of ARM Limited. All other products or brand names mentioned herein are trademarks of their respective holders.



SILICON LABS

Silicon Laboratories Inc.
400 West Cesar Chavez
Austin, TX 78701
USA

<http://www.silabs.com>