



Chipsmall Limited consists of a professional team with an average of over 10 year of expertise in the distribution of electronic components. Based in Hongkong, we have already established firm and mutual-benefit business relationships with customers from,Europe,America and south Asia,supplying obsolete and hard-to-find components to meet their specific needs.

With the principle of “Quality Parts,Customers Priority,Honest Operation,and Considerate Service”,our business mainly focus on the distribution of electronic components. Line cards we deal with include Microchip,ALPS,ROHM,Xilinx,Pulse,ON,Everlight and Freescale. Main products comprise IC,Modules,Potentiometer,IC Socket,Relay,Connector.Our parts cover such applications as commercial,industrial, and automotives areas.

We are looking forward to setting up business relationship with you and hope to provide you with the best service and solution. Let us make a better world for our industry!



Contact us

Tel: +86-755-8981 8866 Fax: +86-755-8427 6832

Email & Skype: info@chipsmall.com Web: www.chipsmall.com

Address: A1208, Overseas Decoration Building, #122 Zhenhua RD., Futian, Shenzhen, China



SOT-23

Pin Definition:

1. Cathode
2. Reference
3. Anode

General Description

TS1431 series integrated circuits are three-terminal programmable shunt regulator diodes. These monolithic IC voltage references operate as a low temperature coefficient zener which is programmable from V_{REF} to 36 volts with two external resistors. These devices exhibit a wide operating current range of 1.0 to 100mA with a typical dynamic impedance of 0.22Ω. The characteristics of these references make them excellent replacements for zener diodes in many applications such as digital voltmeters, power supplies, and op amp circuitry. The 2.5V reference makes it convenient to obtain a stable reference from 5.0V logic supplies, and since The TS1431 series operates as a shunt regulator, it can be used as either a positive or negative stage reference.

Features

- Precision Reference Voltage
TS1431A – 2.495V±1%
TS1431B – 2.495V±0.5%
- Equivalent Full Range Temp. Coefficient: 50ppm/ °C
- Programmable Output Voltage up to 36V
- Fast Turn-On Response
- Sink Current Capability of 1~100mA
- Low Dynamic Output Impedance: 0.2Ω
- Low Output Noise

Application

- Voltage Monitor
- Delay Timmer
- Constant –Current Source/Sink
- High-Current Shunt Regulator
- Crow Bar
- Over-Voltage / Under-Voltage Protection

Ordering Information

Part No.	Package	Packing
TS1431xCX RFG	SOT-23	3,000pcs / 7" Reel

Note: "G" denote for Green Product
Where **xx** denotes voltage tolerance
A: ±1%, **B:** ±0.5%

Block Diagram

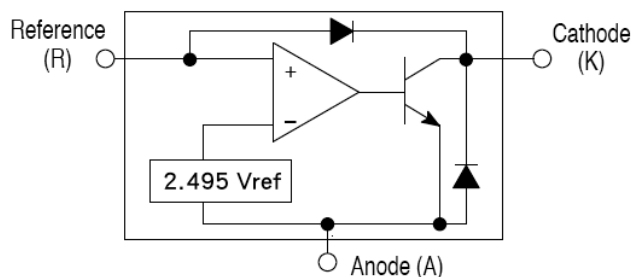

Absolute Maximum Ratings ($T_A = 25^\circ\text{C}$ unless otherwise noted)

Parameter	Symbol	Limit	Unit
Cathode Voltage	V_{KA}	36	V
Continuous Cathode Current Range	I_{KA}	1 ~ +100	mA
Reference Input Current Range	I_{REF}	-0.05 ~ +10	mA
Power Dissipation	P_D	0.30	W
Junction Temperature	T_J	+150	°C
Operating Temperature Range	T_{OPR}	0 ~ +70	°C
Storage Temperature Range	T_{STG}	-65 ~ +150	°C

Recommended Operating Condition

Parameter	Symbol	Limit	Unit
Cathode Voltage ^(Note 1)	V_{KA}	Ref ~ 36	V
Continuous Cathode Current Range	I_K	1 ~ 100	mA

Electrical Characteristics

Parameter	Symbol	Test Conditions	Min	Typ	Max	Unit
Reference voltage	V_{REF}	$V_{KA} = V_{REF}, I_K = 10mA$ (Figure 1) $T_A = 25^\circ C$	2.475	2.495	2.525	V
			2.487		2.513	
Deviation of reference input voltage	ΔV_{REF}	$V_{KA} = V_{REF}, I_K = 10mA$ (Figure 1) $T_A = \text{full range}$	--	3	17	mV
Radio of change in Vref to change in cathode Voltage	$\Delta V_{REF} / \Delta V_{KA}$	$I_{KA} = 10mA, V_{KA} = 10V \text{ to } V_{REF}$ $V_{KA} = 36V \text{ to } 10V$ (Figure 2)	--	-1.4 -1.0	-2.7 -2.0	mV/V
Reference Input current	I_{REF}	$R1 = 10K\Omega, R2 = \infty, I_{KA} = 10mA$ $T_A = \text{full range}$ (Figure 2)	--	0.7	4.0	μA
Deviation of reference input current, over temp.	ΔI_{REF}	$R1 = 10K\Omega, R2 = \infty, I_{KA} = 10mA$ $T_A = \text{full range}$ (Figure 2)	--	0.4	1.2	μA
Off-state Cathode Current	$I_{KA} \text{ (off)}$	$V_{REF} = 0V$ (Figure 3), $V_{KA} = 36V$	--	--	1.0	μA
Dynamic Output Impedance	$ Z_{KA} $	$f < 1KHz, V_{KA} = V_{REF}$ $I_{KA} = 1mA \text{ to } 100mA$ (Figure 1)	--	0.22	0.5	Ω
Minimum operating cathode current	$I_{KA} \text{ (min)}$	$V_{KA} = V_{REF}$ (Figure 1)	--	0.4	0.6	mA

* The deviation parameters ΔV_{REF} and ΔI_{REF} are defined as difference between the maximum value and minimum value obtained over the full operating ambient temperature range that applied.

* The average temperature coefficient of the reference input voltage, αV_{REF} is defined as:

$$\alpha V_{ref} \left(\frac{\text{ppm}}{^\circ C} \right) = \frac{\left(\frac{\Delta V_{ref}}{V_{ref} (T_A = 25^\circ C)} \times 10^6 \right)}{\Delta T_A}$$

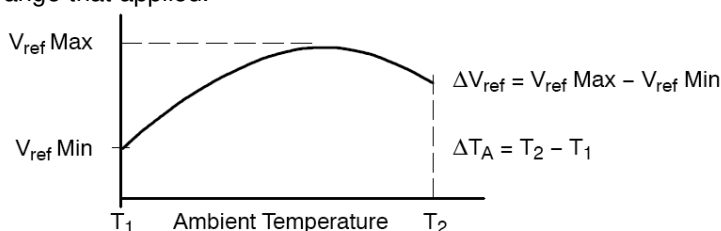

Where: $T_2 - T_1$ = full temperature change.

αV_{REF} can be positive or negative depending on whether the slope is positive or negative.

Example: Maximum $V_{REF} = 2.496V$ at $30^\circ C$, minimum $V_{REF} = 2.492V$ at $0^\circ C$, $V_{REF} = 2.495V$ at $25^\circ C$, $\Delta T = 70^\circ C$

$$\alpha V_{REF} = [4mV / 2495mV] * 10^6 / 70^\circ C \approx 23ppm/^\circ C$$

Because minimum V_{REF} occurs at the lower temperature, the coefficient is positive.

* The dynamic impedance Z_{KA} is defined as:

$$|Z_{KA}| = \Delta V_{KA} / \Delta I_{KA}$$

* When the device operating with two external resistors, $R1$ and $R2$, (refer to Figure 2) the total dynamic impedance of the circuit is given by:

$$|Z_{KA}| = \Delta v / \Delta i \approx Z_{KA} * (1 + R1 / R2)$$

Test Circuits

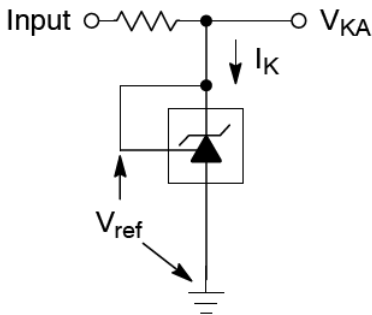

Figure 1: $V_{KA} = V_{REF}$

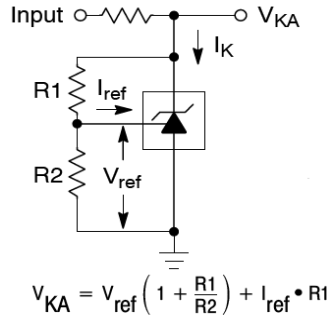

Figure 2: $V_{KA} > V_{REF}$

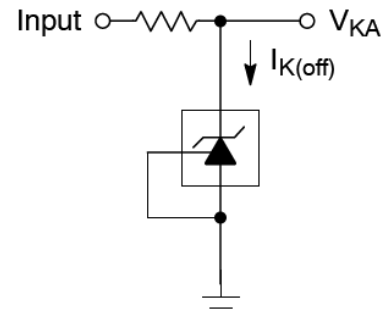

Figure 3: Off-State Current

Additional Information – Stability

When The TS1431A/1431B is used as a shunt regulator, there are two options for selection of C_L , are recommended for optional stability:

- A) No load capacitance across the device, decouple at the load.
- B) Large capacitance across the device, optional decoupling at the load.

The reason for this is that TS1431A/1431B exhibits instability with capacitances in the range of 10nF to 1 μ F (approx.) at light cathode current up to 3mA(typ). The device is less stable the lower the cathode voltage has been set for. Therefore while the device will be perfectly stable operating at a cathode current of 10mA (approx.) with a 0.1 μ F capacitor across it, it will oscillate transiently during start up as the cathode current passes through the instability region. Select a very low capacitance, or alternatively a high capacitance (10 μ F) will avoid this issue altogether. Since the user will probably wish to have local decoupling at the load anyway, the most cost effective method is to use no capacitance at all directly across the device. PCB trace/via resistance and inductance prevent the local load decoupling from causing the oscillation during the transient start up phase.

Note: if the TS1431A/1431B is located right at the load, so the load decoupling capacitor is directly across it, then this capacitor will have to be ≤ 1 nF or ≥ 10 μ F.

Applications Examples

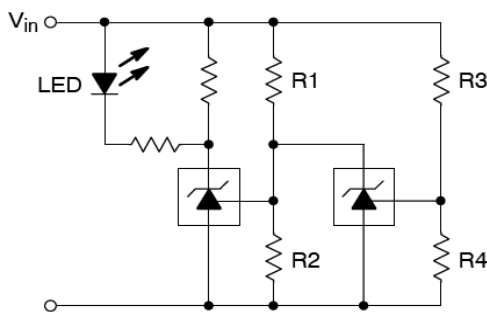

L.E.D. indicator is 'ON' when V_{in} is between the upper and lower limits,

$$\text{Lower limit} = \left(1 + \frac{R1}{R2}\right) V_{ref}$$

$$\text{Upper limit} = \left(1 + \frac{R3}{R4}\right) V_{ref}$$

Figure 4: Voltage Monitor

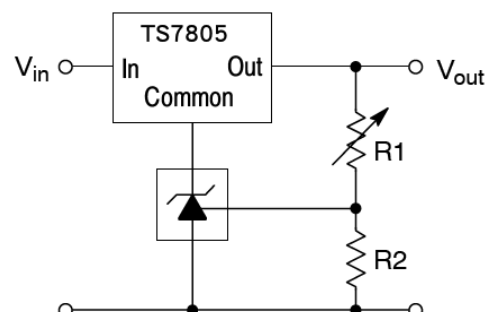

$$V_{out} = \left(1 + \frac{R1}{R2}\right) V_{ref}$$

$$V_{out(min)} = V_{ref} + 5.0 \text{ V}$$

Figure 5: Output Control for Three Terminal Fixed Regulator

Applications Examples (Continue)

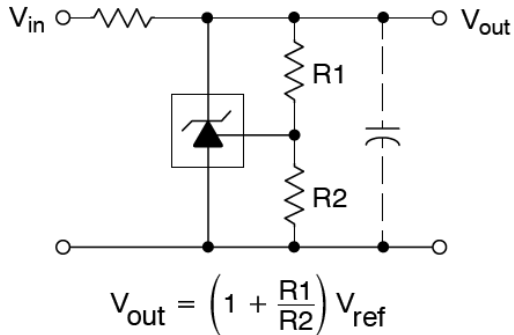

Figure 6: Shunt Regulator

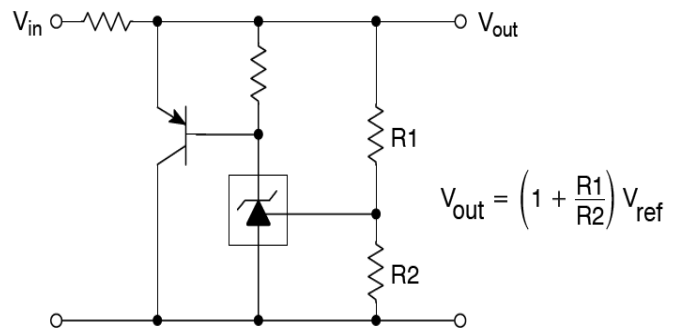

Figure 7: High Current Shunt Regulator

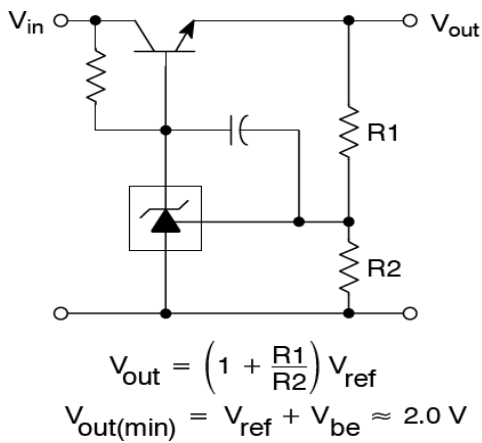

Figure 8: Series Pass Regulator

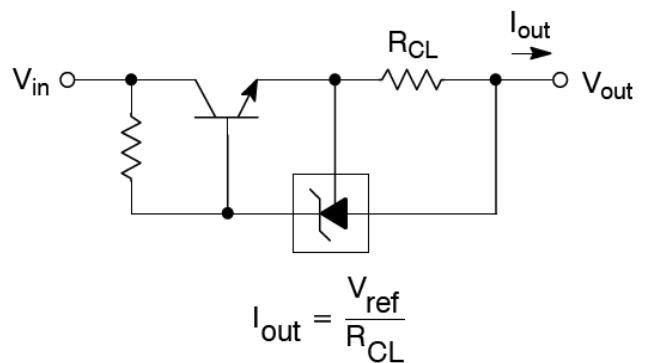

Figure 9: Constant Current Source

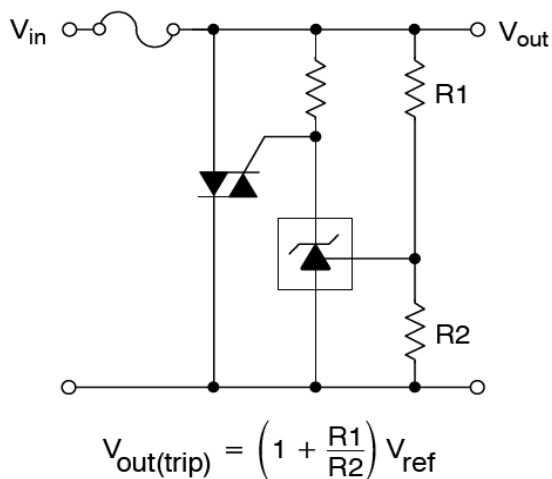

Figure 10: TRIAC Crowbar

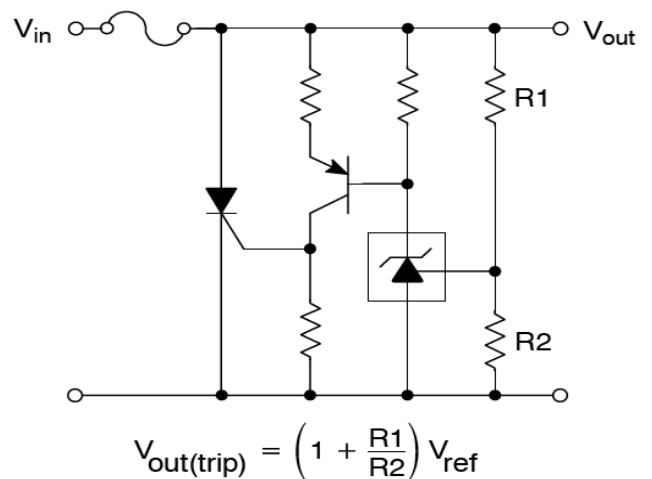
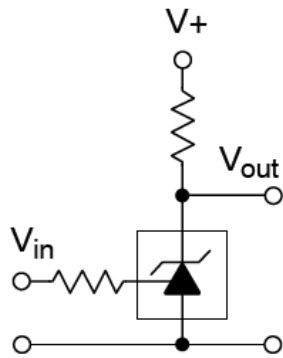

Figure 11: SCR Crowbar

Applications Examples (Continue)



Vin	Vout
<Vref	V+
>Vref	≈0.74V

Figure 12: Single-Supply Comparator with Temperature-Compensated Threshold

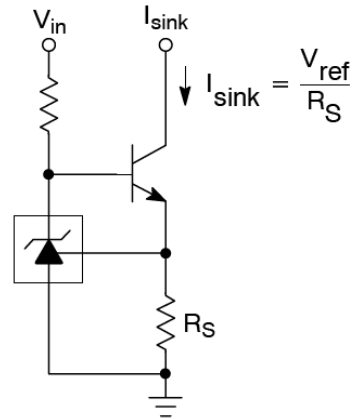

Figure 13: Constant Current Sink

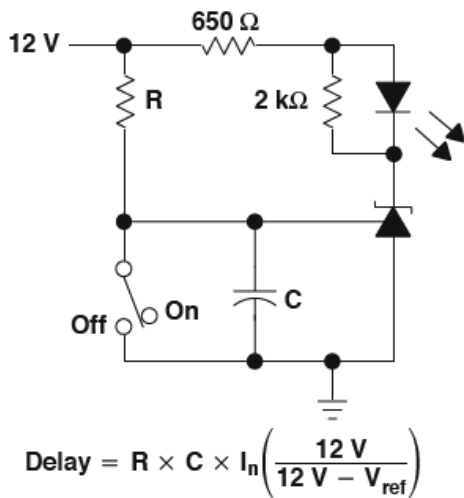

Figure 14: Delay Timer

Typical Performance Characteristics

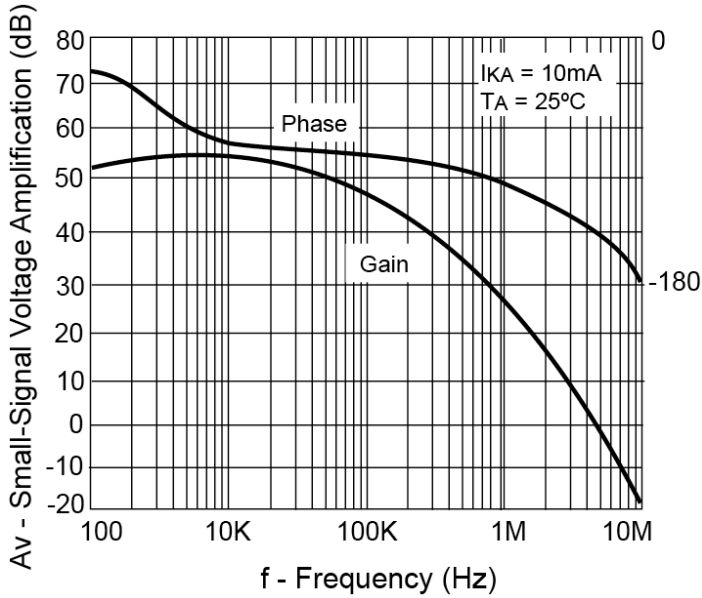
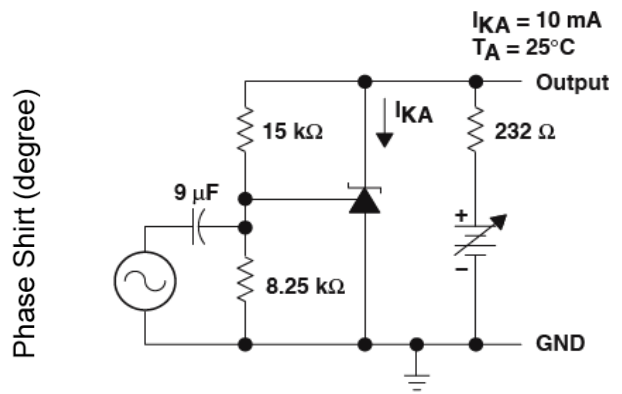

Figure 15: Small-Signal Voltage Gain and Phase Shift vs. Frequency



Test Circuit for Voltage Amplification

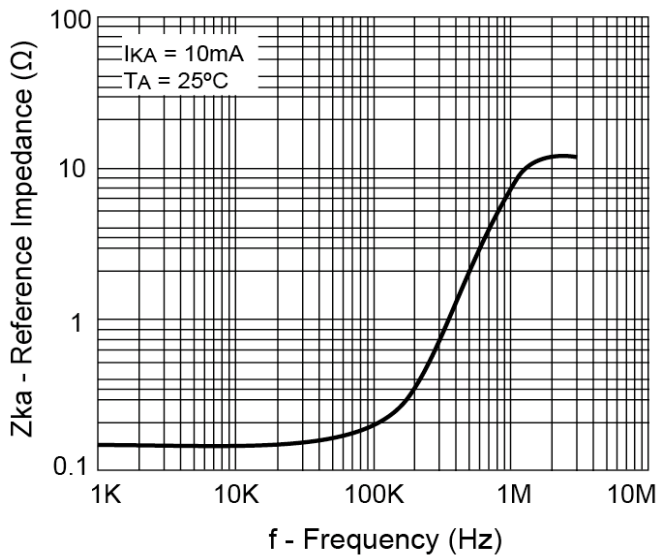
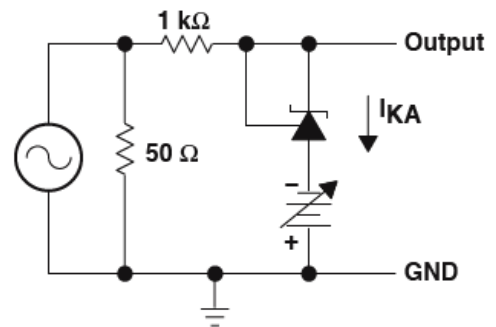
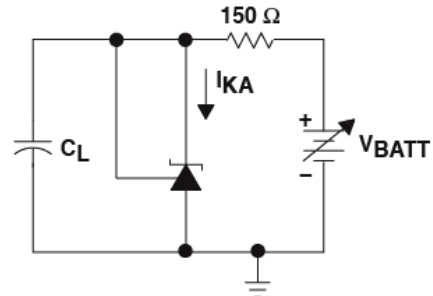
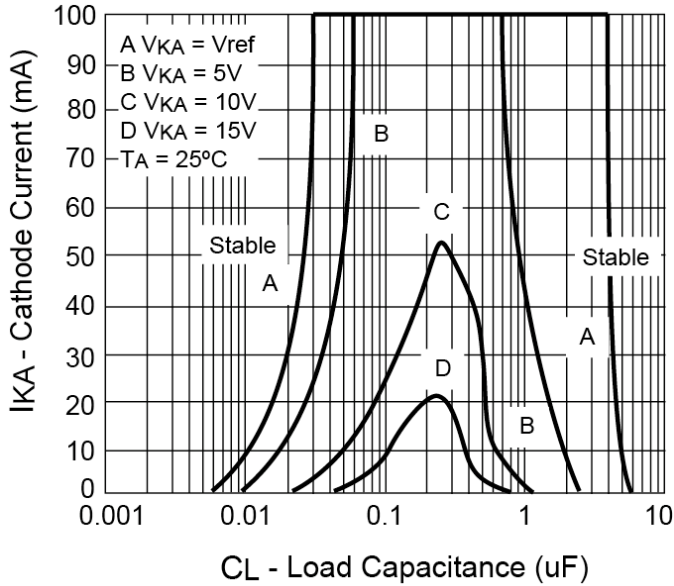

Figure 16: Reference Impedance vs. Frequency



Test Circuit for Reference Impedance

Typical Performance Characteristics (Continue)



Test Circuit for Curve A

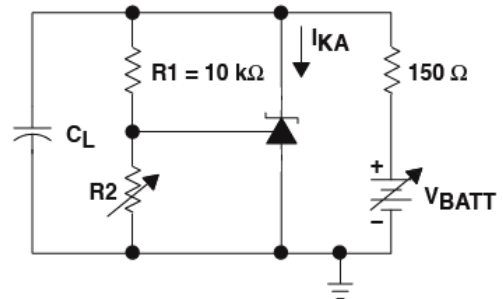

Test Circuit for Curve B, C and D

The areas under the curves represent conditions that may cause the device to oscillate. For curves B, C, and D, R_2 and V_+ were adjusted to establish the initial V_{KA} and I_{KA} conditions with $C_L=0$. V_{BATT} and C_L then were adjusted to determine the ranges of stability.

Figure 17: Stability Boundary Condition

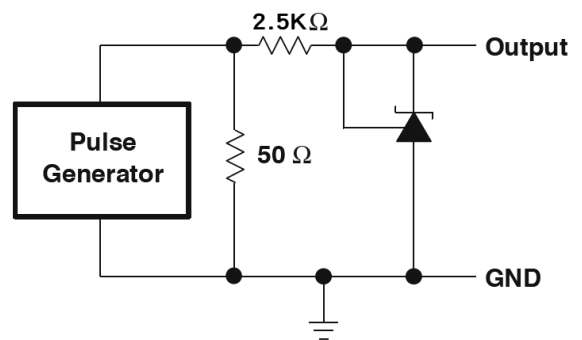
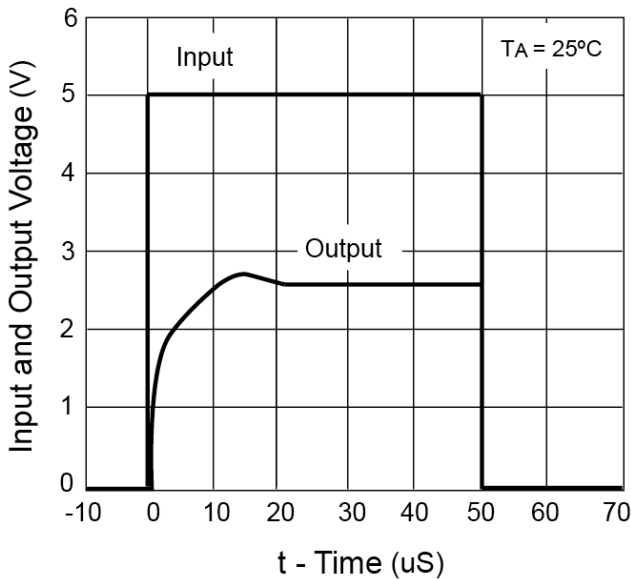

Test Circuit for Pulse Response, $I_{k=1mA}$

Figure 18: Pulse Response

Electrical Characteristics

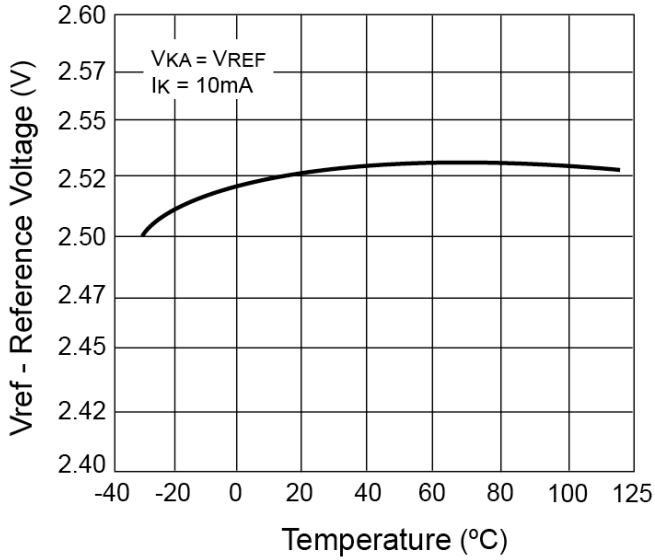

Figure 19: Reference Voltage vs. Temperature

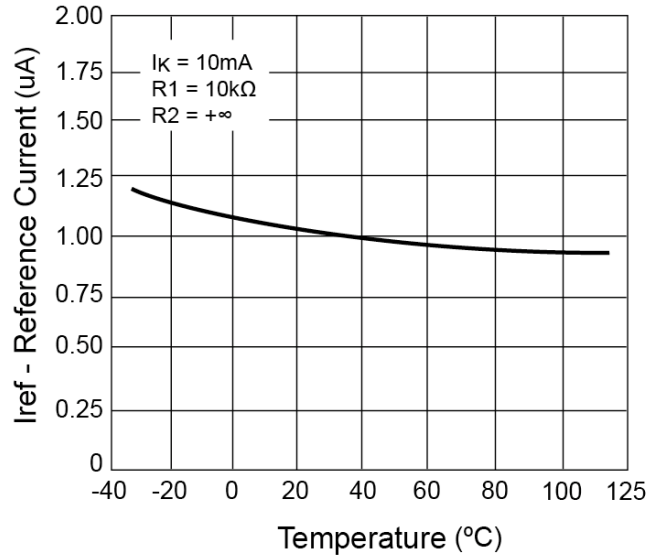

Figure 20: Reference Current vs. Temperature

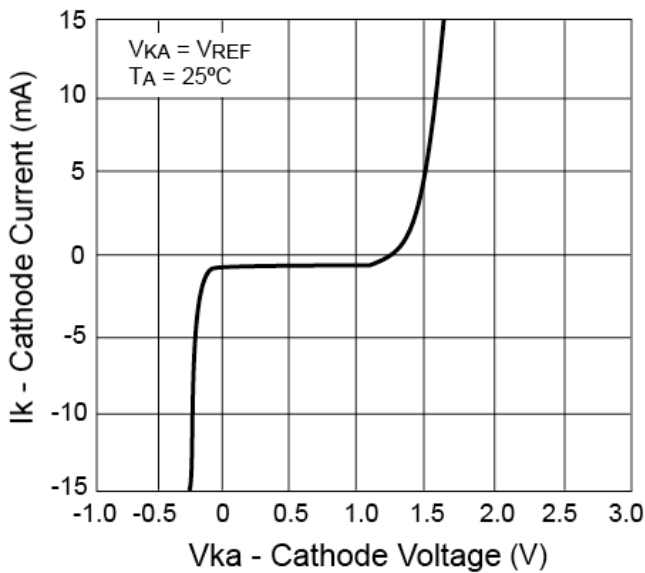
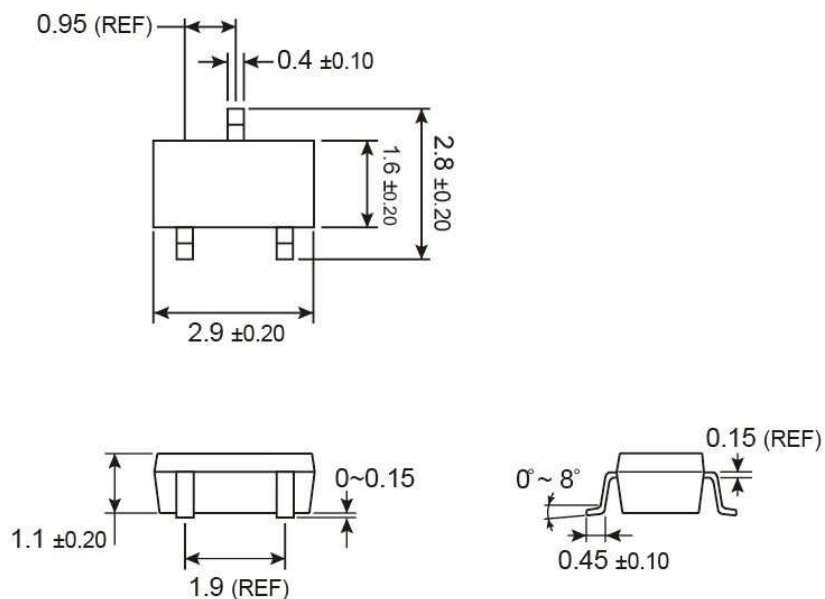

Figure 21: Cathode Current vs. Cathode Voltage

SOT-23 Mechanical Drawing



Unit: Millimeters

Marking Diagram

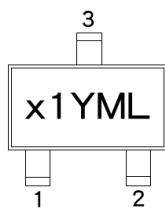

- x** = Tolerance Code
(**A** = $\pm 1\%$, **B** = $\pm 0.5\%$)
- 1** = Device Code
- Y** = Year Code
- M** = Month Code for Halogen Free Product

O =Jan	P =Feb	Q =Mar	R =Apr
S =May	T =Jun	U =Jul	V =Aug
W =Sep	X =Oct	Y =Nov	Z =Dec
- L** = Lot Code

Notice

Specifications of the products displayed herein are subject to change without notice. TSC or anyone on its behalf, assumes no responsibility or liability for any errors or inaccuracies.

Information contained herein is intended to provide a product description only. No license, express or implied, to any intellectual property rights is granted by this document. Except as provided in TSC's terms and conditions of sale for such products, TSC assumes no liability whatsoever, and disclaims any express or implied warranty, relating to sale and/or use of TSC products including liability or warranties relating to fitness for a particular purpose, merchantability, or infringement of any patent, copyright, or other intellectual property right.

The products shown herein are not designed for use in medical, life-saving, or life-sustaining applications. Customers using or selling these products for use in such applications do so at their own risk and agree to fully indemnify TSC for any damages resulting from such improper use or sale.