



Chipsmall Limited consists of a professional team with an average of over 10 year of expertise in the distribution of electronic components. Based in Hongkong, we have already established firm and mutual-benefit business relationships with customers from,Europe,America and south Asia,supplying obsolete and hard-to-find components to meet their specific needs.

With the principle of “Quality Parts,Customers Priority,Honest Operation,and Considerate Service”,our business mainly focus on the distribution of electronic components. Line cards we deal with include Microchip,ALPS,ROHM,Xilinx,Pulse,ON,Everlight and Freescale. Main products comprise IC,Modules,Potentiometer,IC Socket,Relay,Connector.Our parts cover such applications as commercial,industrial, and automotives areas.

We are looking forward to setting up business relationship with you and hope to provide you with the best service and solution. Let us make a better world for our industry!



## Contact us

Tel: +86-755-8981 8866 Fax: +86-755-8427 6832

Email & Skype: info@chipsmall.com Web: www.chipsmall.com

Address: A1208, Overseas Decoration Building, #122 Zhenhua RD., Futian, Shenzhen, China



## AC/DC WLED Driver with Average-Mode Constant Current Control

### DESCRIPTION

The TS19460 is an average current mode control LED driver IC operating in a constant off-time mode. It greatly improves accuracy, line and load regulation of the LED current without any need for loop compensation or high-side current sensing. The output LED current accuracy is at  $\pm 5\%$ , and it is equipped with current limit comparator for hiccup mode output short circuit protection.

The TS19460 can be powered from an 8V~450V supply. A PWM dimming input is provided that accepts an external control TTL compatible signal. The output current can be programmed by an internal 250mV reference, or controlled externally through a 0~1.5V dimming input. The TS19460 is ideally suited for buck LED drivers and is requires only free external components (apart from the power stage) to produce a controlled LED current making it an ideal solution for low cost LED drivers.

### FEATURES

- Fast average current controller
- Programmable constant off-time switching
- Linear and PWM dimming capability
- Requires few external components for operation
- Output short circuit protection with skip mode
- Pin –compatible with TS19450CS

### APPLICATION

- DC/DC or AC/DC LED driver applications
- RGB backlighting LED driver
- Back lighting of flat panel displays
- General purpose constant current source
- Signage and decorative LED lighting
- LED street lighting



#### Pin Definition:

- |             |             |
|-------------|-------------|
| 1. $V_{IN}$ | 8. $R_T$    |
| 2. CS       | 7. LD       |
| 3. GND      | 6. $V_{DD}$ |
| 4. Gate     | 5. PWMD     |

**Notes:** Moisture sensitivity level: level 3. Per J-STD-020

### TYPICAL APPLICATION CIRCUIT

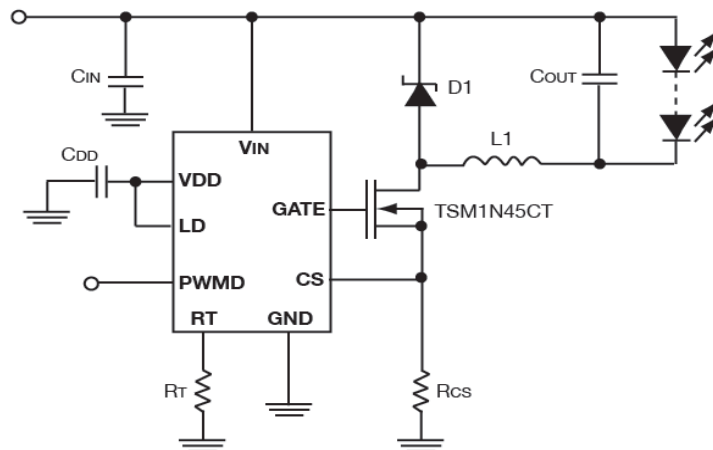

<b>ABSOLUTE MAXIMUM RATINGS</b> ( $T_A = 25^\circ\text{C}$ unless otherwise specified) <sup>(Note 1)</sup>			
PARAMETER	SYMBOL	LIMIT	UNIT
Input Voltage Range	$V_{IN}$ to GND	-0.5 ~ +470	V
Internal Regulated Voltage	$V_{DD}$ to GND	12	V
CS, LD, PWMD, Gate, RT to GND		-0.3 ~ ( $V_{DD}+0.3$ )	V
Continuous Power Dissipation <sup>(Note 2)</sup>	$P_D$	650	mW
Storage Temperature Range	$T_A$	-65 to +150	$^\circ\text{C}$
Junction Temperature Range	$T_J$	-40 to +150	$^\circ\text{C}$

<b>THERMAL PERFORMANCE</b> <sup>(Note 3)</sup>			
PARAMETER	SYMBOL	LIMIT	UNIT
Thermal Resistance – Junction to Ambient	$R_{\theta JA}$	128	$^\circ\text{C/W}$

<b>ELECTRICAL SPECIFICATIONS</b> ( $T_A = 25^\circ\text{C}$ , $V_{IN} = 12\text{V}$ , $V_{LD} = \text{PWM} = V_{DD}$ , unless otherwise noted) <sup>(Note 4)</sup>						
PARAMETER	SYMBOL	CONDITION	MIN	TYP	MAX	UNIT
<b>Input</b>						
DC Input Voltage Range	$V_{INDC}$	DC input voltage	8.0	--	450	V
Shut-down Mode Supply Current	$I_{INSD}$	Pin PWMD to GND	--	0.5	1.0	mA
<b>Internal Regulator</b>						
Internally Regulated Voltage	$V_{DD}$	$V_{IN} = 8\text{V}$ , $I_{DD(EXT)} = 0$ , 500pF at Gate, $R_T = 226\text{k}\Omega$	7.25	7.5	7.75	V
Line Regulation of $V_{DD}$	$\Delta V_{DDLine}$	$V_{IN} = 8 \sim 450\text{V}$ , $I_{DD(EXT)} = 0$ 500pF at Gate, $R_T = 226\text{k}\Omega$	0	--	1.0	V
Load Regulation of $V_{DD}$	$\Delta V_{DDLload}$	$I_{DD(EXT)} = 0 \sim 1\text{mA}$ 500pF at Gate, $R_T = 226\text{k}\Omega$	0	--	100	mV
Undervoltage Lockout Threshold	UVLO	$V_{IN}$ rising	6.45	6.7	6.95	V
Undervoltage Lockout Hysteresis	$\Delta UVLO$	$V_{IN}$ falling	--	500	--	mV
Maximum Input Current	$I_{IN(MAX)}$	$V_{IN} = 8\text{V}$	3.5	--	--	mA
<b>Dimming</b>						
PWMD Input Low Voltage	$V_{ENL}$	$V_{IN} = 8\text{V} \sim 450\text{V}$	--	--	0.8	V
PWMD Input High Voltage	$V_{ENH}$	$V_{IN} = 8\text{V} \sim 450\text{V}$	2.0	--	--	V
PWMD Pull-down resistance at PWMD	$R_{EN}$	$V_{PWMD} = 5\text{V}$	50	100	150	$\text{k}\Omega$

<b>ELECTRICAL SPECIFICATIONS</b> ( $T_A = 25^\circ\text{C}$ , $V_{IN} = 12\text{V}$ , $V_{LD} = \text{PWM} = V_{DD}$ , unless otherwise noted)						
PARAMETER	SYMBOL	CONDITION	MIN	TYP	MAX	UNIT
<b>Average Current Sense Logic</b>						
Current Sense Reference Voltage	$V_{CS}$		238	250	262	mV
LD to Current Sense Ratio	$A_{V(LD)}$		--	0.18	--	mV
LD input Voltage Shutdown	$V_{LD(OFF)}$	$V_{LD}$ falling	--	150	--	mV
LD input Voltage Enable	$\Delta V_{LD(OFF)}$	$V_{LD}$ rising	--	200	--	mV
Current Sense Blanking Interval	$T_{BLANK}$		150	--	280	ns
Minimum On-Time	$T_{ON(min)}$	$V_{CS} = V_{CS} + 30\text{mV}$	--	--	1	$\mu\text{S}$
Off Time	$T_{OFF}$	$R_T = 1\text{M}\Omega$	32	--	48	$\mu\text{S}$
		$R_T = 226\text{k}\Omega$	8	--	12	
Max. Steady-State Duty Cycle	$D_{MAX}$		75	--	--	%
<b>Short Circuit Protection</b>						
Hiccup Threshold Voltage	$V_{CS}$		410	--	470	mV
Current Limit Delay CS to Gate	$T_{DELAY}$	$V_{CS} = V_{CS} + 30\text{mV}$	--	--	150	ns
Short Circuit Hiccup Time	$T_{HICCUP}$		330	--	460	$\mu\text{S}$
Minimum On-Time (Short Circuit)	$T_{ON(min)}$	$V_{CS} = V_{DD}$	--	--	430	$\mu\text{S}$
<b>Gate Driver</b>						
Gate Sourcing Current	$I_{SOURCE}$	$V_{GATE} = 0\text{V}$ , $V_{DD} = 7.5\text{V}$	165	--	--	mA
Gate Sinking Current	$I_{SINK}$	$V_{GATE} = V_{DD}$ , $V_{DD} = 7.5\text{V}$	165	--	--	mA
Gate Output Rise Time	$T_{RISE}$	$C_{GATE} = 500\text{pF}$ , $V_{DD} = 7.5\text{V}$	--	30	50	ns
Gate Output Fall Time	$T_{FALL}$	$C_{GATE} = 500\text{pF}$ , $V_{DD} = 7.5\text{V}$	--	30	50	ns

**Note:**

1. Stresses listed as the above "Absolute Maximum Ratings" may cause permanent damage to the device. These are for stress ratings. Functional operation of the device at these or any other conditions beyond those indicated in the operational sections of the specifications is not implied. Exposure to absolute maximum rating conditions for extended periods may remain possibility to affect device reliability.
2. Limited by package power dissipation, whichever is lower.
3. Thermal Resistance is specified with the component mounted on a low effective thermal conductivity test board in free air at  $T_A = 25^\circ\text{C}$ .
4. Denotes the specifications which apply over the full operating ambient temperature range of  $-40^\circ\text{C} < T_A < +125^\circ\text{C}$ .

**ORDERING INFORMATION**

<b>PART NO.</b>	<b>PACKAGE</b>	<b>PACKING</b>
TS19460CS RLG	SOP-8	2,500pcs / 13" Reel

**Note:**

1. Compliant to RoHS Directive 2011/65/EU and in accordance to WEEE 2002/96/EC.
2. Halogen-free according to IEC 61249-2-21 definition.

**FUNCTION BLOCK DIAGRAM**

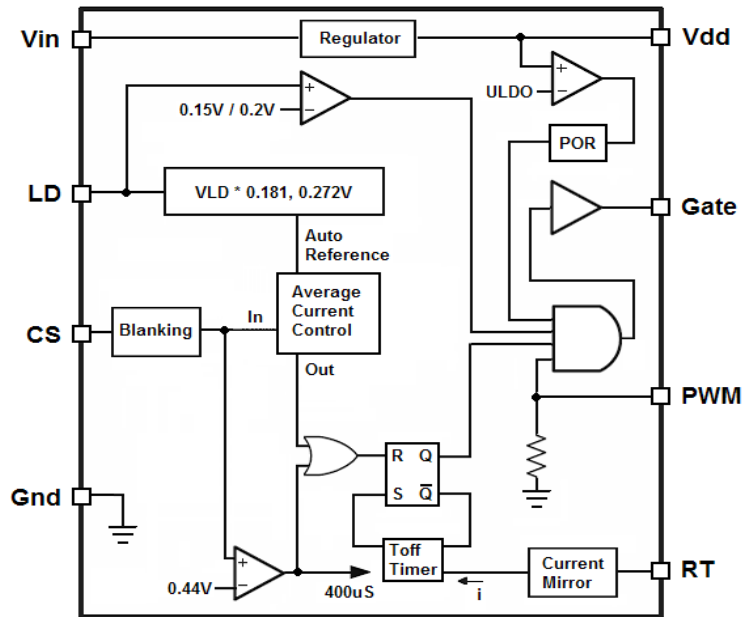

**PIN DESCRIPTION**

PIN NO.	NAME	FUNCTION
1	VIN	This pin is the input of 8V~450V linear regulator
2	CS	This pin is the current sense pin used to sense the MOSFET current by means of an external sense resistor.
3	GND	Ground return for all internal circuitry. This pin must be electrically connected to the ground of the power train.
4	GATE	This pin is the output GATE driver for an external N-CH Power MOSFET
5	PWMD	This is the PWM dimming input of the IC. When this pin is pulled to GND, the Gate Driver is turned off. When the pin is pulled high, the GATE driver operates normally.
6	VDD	This is the power supply pin for all internal circuits. It must be bypassed with a low ESR capacitor to GND ( $\geq 0.1\mu\text{F}$ )
7	LD	This pin is the linear dimming input and sets the current sense threshold as long as the voltage at the pin is less than 1.5V, The Gate output is disable when LD voltage $< 150\text{mV}$ (typ.) and recovery when LD voltage $> 200\text{mV}$ (typ.)
8	RT	A resistor is connected between RT and GND to program the Gate off-time.

## APPLICATION INFORMATION

The TS19460 is optimized to drive buck LED drivers using average current mode control. This method of control enables fairly accurate LED current control without the need for high side current sensing or the design of any closed loop controllers. The IC uses very few external components and enables both linear and PWM dimming of the LED current.

A resistor connected to the RT pin programs the off-time. Constant off-time control average current mode is used for stability and to improve the LED current regulation over a wide range of input voltages.

The current through the switching MOSFET source is averaged and used to give constant-current feedback. This current is detected from a sense resistor at the CS pin, the feedback operates in a fast open-loop mode, there is no compensation required, the output current is programmed as

$$I_{LED} = 0.25V / R_{CS}$$

When the Voltage at the LD input >1.5V, otherwise

$$I_{LED} = ( V_{LD} * 0.181 ) / R_{CS}$$

When application to design the inductor witching ripple current in it is 40% of average peak to peak, full load current, the inductance can be calculated as follow:

$$L_{OUT} = ( V_{OUT(max)} * T_{OFF} ) / ( 0.4 * I_{OUT} )$$

The duty cycle range of current control feedback is limited to duty <75%, A reduction in the LED current string voltage is greater than 75% of input voltage.

Reducing the output LED voltage is below  $V_{OUT(MIN)} = V_{IN} * D_{(MIN)}$ , where  $D_{(MIN)} = 1\mu S / (T_{OFF} + 1\mu S)$ , may also result in the loss of regulation of LED current. This condition will cause an increase in the LED current and can be possible to trip the short circuit protection comparator.

The short circuit protection comparator trips when the voltage at CS exceeds 0.44V, the Gate off time ( $T_{HICCUP} = 400\mu s$ ) is generated to prevent stair-casing of inductor current and potentially its saturation due to insufficient output voltage.

The leading edge blanking delay is provided at CS to prevent false triggering of current feedback and short circuit protection.

### Input Voltage Regulator

The TS19460 can be powered directly from its  $V_{IN}$  pin and can work from  $8.0V_{DC} \sim 450V_{DC}$  at its  $V_{IN}$  pin. When a voltage is applied at the  $V_{IN}$  pin, the TS19460 maintains a constant 7.5V at the  $V_{DD}$  pin. This voltage is used to power the IC and any external resistor dividers needed to control the IC. The  $V_{DD}$  pin must be bypassed by a low ESR capacitor to provide a low impedance path for the high frequency current of the output GATE driver. The TS19460 can be also operated by supplying a voltage at the  $V_{DD}$  pin greater than the internally regulated voltage. Please note that this external voltage at the  $V_{DD}$  pin should not exceed 12V.

Although the  $V_{IN}$  pin of the TS19460 is rated up to 450V, the actual maximum voltage that can be applied is limited by the power dissipation in the IC. For example, if an SOP-8 (junction to ambient thermal resistance  $R\theta_{JA} = 128^{\circ}C/W$ ) TS19460 draws about  $I_{IN} = 2.0mA$  from the  $V_{IN}$  pin, and has a maximum allowable temperature rise of the junction temperature limited to about the maximum voltage at the  $V_{IN}$  pin would be:

$$V_{IN(MAX)} = ( T_{J(MAX)} - T_A ) / ( R\theta_{JA} * I_{IN} ) = 390V$$

## APPLICATION INFORMATION (CONTINUE)

In these cases, to operate the TS19460 from higher input voltages, a Zener diode can be added in series with the VIN pin to divert some of the power loss from the TS19460 to the Zener diode. In the above example, using a 100V Zener diode will allow the circuit to easily work up to 490V.

The input current drawn from the VIN pin is a sum of the 1.0mA current drawn by the internal circuit and the current drawn by the GATE driver (which in turn depends on the switching frequency and the GATE charge of the external).

$$I_{IN} \approx 1\text{mA} + Q_G \times f_S$$

In the above equation,  $f_S$  is the switching frequency and  $Q_G$  is the GATE charge of the external MOSFET (which can be obtained from the datasheet of the MOSFET).

### Oscillator

The oscillator in the TS19460 is controlled by a single resistor connected at the RT pin. The equation governing the off-time of the GATE output is given by:

$$T_{OFF(\mu\text{s})} = ( R_T (\text{k}\Omega) / 25 ) + 0.3$$

\*within the range of  $30\text{k}\Omega \leq R_T \leq 1\text{M}\Omega$

### Linear Dimming

The Linear Dimming pin is used to control the LED current, when voltage at LD is fall below 1.5V, the internal reference voltage (250mV) to the constant current feedback become over ridden by  $V_{LD} * 0.181$ , and the current in the inductor remain continuous, the LED current is given by  $I_{LED} = ( V_{LD} * 0.181 ) / R_{CS}$ , The Gate output is disable when LD voltage <150mV(typ.) and recovery when LD voltage >200mV (typ.)

The Linear Dimming input could also be used for mixed-mode dimming to expand the dimming ratio, in this kind of application condition, the pulse-width modulated signal of a measured amplitude below 1.5V should be applied at LD.

### PWM Dimming

PWM Dimming can be achieved by driving the PWMD pin with a square wave signal. The rising and falling edges are limited by current slew rate in inductor, the first switching cycle is terminated upon reaching the level (250mV) at CS, the circuit is further reaching its steady state within 3~5 switching cycle regardless of the switching frequency.



**PACKAGE OUTLINE DIMENSIONS** (Unit: Millimeters)

**SOP-8**

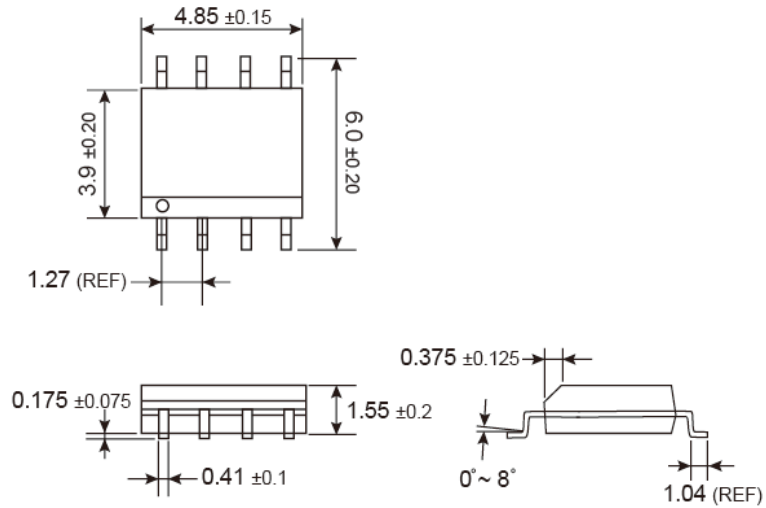

**SUGGESTED PAD LAYOUT** (Unit: Millimeters)

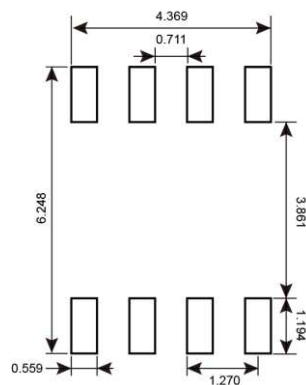

**Marking Diagram**

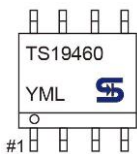

- Y** = Year Code
- M** = Month Code for Halogen Free Product
  - O** =Jan    **P** =Feb    **Q** =Mar    **R** =Apr
  - S** =May    **T** =Jun    **U** =Jul    **V** =Aug
  - W** =Sep    **X** =Oct    **Y** =Nov    **Z** =Dec
- L** = Lot Code (1~9, A~Z)

## Notice

Specifications of the products displayed herein are subject to change without notice. TSC or anyone on its behalf, assumes no responsibility or liability for any errors or inaccuracies.

Information contained herein is intended to provide a product description only. No license, express or implied, to any intellectual property rights is granted by this document. Except as provided in TSC's terms and conditions of sale for such products, TSC assumes no liability whatsoever, and disclaims any express or implied warranty, relating to sale and/or use of TSC products including liability or warranties relating to fitness for a particular purpose, merchantability, or infringement of any patent, copyright, or other intellectual property right.

The products shown herein are not designed for use in medical, life-saving, or life-sustaining applications. Customers using or selling these products for use in such applications do so at their own risk and agree to fully indemnify TSC for any damages resulting from such improper use or sale.