



Chipsmall Limited consists of a professional team with an average of over 10 year of expertise in the distribution of electronic components. Based in Hongkong, we have already established firm and mutual-benefit business relationships with customers from,Europe,America and south Asia,supplying obsolete and hard-to-find components to meet their specific needs.

With the principle of “Quality Parts,Customers Priority,Honest Operation,and Considerate Service”,our business mainly focus on the distribution of electronic components. Line cards we deal with include Microchip,ALPS,ROHM,Xilinx,Pulse,ON,Everlight and Freescale. Main products comprise IC,Modules,Potentiometer,IC Socket,Relay,Connector.Our parts cover such applications as commercial,industrial, and automotives areas.

We are looking forward to setting up business relationship with you and hope to provide you with the best service and solution. Let us make a better world for our industry!



## Contact us

Tel: +86-755-8981 8866 Fax: +86-755-8427 6832

Email & Skype: info@chipsmall.com Web: www.chipsmall.com

Address: A1208, Overseas Decoration Building, #122 Zhenhua RD., Futian, Shenzhen, China



### TRIUNE PRODUCTS

---

#### Features

- Wide input supply operating range
  - ♦ TS31023 : 5V-16V
  - ♦ TS31223 : 5V-36V
- Adjustable output voltage from 1.25V to  $V_{IN} - V_{dropout}$
- 60mA output current capability
- Enable control function

#### Applications

- Set-top Boxes
- Automotive
- Industrial
- Medical
- Energy harvesting systems
- Wireless Power

#### Description

The TS31x23 high voltage linear regulator consists of a low power amplifier with a high voltage p-channel pass gate.

The linear regulator has a wide operating range, and is ideal for systems that may have large voltage transients and require the output load to remain regulated.

An analog current limit is used to limit output current and protect the regulator from external short circuits.

#### Summary Specification

- Packaged in a 8pin DFN (2x2)

### Typical Application Circuit

---

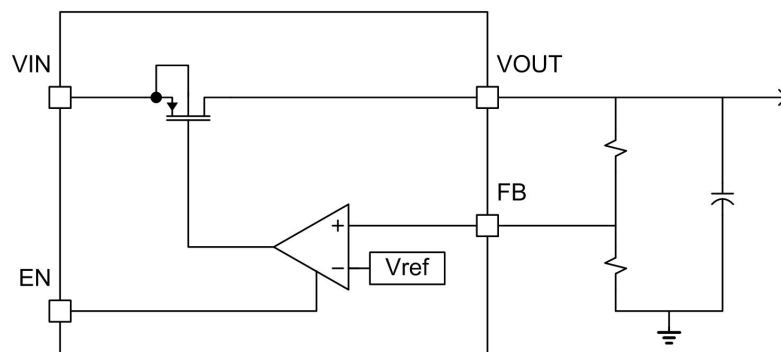

## Pin-out Configuration

Pin #	Pin Symbol	I/O/P	Description
1	GND	P	Ground
2	VOUT	O	Regulated Output Voltage
3	N/C		No Connect
4	N/C		No Connect
5	N/C		No Connect
6	FB	I	Feedback Voltage
7	VIN	P	Input Voltage
8	EN	I	ENABLE Input

## Absolute Maximum Ratings

Over operating free-air temperature range unless otherwise noted(1,2)

		Unit
VIN	-0.3 to 18 (TS31023) -0.3 to 40 (TS31223)	V
VOUT	-0.3 to 18 (TS31023) -0.3 to 40 (TS31223)	V
EN, FB	-0.3 to 6.0	V
Electrostatic Discharge – Human Body Model	2	kV
Maximum junction temperature, TJ	150	°C
Storage temperature range, Tstg	-65 to 150	°C
Lead Temperature (soldering, 10 seconds)	260	°C

Note 1: Stresses beyond those listed under “absolute maximum ratings” may cause permanent damage to the device. These are stress ratings only, and functional operation of the device at these or any other conditions beyond those indicated under “recommended operating conditions” is not implied. Exposure to absolute-maximum-rated conditions for extended periods may affect device reliability.

Note 2: All voltage values are with respect to network ground terminal.

## Thermal Characteristics

Package	$\theta_{JA}$ (°C/W) (See Note 4)	$\theta_{JC}$ (°C/W) (See Note 5)
DFN		
8 pin	73.1	10.7

Note 4: This assumes a FR4 board only.

Note 5: This assumes a 1oz. Copper JEDEC standard board with thermal vias. See Exposed Pad section and application note for more information.

## Recommended Operating Conditions

Parameter	Min	Max	Units
Unregulated Supply Input Voltage (VIN)	5	16 (TS31023) 36 (TS31223)	V
Enable Input (EN)	0	5	V
Regulated Supply Output Voltage (VOUT)	1.25	$V_{IN} - V_{dropout}$	V
Operating Junction Temperature, T <sub>j</sub>	-40	125	°C

## Electrical Characteristics (T=25°C unless otherwise specified)

Electrical characteristics, VIN = 12V, T<sub>j</sub> = 25C, unless otherwise noted

Parameter	Symbol	Conditions	Min.	Typ.	Max.	Units
Input Supply Voltage	VIN	TS31023	5		16	V
		TS31223	5		36	V
Output Voltage	VOUT		1.25		$V_{IN} - V_{dropout}$	V
Feedback Voltage	FB	$V_{IN} = 12V$	1.10	1.20	1.30	V
Output Bypass Capacitor	C <sub>OUT</sub>		1	2.2	4.7	uF
Disabled Current	I <sub>off(VIN)</sub>	EN=0V, V <sub>IN</sub> =12V		1		uA
Quiescent Current	I <sub>qq(VIN)</sub>	EN=5V, I <sub>OUT</sub> = 0		220		uA
Load Capability	I <sub>OUT</sub>				60	mA
DC Line Regulation (TS31023)	V <sub>Line</sub>	$V_{IN} = 5.5V \text{ to } 16V, V_{OUT}=5.0V,$ $I_{OUT} = 5mA$		0.1	0.6	%
DC Line Regulation (TS31223)		$V_{IN} = 5.5V \text{ to } 36V, V_{OUT}=5.0V,$ $I_{OUT} = 5mA$		0.1	0.6	%
DC Load Regulation (TS31023)	V <sub>Load</sub>	$V_{IN} = 12V, V_{OUT}=5.0V,$ $I_{OUT} = 1mA \text{ to } 60mA$		0.02	0.35	%
		$V_{IN} = 6V, V_{OUT}=5.0V,$ $I_{OUT} = 1mA \text{ to } 60mA$		0.02	0.15	%
Current Limit	I <sub>Limit</sub>	$V_{IN} = 12V$		100		mA



# Typical Performance Characteristics

$I_{qq}$  Performance vs. Supply Voltage

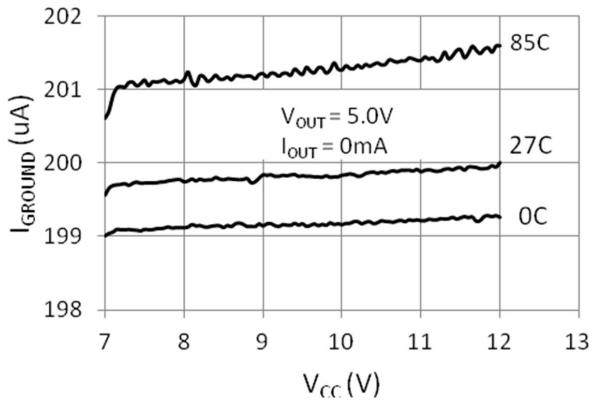

$I_{qq}$  Performance vs. Load Current

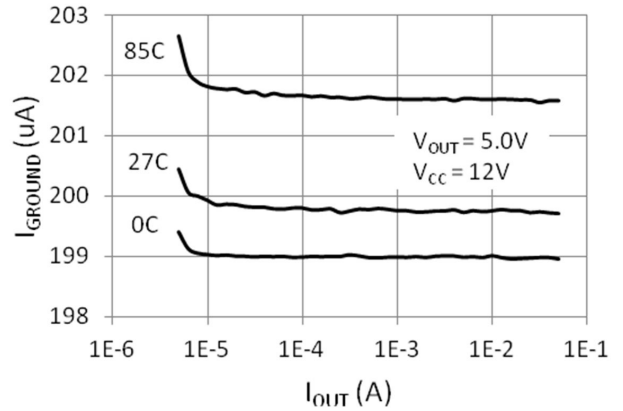

$V_{OUT}$  Performance vs.  $V_{CC}$

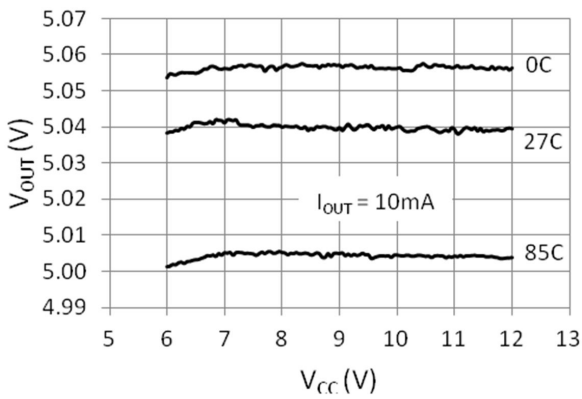

Line Regulation Performance

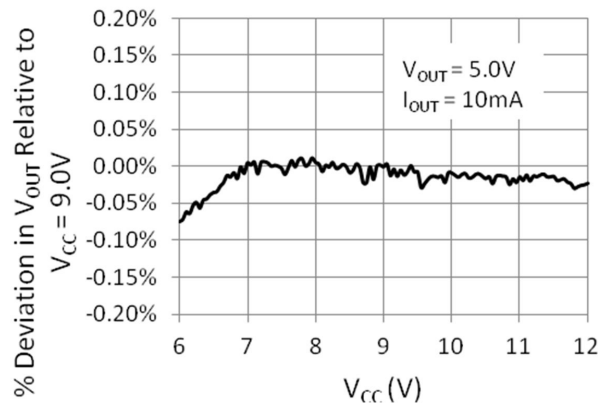

$V_{OUT}$  Performance vs.  $I_{OUT}$

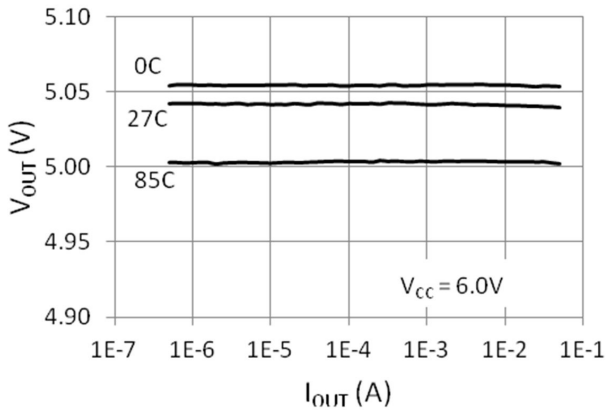

Load Regulation Performance

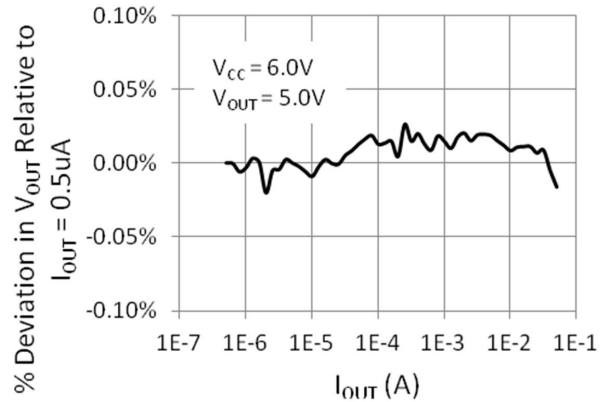

# Typical Performance Characteristics continued

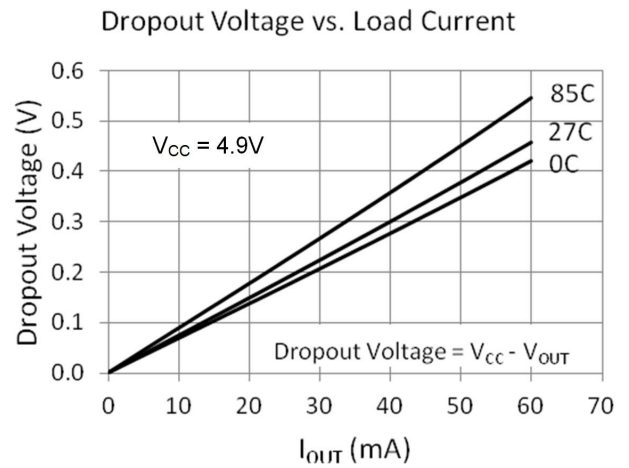
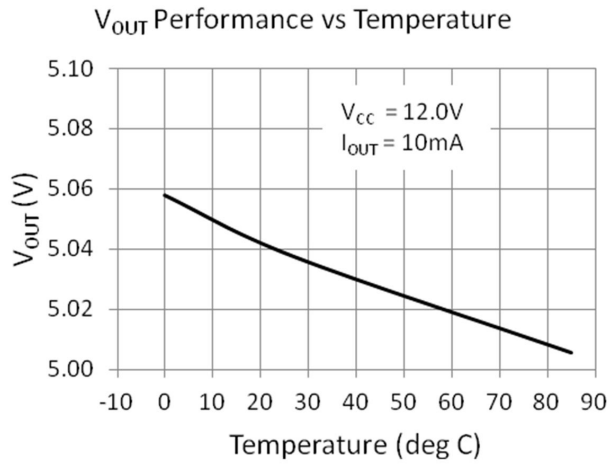
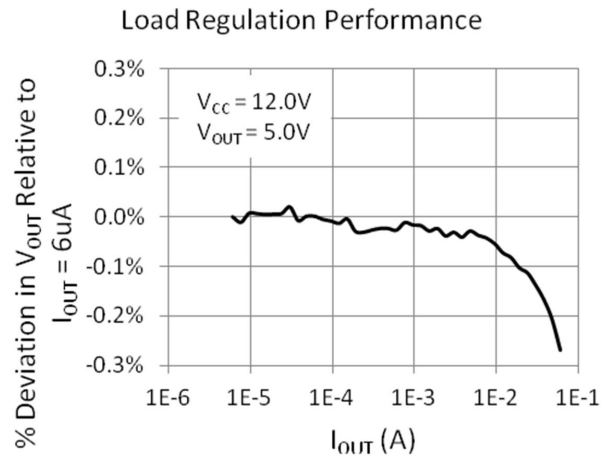
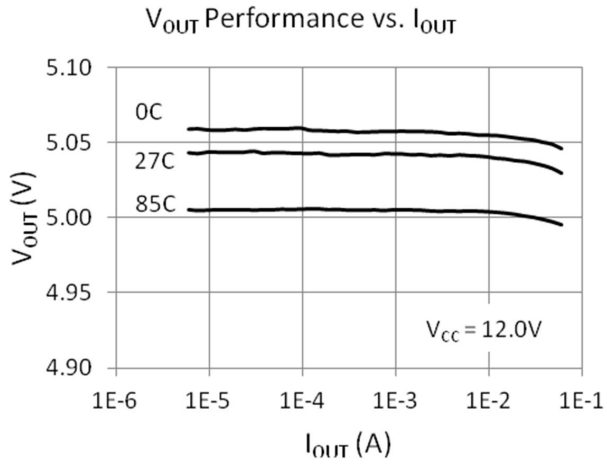

# Package Mechanical Drawings (all dimensions in mm)

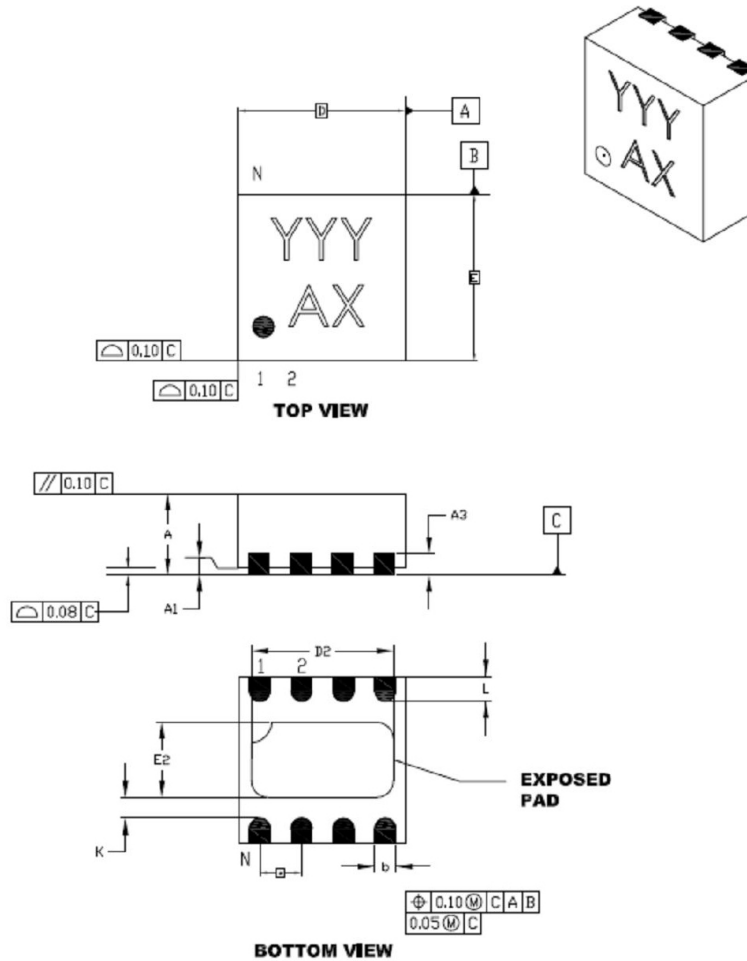

Units		Millimeters		
Dimensions Limits		MIN	NOM	MAX
Number of Pins	N	8		
Pitch	e	0.50 BSC		
Overall Height	A	0.80	0.90	1.00
Standoff	A1	0.00	0.02	0.05
Contact Thickness	A3	0.20 REF		
Overall Length	D	2.00 BSC		
Exposed Pad Width	E2	0.75	0.90	1.00
Overall Width	E	2.00 BSC		
Exposed Pad Length	D2	1.55	1.70	1.80
Contact Width	b	0.18	0.25	0.30
Contact Length	L	0.20	0.30	0.40
Contact-to-Exposed Pad	K	0.20	-	-

## Recommended PCB Land Pattern

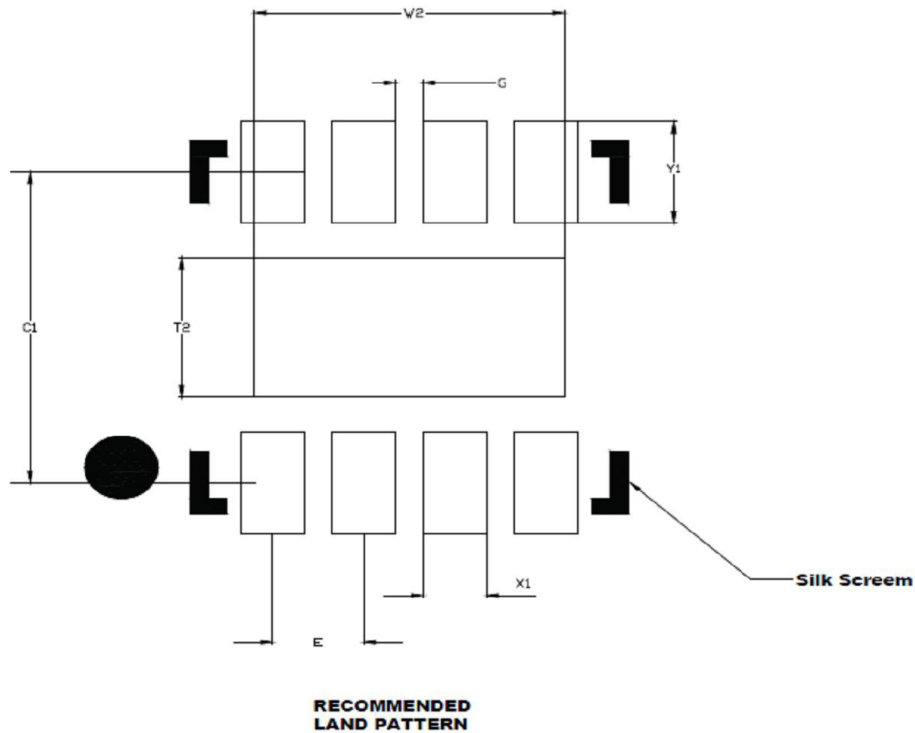

		Units	Millimeters		
		Dimensions Limits	MIN	NOM	MAX
Contact Pitch	E	0.50 BSC			
Optional Center Pad Width	W2	-	-	1.70	
Optional Center Pad Length	T2	-	-	0.90	
Contact Pad Spacing	C1	-	2.00	-	
Contact Pad Width (X8)	X1	-	-	0.35	
Contact Pad Length (X8)	Y1	-	-	0.65	
Distance Between Pads	G	0.15	-	-	

## Ordering Information

**Part Number:**

TS31023-QFNR

TS31223-QFNR





---

#### IMPORTANT NOTICE

Information relating to this product and the application or design described herein is believed to be reliable, however such information is provided as a guide only and Semtech assumes no liability for any errors in this document, or for the application or design described herein. Semtech reserves the right to make changes to the product or this document at any time without notice. Buyers should obtain the latest relevant information before placing orders and should verify that such information is current and complete. Semtech warrants performance of its products to the specifications applicable at the time of sale, and all sales are made in accordance with Semtech's standard terms and conditions of sale.

SEMTECH PRODUCTS ARE NOT DESIGNED, INTENDED, AUTHORIZED OR WARRANTED TO BE SUITABLE FOR USE IN LIFE-SUPPORT APPLICATIONS, DEVICES OR SYSTEMS, OR IN NUCLEAR APPLICATIONS IN WHICH THE FAILURE COULD BE REASONABLY EXPECTED TO RESULT IN PERSONAL INJURY, LOSS OF LIFE OR SEVERE PROPERTY OR ENVIRONMENTAL DAMAGE. INCLUSION OF SEMTECH PRODUCTS IN SUCH APPLICATIONS IS UNDERSTOOD TO BE UNDERTAKEN SOLELY AT THE CUSTOMER'S OWN RISK. Should a customer purchase or use Semtech products for any such unauthorized application, the customer shall indemnify and hold Semtech and its officers, employees, subsidiaries, affiliates, and distributors harmless against all claims, costs damages and attorney fees which could arise.

The Semtech name and logo are registered trademarks of the Semtech Corporation. Triune Systems, L.L.C. is now a wholly-owned subsidiary of Semtech Corporation. The Triune Systems® name and logo, MPPT-lite™, and nanoSmart® are trademarks of Triune Systems, L.L.C. in the U.S.A. All other trademarks and trade names mentioned may be marks and names of Semtech or their respective companies. Semtech reserves the right to make changes to, or discontinue any products described in this document without further notice. Semtech makes no warranty, representation or guarantee, express or implied, regarding the suitability of its products for any particular purpose. All rights reserved.

© Semtech 2015

---

#### Contact Information

Semtech Corporation  
200 Flynn Road, Camarillo, CA 93012  
Phone: (805) 498-2111, Fax: (805) 498-3804  
[www.semtech.com](http://www.semtech.com)