



Chipsmall Limited consists of a professional team with an average of over 10 year of expertise in the distribution of electronic components. Based in Hongkong, we have already established firm and mutual-benefit business relationships with customers from,Europe,America and south Asia,supplying obsolete and hard-to-find components to meet their specific needs.

With the principle of “Quality Parts,Customers Priority,Honest Operation,and Considerate Service”,our business mainly focus on the distribution of electronic components. Line cards we deal with include Microchip,ALPS,ROHM,Xilinx,Pulse,ON,Everlight and Freescale. Main products comprise IC,Modules,Potentiometer,IC Socket,Relay,Connector.Our parts cover such applications as commercial,industrial, and automotives areas.

We are looking forward to setting up business relationship with you and hope to provide you with the best service and solution. Let us make a better world for our industry!



## Contact us

Tel: +86-755-8981 8866 Fax: +86-755-8427 6832

Email & Skype: info@chipsmall.com Web: www.chipsmall.com

Address: A1208, Overseas Decoration Building, #122 Zhenhua RD., Futian, Shenzhen, China



## Low-power single operational amplifier

Datasheet – production data

### Features

- Large output voltage swing
  - 0 to 3.5 V min. ( $V_{CC} = 5\text{ V}$ )
- Low supply current: 500  $\mu\text{A}$
- Low input bias current: 20 nA
- Low input offset voltage
  - 2 mV max. for TS321A
  - 4 mV max. for TS321
- Wide power supply range
  - Single supply: +3 to +30 V
  - Dual supplies:  $\pm 1.5$  to  $\pm 15\text{ V}$
- Stable with high capacitive loads

### Description

The TS321 device is intended for cost-sensitive applications where space saving is of great importance. This bipolar op amp offers the benefits of a reduced component size (SOT23-5 package) with specifications that match (or are better than) industry standard devices (such as the popular LM358A, LM324 devices, and as such). The TS321 device has an input common mode range ( $V_{icm}$ ) that includes ground and therefore can be employed in single supply applications.

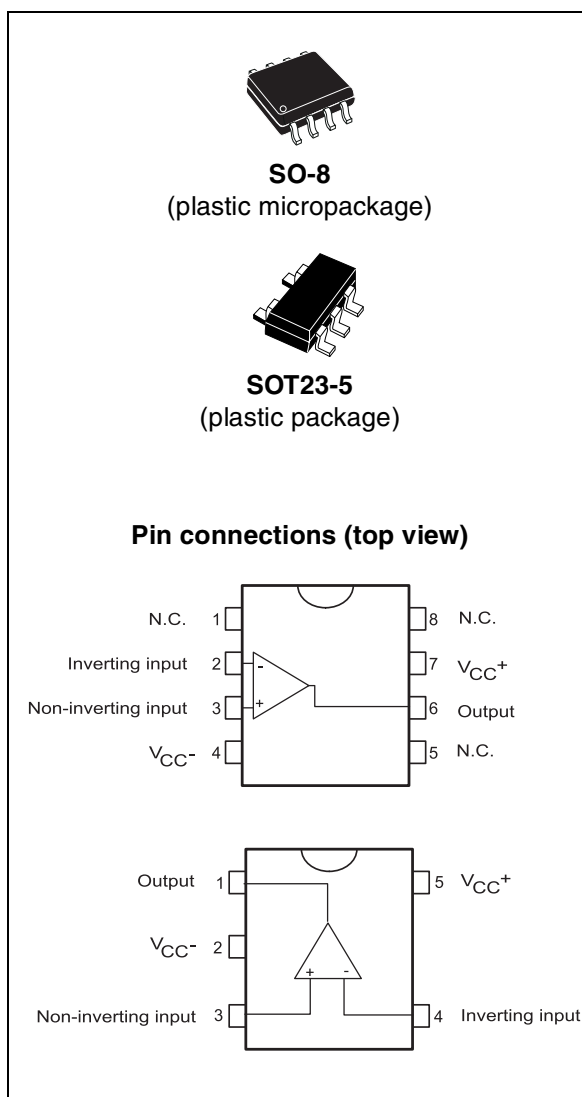

# 1 Circuit schematics

Figure 1. Schematic diagram

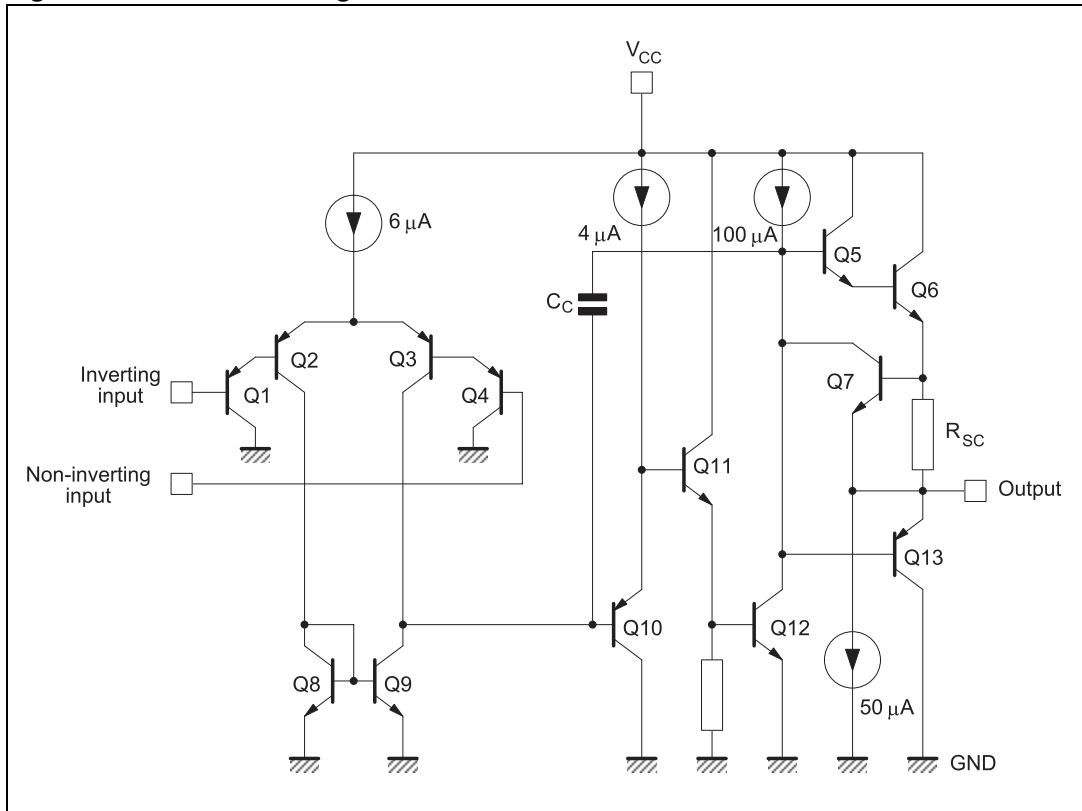

## 2 Absolute maximum ratings and operating conditions

**Table 1. Absolute maximum ratings**

Symbol	Parameter	Value	Unit	
$V_{CC}^+$	Supply voltage	$\pm 16$ to 32	V	
$V_i$	Input voltage	-0.3 to +32	V	
$V_{id}$	Differential input voltage	+32	V	
	Output short-circuit duration <sup>(1)</sup>	Infinite		
$I_{in}$	Input current <sup>(2)</sup>	50	mA	
$T_{stg}$	Storage temperature range	-65 to +150	°C	
$T_j$	Maximum junction temperature	+150	°C	
$R_{thja}$	Thermal resistance junction-to-ambient <sup>(3)</sup>		°C/W	
	SOT23-5 SO-8	250 125		
$R_{thjc}$	Thermal resistance junction-to-case <sup>(3)</sup>		°C/W	
	SOT23-5 SO-8	81 40		
ESD	HBM: human body model <sup>(4)</sup>	300	V	
	MM: machine model <sup>(5)</sup>	200		
	CDM: charged device model <sup>(6)</sup>	SOT23-5		1000
		SO-8		1500

- Short-circuits from the output to  $V_{CC}$  can cause excessive heating if  $V_{CC} > 15$  V. The maximum output current is approximately 40 mA independent of the magnitude of  $V_{CC}$ .
- This input current only exists when the voltage at any of the input leads is driven negative. It is due to the collector-base junction of the input PNP transistor becoming forward biased and thereby acting as input diodes clamps. In addition to this diode action, there is also NPN parasitic action on the IC chip. This transistor action can cause the output voltages of the op amps to go to the  $V_{CC}$  voltage level (or to ground for a large overdrive) for the time during which an input is driven negative. This is not destructive and normal output is restored when the input voltage goes back above -0.3 V.
- Short-circuits can cause excessive heating. Destructive dissipation can result from simultaneous short-circuits on all amplifiers. All values are typical.
- Human body model: a 100 pF capacitor is charged to the specified voltage, then discharged through a 1.5 k $\Omega$  resistor between two pins of the device. This is done for all couples of connected pin combinations while the other pins are floating.
- Machine model: a 200 pF capacitor is charged to the specified voltage, then discharged directly between two pins of the device with no external series resistor (internal resistor < 5  $\Omega$ ). This is done for all couples of connected pin combinations while the other pins are floating.
- Charged device model: all pins and the package are charged together to the specified voltage and then discharged directly to ground through only one pin. This is done for all pins. The CDM value applies to SO-8 only.

Table 2. Operating conditions

Symbol	Parameter	Value	Unit
$V_{CC^+}$	Supply voltage	3 to 30	V
$V_{icm}$	Common mode input voltage range ( $V_{CC^+} = 30$ V) $T_{amb} = +25$ °C $T_{min} \leq T_{amb} \leq T_{max}$	0 to $V_{CC^+} - 1.5$ 0 to $V_{CC^+} - 2$	V
$T_{oper}$	Operating free air temperature range	-40 to +125	°C

### 3 Electrical characteristics

**Table 3. Electrical characteristics at  $V_{CC}^+ = +5\text{ V}$ ,  $V_{CC}^- = \text{ground}$ ,  $V_o = 1.4\text{ V}$ ,  $T_{\text{amb}} = +25\text{ °C}$  (unless otherwise specified)**

Symbol	Parameter	Conditions	Min.	Typ.	Max.	Unit
$V_{io}$	Input offset voltage <sup>(1)</sup>	TS321 TS321A $T_{\text{min}} \leq T_{\text{amb}} \leq T_{\text{max}}$ TS321 TS321A		0.5	4 2 5 3	mV
$I_{io}$	Input offset current	$T_{\text{min}} \leq T_{\text{amb}} \leq T_{\text{max}}$		2	30 50	nA
$I_{ib}$	Input bias current <sup>(2)</sup>	$T_{\text{min}} \leq T_{\text{amb}} \leq T_{\text{max}}$		20	150 200	nA
$A_{vd}$	Large signal voltage gain	$V_{CC}^+ = +15\text{ V}$ , $R_L = 2\text{ k}\Omega$ , $V_o = 1.4\text{ to }11.4\text{ V}$ $T_{\text{min}} \leq T_{\text{amb}} \leq T_{\text{max}}$	50 25	100		V/mV
SVR	Supply voltage rejection ratio	$R_s \leq 10\text{ k}\Omega$ , $V_{CC}^+ = 5\text{ to }30\text{ V}$	65	110		dB
$I_{CC}$	Supply current, no load	$V_{CC}^+ = +5\text{ V}$ $V_{CC}^+ = +30\text{ V}$ $T_{\text{min}} \leq T_{\text{amb}} \leq T_{\text{max}}$ $V_{CC}^+ = +5\text{ V}$ $V_{CC}^+ = +30\text{ V}$		500 600 600	800 900 900 1000	$\mu\text{A}$
CMR	Common mode rejection ratio	$R_s \leq 10\text{ k}\Omega$	65	85		dB
$I_{\text{source}}$	Output current source	$V_{id} = +1\text{ V}$ $V_{CC}^+ = +15\text{ V}$ , $V_o = +2\text{ V}$	20	40		mA
$I_{\text{sink}}$	Output sink current	$V_{id} = -1\text{ V}$ $V_{CC}^+ = +15\text{ V}$ , $V_o = +2\text{ V}$ $V_{CC}^+ = +15\text{ V}$ , $V_o = +0.2\text{ V}$	10 12	20 50		mA $\mu\text{A}$
$I_o$	Short-circuit to ground	$V_{CC}^+ = +15\text{ V}$		40	60	mA
$V_{OH}$	High level output voltage	$V_{CC}^+ = +30\text{ V}$ , $R_L = 2\text{ k}\Omega$ $T_{\text{min}} \leq T_{\text{amb}} \leq T_{\text{max}}$ $V_{CC}^+ = +30\text{ V}$ , $R_L = 10\text{ k}\Omega$ $T_{\text{min}} \leq T_{\text{amb}} \leq T_{\text{max}}$ $V_{CC}^+ = +5\text{ V}$ , $R_L = 2\text{ k}\Omega$ $T_{\text{min}} \leq T_{\text{amb}} \leq T_{\text{max}}$	26 25.5 27 26.5 3.5 3	27 28		V
$V_{OL}$	Low level output voltage	$R_L = 10\text{ k}\Omega$ $T_{\text{min}} \leq T_{\text{amb}} \leq T_{\text{max}}$		5	15 20	mV
SR	Slew rate	$V_{CC}^+ = +15\text{ V}$ , $V_i = 0.5\text{ to }3\text{ V}$ , $R_L = 2\text{ k}\Omega$ $C_L = 100\text{ pF}$ , unity gain		0.4		V/ $\mu\text{s}$
GBP	Gain bandwidth product	$V_{CC}^+ = 30\text{ V}$ , $f = 100\text{ kHz}$ , $V_{in} = 10\text{ mV}$ , $R_L = 2\text{ k}\Omega$ , $C_L = 100\text{ pF}$		0.8		MHz
$\phi_m$	Phase margin			60		Degrees

**Table 3. Electrical characteristics at  $V_{CC}^+ = +5\text{ V}$ ,  $V_{CC}^- = \text{ground}$ ,  $V_o = 1.4\text{ V}$ ,  $T_{\text{amb}} = +25\text{ °C}$  (unless otherwise specified) (continued)**

Symbol	Parameter	Conditions	Min.	Typ.	Max.	Unit
THD	Total harmonic distortion	$f = 1\text{ kHz}$ , $A_V = 20\text{ dB}$ , $R_L = 2\text{ k}\Omega$ , $V_o = 2\text{ V}_{pp}$ , $C_L = 100\text{ pF}$ , $V_{CC}^+ = +30\text{ V}$		0.015		%
en	Equivalent input noise voltage	$f = 1\text{ kHz}$ , $R_s = 100\ \Omega$ , $V_{CC}^+ = +30\text{ V}$		40		$\frac{\text{nV}}{\sqrt{\text{Hz}}}$

- $V_o = 1.4\text{ V}$ ,  $R_s = 0\ \Omega$ ,  $5\text{ V} < V_{CC}^+ < 30\text{ V}$ ,  $0 < V_{icm} < V_{CC}^+ - 1.5\text{ V}$ .
- The direction of the input current is *out* of the IC. This current is essentially constant and independent of the state of the output, therefore there is no change in the load on the input lines.

**Figure 2. Current consumption versus temperature**

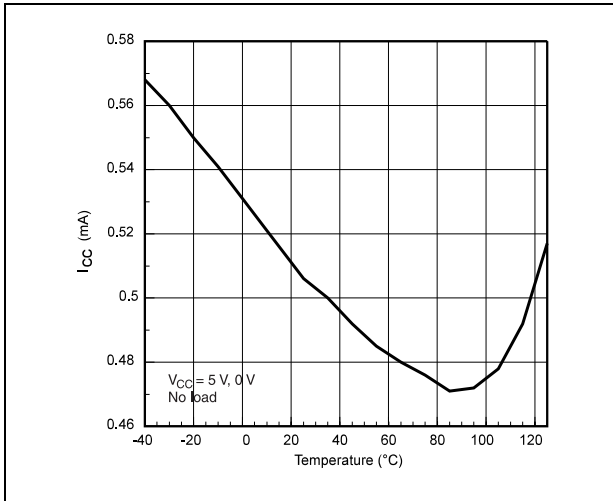

**Figure 3. AC-coupled inverting amplifier**

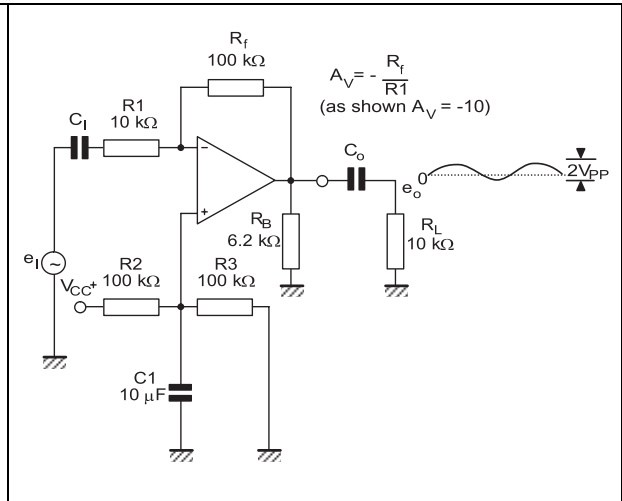

**Figure 4. Non-inverting DC gain**

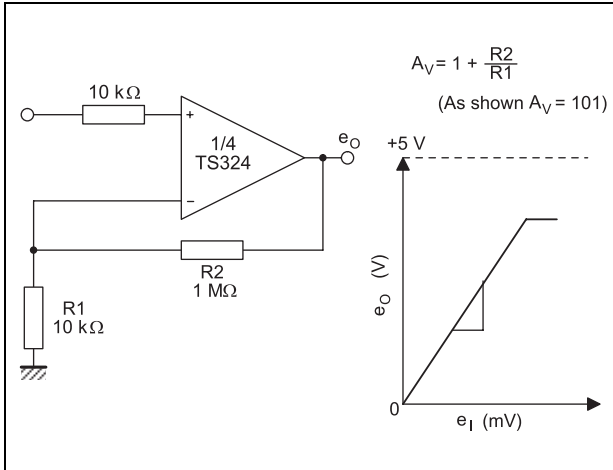

**Figure 5. AC-coupled non-inverting amplifier**

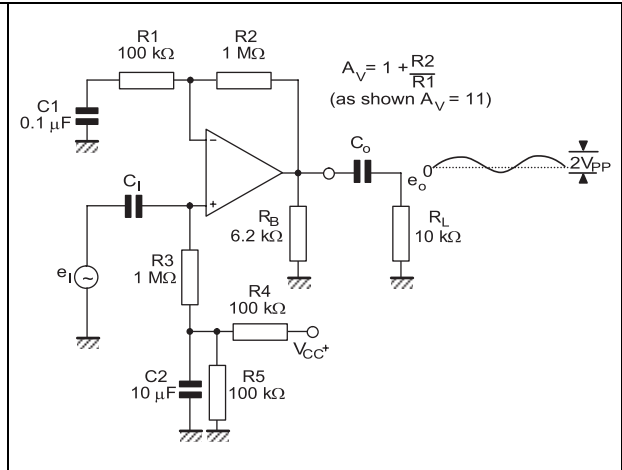

**Figure 6. DC summing amplifier**

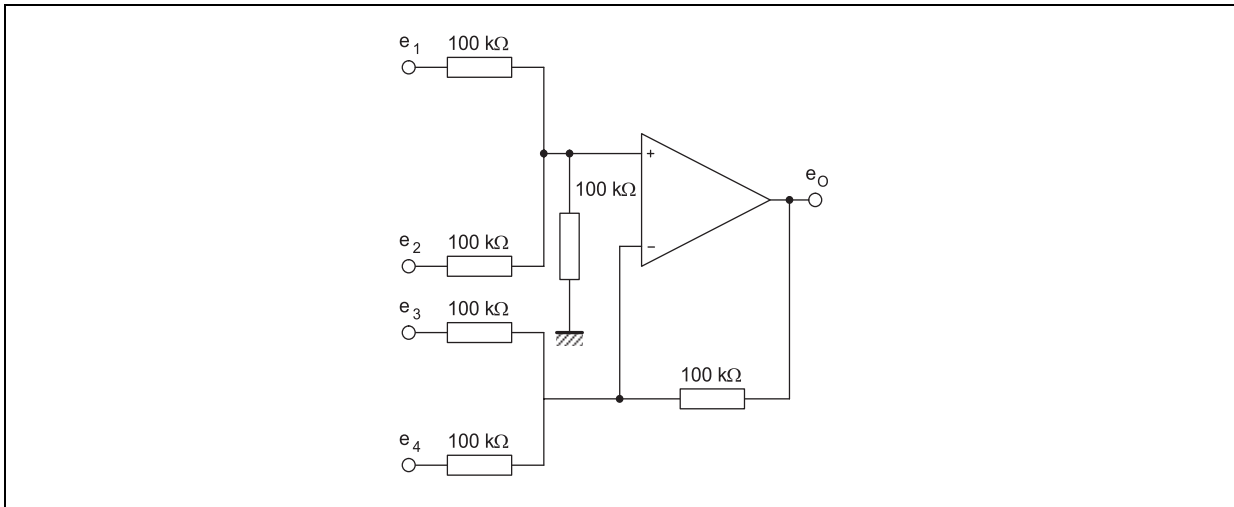

## 4 Macromodel

### 4.1 Important note concerning this macromodel

Note the following remarks before using the macromodel.

- All models are a trade-off between accuracy and complexity (that is, simulation time).
- Macromodels are not a substitute to breadboarding; rather, they confirm the validity of a design approach and help to select surrounding component values.
- A macromodel emulates the **nominal** performance of a **typical** device within **specified operating conditions** (temperature, supply voltage, for example). Thus the macromodel is often not as exhaustive as the datasheet, its purpose is to illustrate the main parameters of the product.

Data derived from macromodels used outside of the specified conditions ( $V_{CC}$ , temperature, for example) or even worse, outside of the device's operating conditions ( $V_{CC}$ ,  $V_{icm}$ , for example), is not reliable in any way.

### 4.2 Macromodel code

```
** Standard Linear Ics Macromodels, 1993.
** CONNECTIONS :
* 1 INVERTING INPUT
* 2 NON-INVERTING INPUT
* 3 OUTPUT
* 4 POSITIVE POWER SUPPLY
* 5 NEGATIVE POWER SUPPLY
.SUBCKT TS321 1 2 3 4 5
*****
.MODEL MDTH D IS=1E-8 KF=3.104131E-15 CJO=10F
* INPUT STAGE
CIP 2 5 1.000000E-12
CIN 1 5 1.000000E-12
EIP 10 5 2 5 1
EIN 16 5 1 5 1
RIP 10 11 2.600000E+01
RIN 15 16 2.600000E+01
RIS 11 15 2.003862E+02
DIP 11 12 MDTH 400E-12
DIN 15 14 MDTH 400E-12
VOFP 12 13 DC 0
VOFN 13 14 DC 0
IPOL 13 5 1.000000E-05
CPS 11 15 3.783376E-09
DINN 17 13 MDTH 400E-12
VIN 17 5 0.000000E+00
DINR 15 18 MDTH 400E-12
```

```

VIP 4 18 2.000000E+00
FCP 4 5 VOFN 3.400000E+01
FCN 5 4 VOFN 3.400000E+01
FIBP 2 5 VOFN 2.000000E-03
FIBN 5 1 VOFN 2.000000E-03
* AMPLIFYING STAGE
FIP 5 19 VOFN 3.600000E+02
FIN 5 19 VOFN 3.600000E+02
RG1 19 5 3.652997E+06
RG2 19 4 3.652997E+06
CC 19 5 6.000000E-09
DOPM 19 22 MDTH 400E-12
DONM 21 19 MDTH 400E-12
HOPM 22 28 VOUT 7.500000E+03
VIPM 28 4 1.500000E+02
HONM 21 27 VOUT 7.500000E+03
VINM 5 27 1.500000E+02
EOUT 26 23 19 5 1
VOUT 23 5 0
ROUT 26 3 20
COUT 3 5 1.000000E-12
DOP 19 25 MDTH 400E-12
VOP 4 25 2.242230E+00
DON 24 19 MDTH 400E-12
VON 24 5 7.922301E-01
.ENDS

```

### 4.3 Electrical characteristics of the macromodel

**Table 4. Electrical characteristics at  $V_{CC}^+ = +3\text{ V}$ ,  $V_{CC}^- = 0\text{ V}$ ,  $R_L, C_L$  connected to  $V_{CC}/2$ ,  $T_{amb} = 25\text{ °C}$  (unless otherwise specified)**

Symbol	Conditions	Value	Unit
$V_{io}$		0	mV
$A_{vd}$	$R_L = 2\text{ k}\Omega$	100	V/mV
$I_{CC}$	No load, per operator	300	$\mu\text{A}$
$V_{icm}$		0 to +3.5	V
$V_{OH}$	$R_L = 2\text{ k}\Omega$	3.5	V
$V_{OL}$	$R_L = 2\text{ k}\Omega$	5	mV
$I_{os}$	$V_o = 0\text{ V}$	40	mA
GBP	$R_L = 2\text{ k}\Omega$ , $C_L = 100\text{ pF}$	0.8	MHz
SR	$R_L = 2\text{ k}\Omega$ , $C_L = 100\text{ pF}$	0.4	V/ $\mu\text{s}$
$\phi_m$	$R_L = 2\text{ k}\Omega$ , $C_L = 100\text{ pF}$	60	Degrees

## 5 Package information

In order to meet environmental requirements, ST offers these devices in different grades of ECOPACK<sup>®</sup> packages, depending on their level of environmental compliance. ECOPACK specifications, grade definitions and product status are available at: [www.st.com](http://www.st.com). ECOPACK is an ST trademark.

## 5.1 SOT23-5 package information

Figure 7. SOT23-5 package outline

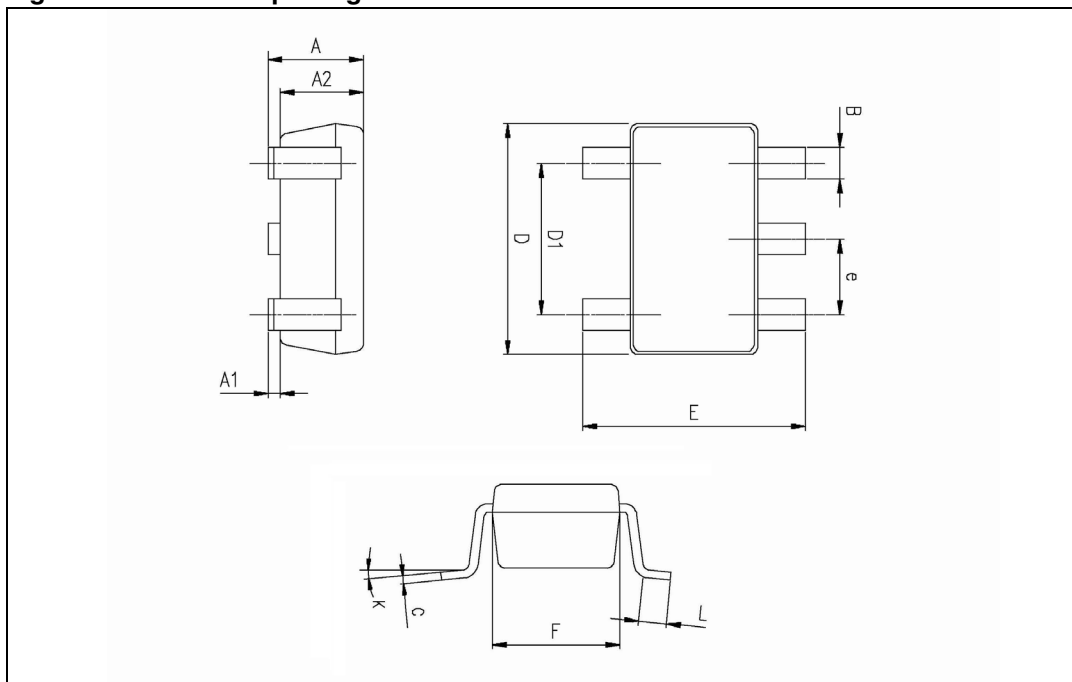

Table 5. SOT23-5 package mechanical data

Symbol	Dimensions					
	Millimeters			Inches		
	Min.	Typ.	Max.	Min.	Typ.	Max.
A	0.90	1.20	1.45	0.035	0.047	0.057
A1			0.15			0.006
A2	0.90	1.05	1.30	0.035	0.041	0.051
B	0.35	0.40	0.50	0.013	0.015	0.019
C	0.09	0.15	0.20	0.003	0.006	0.008
D	2.80	2.90	3.00	0.110	0.114	0.118
D1		1.90			0.075	
e		0.95			0.037	
E	2.60	2.80	3.00	0.102	0.110	0.118
F	1.50	1.60	1.75	0.059	0.063	0.069
L	0.10	0.35	0.60	0.004	0.013	0.023
K	0°		10°			

## 5.2 SO-8 package information

Figure 8. SO-8 package outline

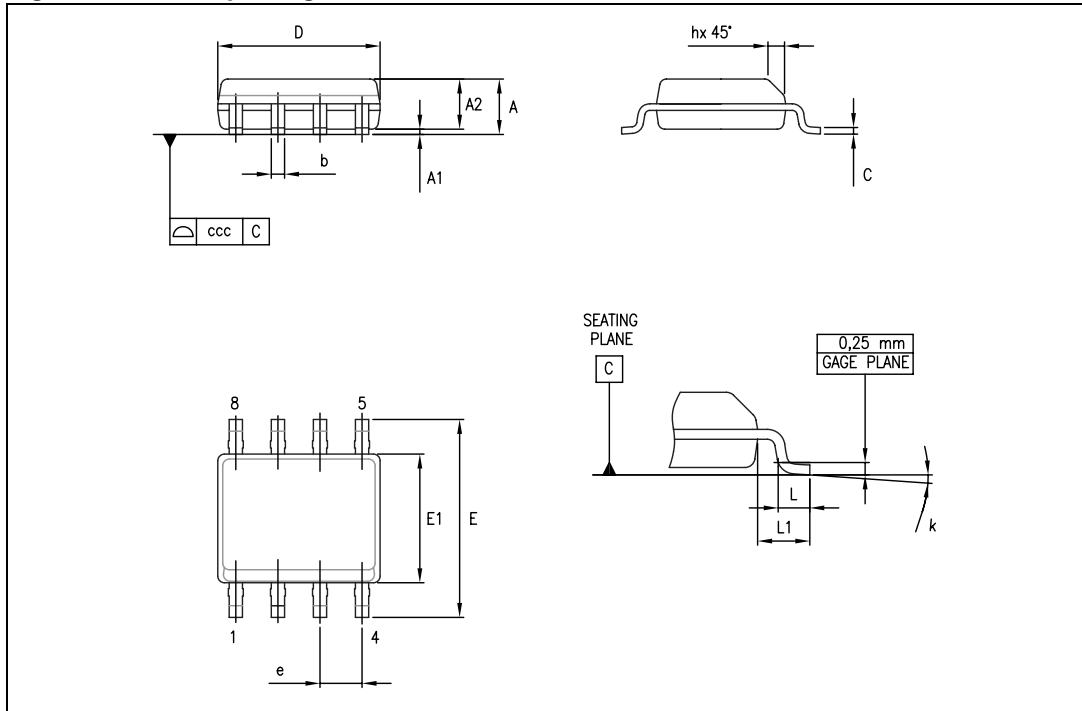

Table 6. SO-8 package mechanical data

Symbol	Dimensions					
	Millimeters			Inches		
	Min.	Typ.	Max.	Min.	Typ.	Max.
A			1.75			0.069
A1	0.10		0.25	0.004		0.010
A2	1.25			0.049		
b	0.28		0.48	0.011		0.019
c	0.17		0.23	0.007		0.010
D	4.80	4.90	5.00	0.189	0.193	0.197
H	5.80	6.00	6.20	0.228	0.236	0.244
E1	3.80	3.90	4.00	0.150	0.154	0.157
e		1.27			0.050	
h	0.25		0.50	0.010		0.020
L	0.40		1.27	0.016		0.050
L1						
k	0°		8°	1°		8°
ccc			0.10			0.004

## 6 Ordering information

**Table 7. Order codes**

Part number	Temperature range	Package	Packaging	Marking
TS321ILT	-40 °C, +125 °C	SOT23-5L	Tape and reel	K401
TS321AILT				K402
TS321ID/IDT		SO-8	Tube or tape and reel	321I
TS321AID/AIDT				321AI
TS321IYLT <sup>(1)</sup>		SOT23-5L (automotive grade level)	Tape and reel	K406
TS321AIYLT <sup>(1)</sup>				K407

1. Qualified and characterized according to AEC Q100 and Q003 or equivalent, advanced screening according to AEC Q001 and Q 002 or equivalent.

## 7 Revision history

**Table 8. Document revision history**

Date	Revision	Changes
30-Jun-2001	1	Initial release.
04-Jul-2005	2	PPAP references inserted in the datasheet, see order codes table. ESD protection inserted in <a href="#">Table 1: Absolute maximum ratings</a> .
06-Sep-2005	3	Correction of errors in package names and markings in order codes table. Minor grammatical and formatting corrections.
12-Dec-2005	4	Missing PPAP references inserted, see order codes table. Thermal resistance junction to ambient and thermal resistance junction to case information added in <a href="#">Table 1: Absolute maximum ratings</a> . Macromodel updated see <a href="#">Section 4: Macromodel</a> .
08-Nov-2007	5	Added CDM value for SO-8 in <a href="#">Table 1: Absolute maximum ratings</a> . Added $T_j$ value in <a href="#">Table 1: Absolute maximum ratings</a> . Macromodel updated see <a href="#">Section 4: Macromodel</a> . Reformatted package information. Added footnote in <a href="#">Table 7: Order codes</a> . Removed TS321IYD/IYDT and TS321AIYD/AIYDT order codes.
08-Jul-2008	6	Added CDM value for SOT23-5 package in <a href="#">Table 1: Absolute maximum ratings</a> .
10-May-2010	7	Updated package information in <a href="#">Chapter 5</a> .
12-Sep-2012	8	Qualified status of TS321IYLT and TS321AIYLT order codes in <a href="#">Table 7</a> , minor corrections throughout document.

**Please Read Carefully:**

Information in this document is provided solely in connection with ST products. STMicroelectronics NV and its subsidiaries ("ST") reserve the right to make changes, corrections, modifications or improvements, to this document, and the products and services described herein at any time, without notice.

All ST products are sold pursuant to ST's terms and conditions of sale.

Purchasers are solely responsible for the choice, selection and use of the ST products and services described herein, and ST assumes no liability whatsoever relating to the choice, selection or use of the ST products and services described herein.

No license, express or implied, by estoppel or otherwise, to any intellectual property rights is granted under this document. If any part of this document refers to any third party products or services it shall not be deemed a license grant by ST for the use of such third party products or services, or any intellectual property contained therein or considered as a warranty covering the use in any manner whatsoever of such third party products or services or any intellectual property contained therein.

**UNLESS OTHERWISE SET FORTH IN ST'S TERMS AND CONDITIONS OF SALE ST DISCLAIMS ANY EXPRESS OR IMPLIED WARRANTY WITH RESPECT TO THE USE AND/OR SALE OF ST PRODUCTS INCLUDING WITHOUT LIMITATION IMPLIED WARRANTIES OF MERCHANTABILITY, FITNESS FOR A PARTICULAR PURPOSE (AND THEIR EQUIVALENTS UNDER THE LAWS OF ANY JURISDICTION), OR INFRINGEMENT OF ANY PATENT, COPYRIGHT OR OTHER INTELLECTUAL PROPERTY RIGHT.**

**UNLESS EXPRESSLY APPROVED IN WRITING BY TWO AUTHORIZED ST REPRESENTATIVES, ST PRODUCTS ARE NOT RECOMMENDED, AUTHORIZED OR WARRANTED FOR USE IN MILITARY, AIR CRAFT, SPACE, LIFE SAVING, OR LIFE SUSTAINING APPLICATIONS, NOR IN PRODUCTS OR SYSTEMS WHERE FAILURE OR MALFUNCTION MAY RESULT IN PERSONAL INJURY, DEATH, OR SEVERE PROPERTY OR ENVIRONMENTAL DAMAGE. ST PRODUCTS WHICH ARE NOT SPECIFIED AS "AUTOMOTIVE GRADE" MAY ONLY BE USED IN AUTOMOTIVE APPLICATIONS AT USER'S OWN RISK.**

Resale of ST products with provisions different from the statements and/or technical features set forth in this document shall immediately void any warranty granted by ST for the ST product or service described herein and shall not create or extend in any manner whatsoever, any liability of ST.

ST and the ST logo are trademarks or registered trademarks of ST in various countries.

Information in this document supersedes and replaces all information previously supplied.

The ST logo is a registered trademark of STMicroelectronics. All other names are the property of their respective owners.

© 2012 STMicroelectronics - All rights reserved

STMicroelectronics group of companies

Australia - Belgium - Brazil - Canada - China - Czech Republic - Finland - France - Germany - Hong Kong - India - Israel - Italy - Japan - Malaysia - Malta - Morocco - Philippines - Singapore - Spain - Sweden - Switzerland - United Kingdom - United States of America

[www.st.com](http://www.st.com)

