



Chipsmall Limited consists of a professional team with an average of over 10 year of expertise in the distribution of electronic components. Based in Hongkong, we have already established firm and mutual-benefit business relationships with customers from,Europe,America and south Asia,supplying obsolete and hard-to-find components to meet their specific needs.

With the principle of “Quality Parts,Customers Priority,Honest Operation,and Considerate Service”,our business mainly focus on the distribution of electronic components. Line cards we deal with include Microchip,ALPS,ROHM,Xilinx,Pulse,ON,Everlight and Freescale. Main products comprise IC,Modules,Potentiometer,IC Socket,Relay,Connector.Our parts cover such applications as commercial,industrial, and automotives areas.

We are looking forward to setting up business relationship with you and hope to provide you with the best service and solution. Let us make a better world for our industry!



Contact us

Tel: +86-755-8981 8866 Fax: +86-755-8427 6832

Email & Skype: info@chipsmall.com Web: www.chipsmall.com

Address: A1208, Overseas Decoration Building, #122 Zhenhua RD., Futian, Shenzhen, China



1.24V Programmable Shunt Voltage Reference

- Adjustable output voltage: 1.24 to 24V
- Several precision @ 25°C
±2%, ±1%, ±0.5% and ±0.25%
- Sink current capability: 0.4 to 100mA
- Industrial temperature range: -40 to +125°C
- Performances compatible with industry standard TL431

Description

The TS3431 is a programmable shunt voltage reference with guaranteed temperature stability over the entire temperature range of operation (-40 to +125°C). The output voltage may be set to any value between 1.24V and 24V with an external resistor bridge.

Available in SOT23-3 surface mount package, it can be designed in applications where space saving is a critical issue.

Applications

- Computers
- Instrumentation
- Battery chargers
- Switch mode power supply
- Battery operated equipments

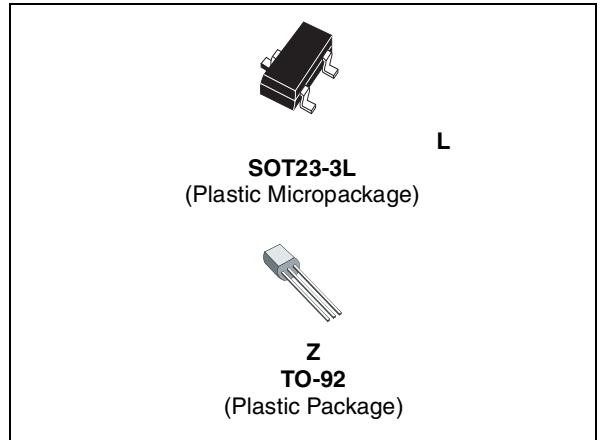

Pin Connections (top view)

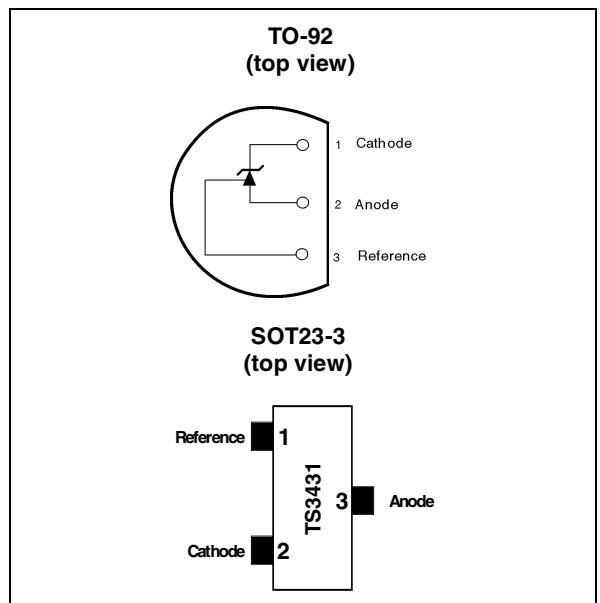

Order Codes

Part Number	Temperature Range	Package	Packaging	Marking
TS3431ILT/AILT/BILT/CILT	-40, +125°C	SOT23-3L	Tape & Reel	L280-L281 L282-L283
TS3431IZ/AIZ/BIZ/CIZ			Bulk	
TS3431IZT/AIZT/BIZT/CIZT		TO-92	Tape & Reel	
TS3431IZ-AP/AIZ-AP/BIZ-AP/CIZ-AP			Ammo pack	

1 Absolute Maximum Ratings

Table 1. Key parameters and their absolute maximum ratings

Symbol	Parameter	Value	Unit
V_{KA}	Cathode to Anode Voltage	25	V
I_K	Reverse Breakdown Current	-100 to +150	mA
I_{REF}	Reference Current	-0.05 to 10	mA
P_D	Power Dissipation ¹ SOT23-3 TO92	360 625	mW
T_{std}	Storage Temperature	-65 to +150	°C
ESD	Human Body Model (HBM)	2	kV
	Machine Model (MM)	200	V
T_{lead}	Lead Temperature (soldering, 10 seconds)	250	°C

1) P_D has been calculated with $T_{amb} = 25^\circ\text{C}$ and $T_j = 150^\circ\text{C}$ and $R_{thjc} = 66^\circ\text{C/W}$, $R_{thja} = 200^\circ\text{C/W}$ for the TO92 package
 $R_{thjc} = 110^\circ\text{C/W}$, $R_{thja} = 340^\circ\text{C/W}$ for the SOT23-3L package

Table 2. Operating Conditions

Symbol	Parameter	Value	Unit
I_K	Cathode Operating Current	0.5 to 100	mA
V_K	Cathode Operating Voltage	1.24 to 24	V
T_{oper}	Operating Free Air Temperature Range	-40 to +125	°C

2 Electrical Characteristics

Table 3. Tamb = 25°C (unless otherwise specified)

Symbol	Parameter	Test Condition	Min.	Typ.	Max.	Unit
V_K	Reference input voltage $I_K = 10\text{mA}$	TS3431 (2%)	1.215	1.24	1.265	V
		TS3431A (1%)	1.228		1.252	
		TS3431B (0.5%)	1.234		1.246	
		TS3431C (0.25%)	1.237		1.243	
ΔV_K	Variation of reference input voltage over temperature	$0^\circ\text{C} < T < +70^\circ\text{C}$			10	mV
		$-40^\circ\text{C} < T < +105^\circ\text{C}$			18	
		$-40^\circ\text{C} < T < +125^\circ\text{C}$			21	
T_C	Temperature coefficient	$-40^\circ\text{C} < T < +125^\circ\text{C}$			100	ppm/°C
$I_{K\text{MIN}}$	Minimum Operating Current	$T = 25^\circ\text{C}$		0.35	0.4	mA
		$-40^\circ\text{C} < T < +125^\circ\text{C}$			0.5	
$\left \frac{\Delta V_{\text{ref}}}{\Delta V_{\text{ka}}} \right $	Ratio of change in reference input voltage to change in cathode to anode voltage	$I_K=10\text{mA}$ $V_K= 24 \text{ to } 1.24\text{V}$		1.2	1.5	mV/V
		$-40^\circ\text{C} < T < +125^\circ\text{C}$			2	
I_{REF}	Reference input current $I_K=10\text{mA}$, $R1=10\text{K}\Omega$, $R2=+\infty$	$T=25^\circ\text{C}$		0.9	1.5	μA
		$-40^\circ\text{C} < T < +125^\circ\text{C}$			2	
ΔI_{REF}	Reference input current deviation $I_K=10\text{mA}$, $R1=10\text{K}\Omega$, $R2=+$	$0^\circ\text{C} < T < +70^\circ\text{C}$		0.5	1	μA
		$-40^\circ\text{C} < T < +125^\circ\text{C}$		0.9	1.5	
I_{OFF}	Off-state cathode current $V_K=24\text{V}$	$T=25^\circ\text{C}$		35	500	nA
		$-40^\circ\text{C} < T < +105^\circ\text{C}$			1000	
		$-40^\circ\text{C} < T < +125^\circ\text{C}$			2000	
R_{KA}	Reverse Static Impedance	$I_K = 1 \text{ to } 100\text{mA}$		0.2	0.4	Ω
E_N	Wideband Noise	$I_K = 10\text{mA}$ $1\text{kHz} < f < 100\text{kHz}$		100		$\text{nV}/\sqrt{\text{Hz}}$

Note: Limits are 100% production tested at 25°C. Limits over temperature are guaranteed through correlation and by design.

Figure 1. Reference voltage vs. temperature

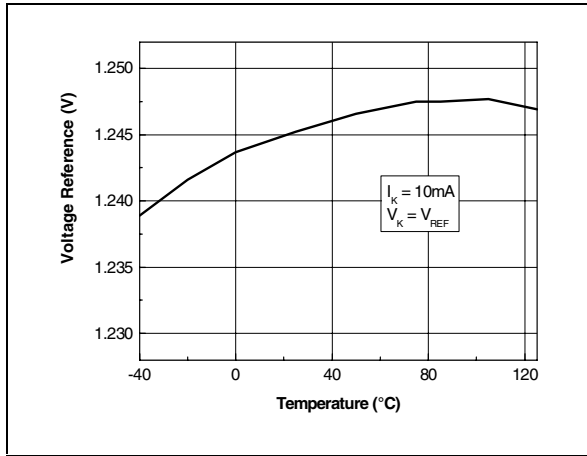

Figure 2. Cathode voltage vs cathode current

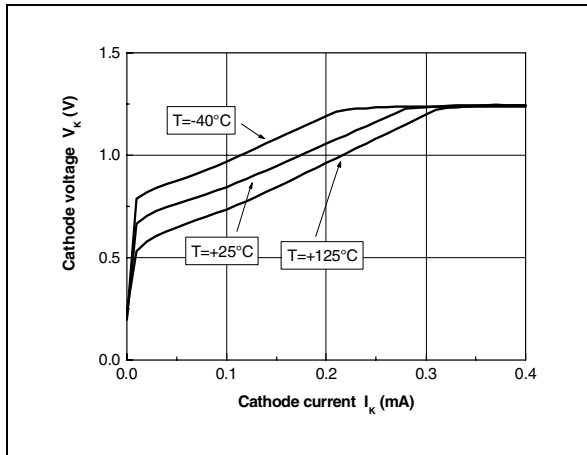

Figure 3. Reference input current vs temperature

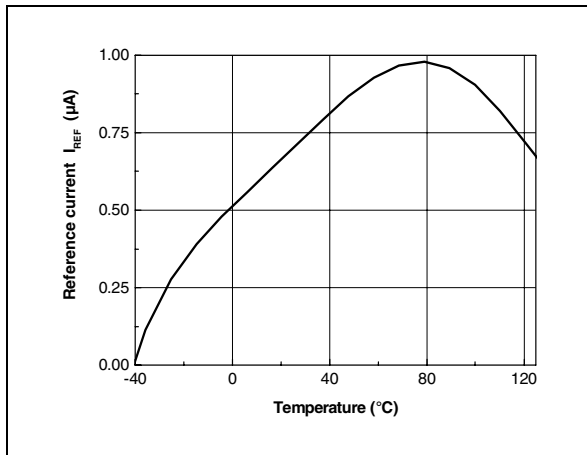

Figure 4. Test circuit for V_K = Vref

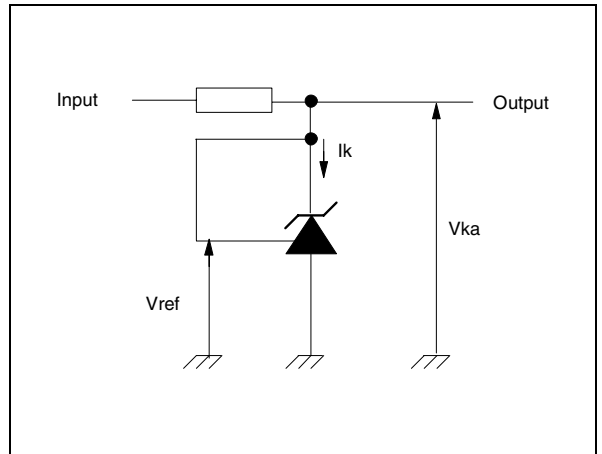

Figure 5. Minimum operating current vs temperature

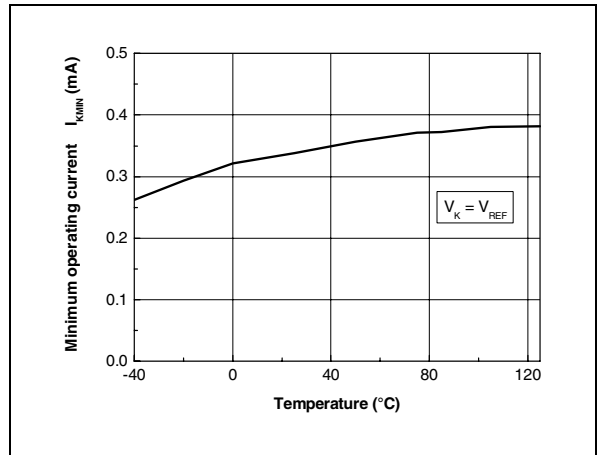

Figure 6. Dynamic impedance vs frequency

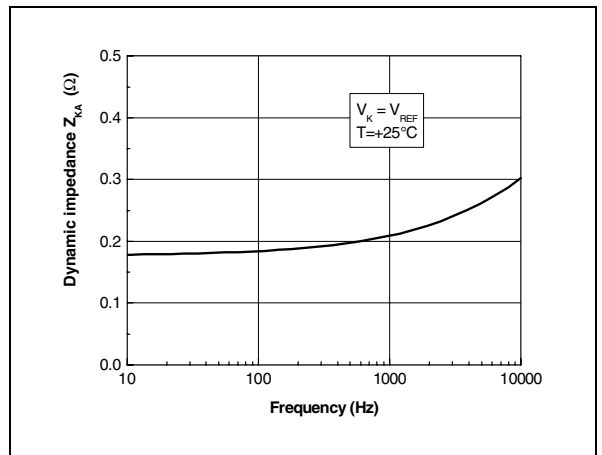

Figure 7. Off-State current vs temperature

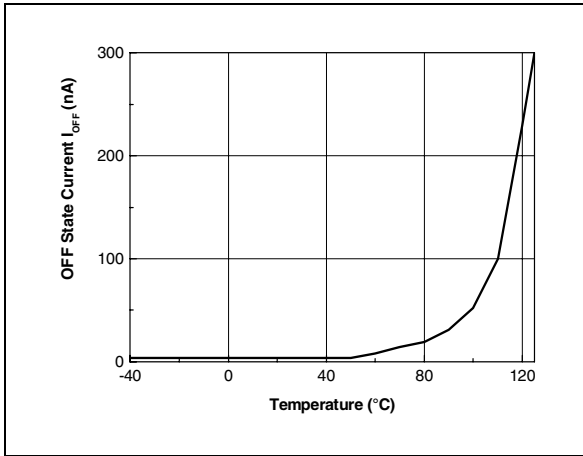

Figure 8. Ratio of change in reference input voltage to change in V_K voltage vs temperature

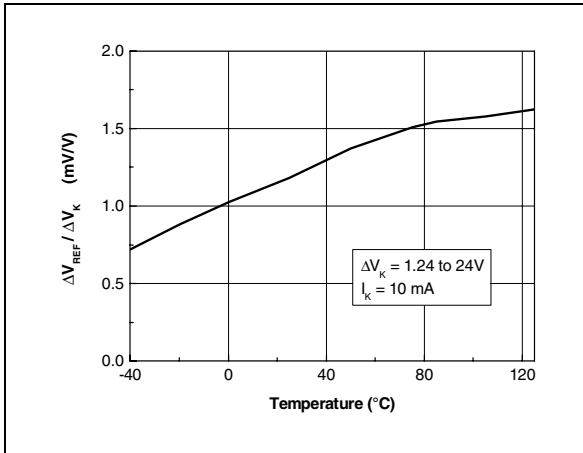

Figure 9. Phase and gain vs frequency

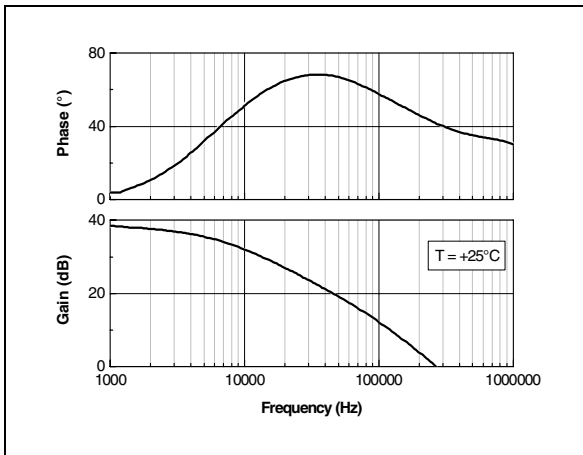

Figure 10. Test circuit for off-state current measurement

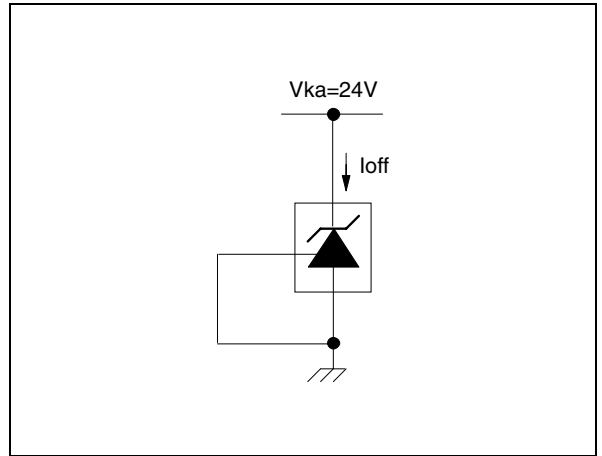

Figure 11. Test circuit for V_K > V_{REF}

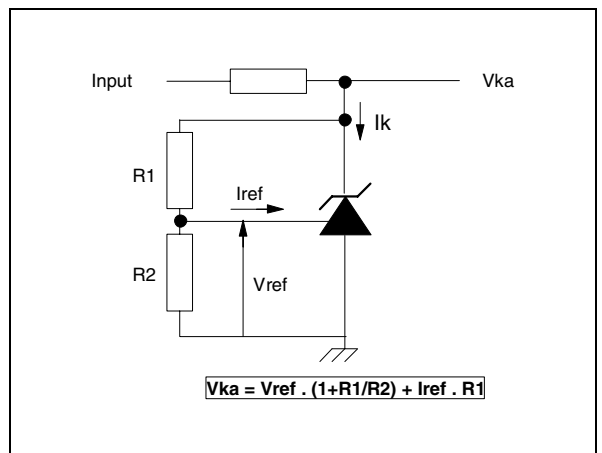

Figure 12. Test circuit for phase and gain measurement

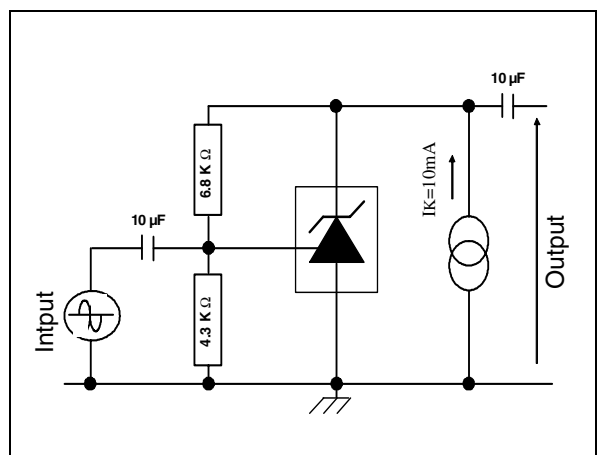

Figure 13. Pulse response at $I_K=1\text{mA}$

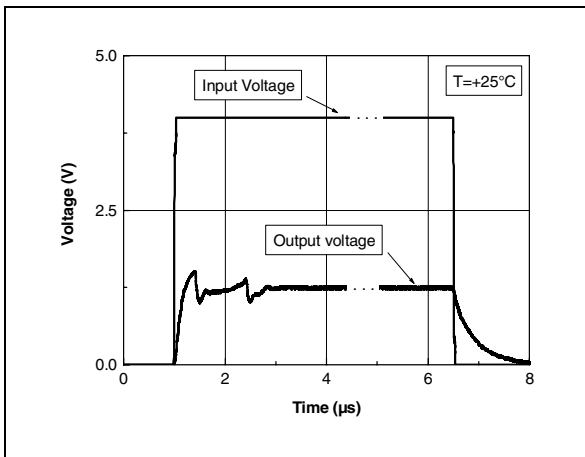

Figure 14. Pulse response at $I_K = 10\text{mA}$

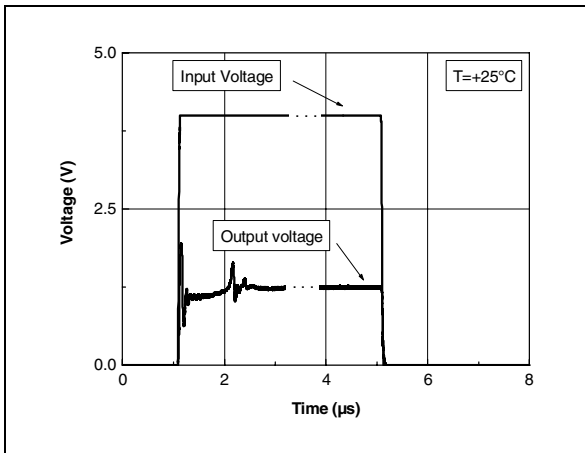

Figure 15. Block diagram

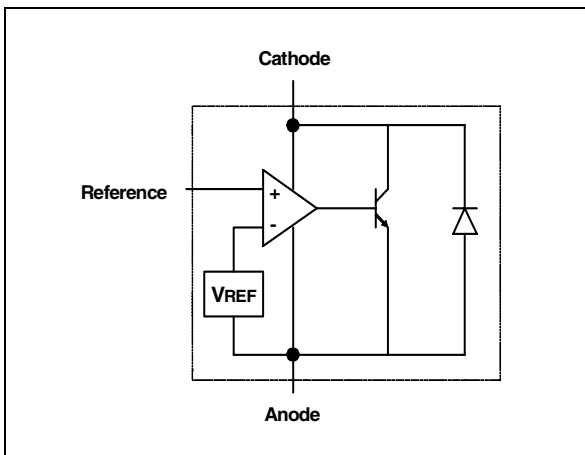

Figure 16. Test circuit for pulse response at $I_K = 1\text{mA}$

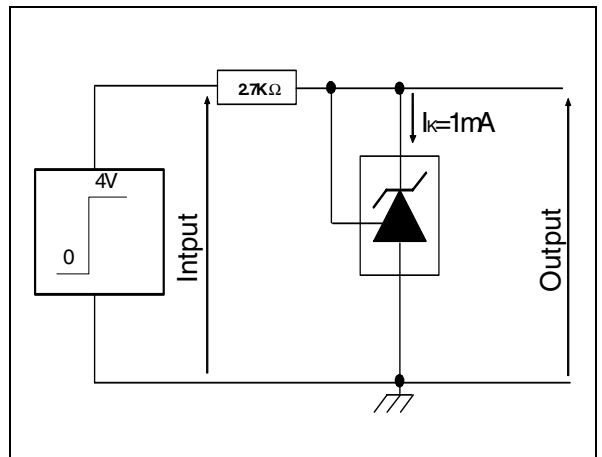

Figure 17. Test circuit for pulse response at $I_K = 10\text{mA}$

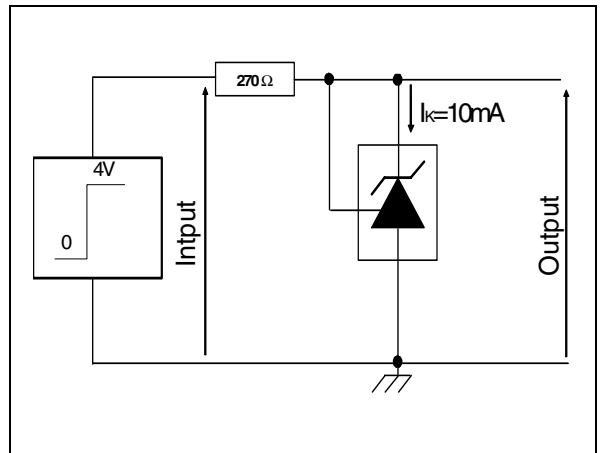
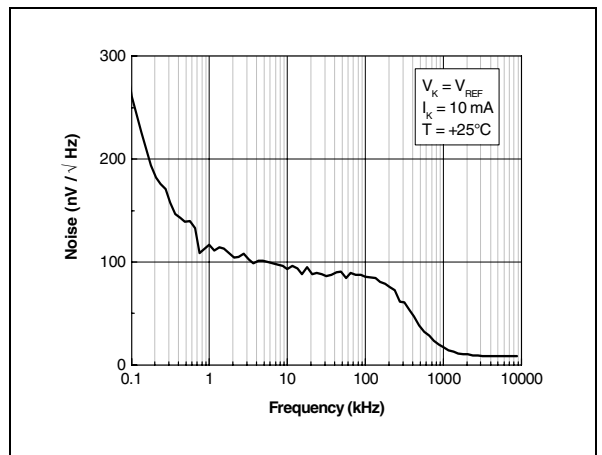
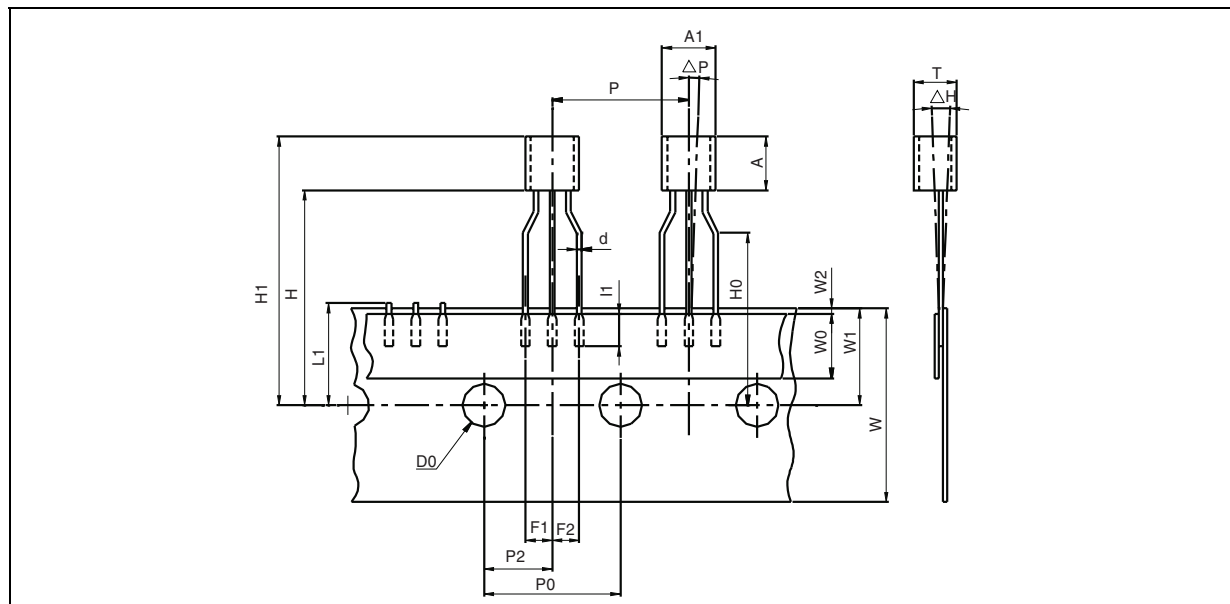

Figure 18. Equivalent input noise vs frequency



3 Package Mechanical Data

3.1 3 Pins - Plastic Package TO-92 (tape & reel)



Dim.	Millimeters			Inches		
	Min.	Typ.	Max.	Min.	Typ.	Max.
AL			5.0			0.197
A			5.0			0.197
T			4.0			0.157
d		0.45			0.018	
I1	2.5			0.098		
P	11.7	12.7	13.7	0.461	0.500	0.539
PO	12.4	12.7	13	0.488	0.500	0.512
P2	5.95	6.35	6.75	0.234	0.250	0.266
F1/F2	2.4	2.5	2.8	0.094	0.098	0.110
Δh	-1	0	1	-0.039	0	0.039
ΔP	-1	0	1	-0.039	0	0.039
W	17.5	18.0	19.0	0.689	0.709	0.748
W0	5.7	6	6.3	0.224	0.236	0.248
W1	8.5	9	9.75	0.335	0.354	0.384
W2			0.5			0.020
H			20			0.787
H0	15.5	16	16.5	0.610	0.630	0.650
H1			25			0.984
DO	3.8	4.0	4.2	0.150	0.157	0.165
L1			11			0.433

3.2 3 Pins - Plastic Package TO-92 (tape ammo pack)

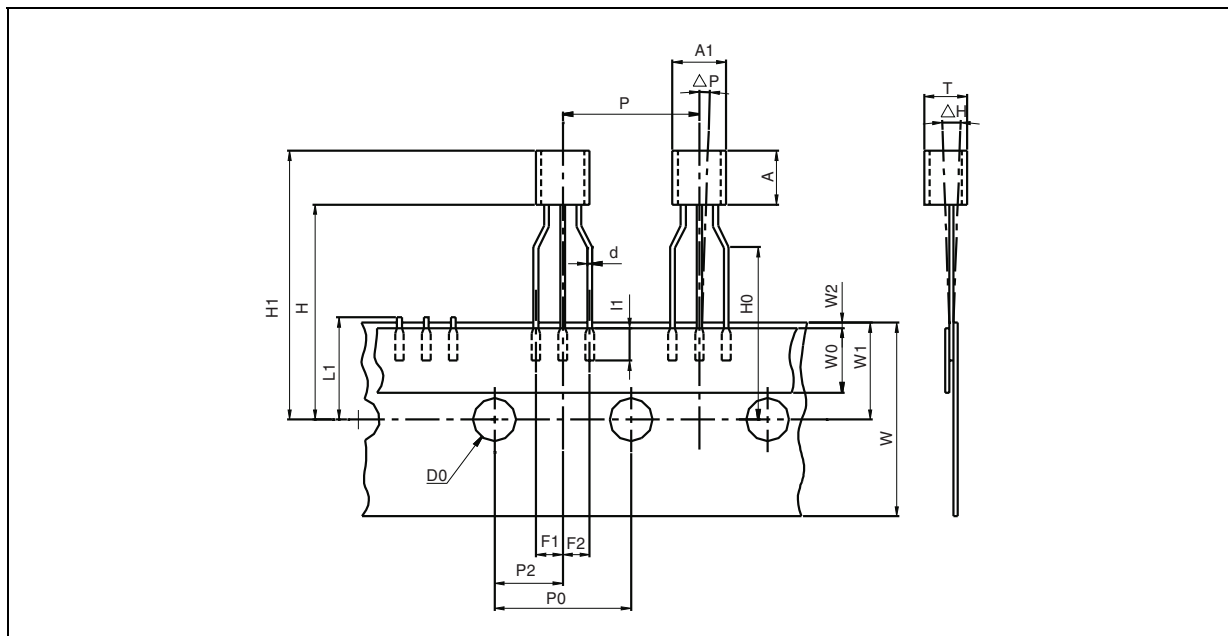

Dim.	Millimeters			Inches		
	Min.	Typ.	Max.	Min.	Typ.	Max.
AL			5.0			0.197
A			5.0			0.197
T			4.0			0.157
d		0.45			0.018	
l1	2.5			0.098		
P	11.7	12.7	13.7	0.461	0.500	0.539
PO	12.4	12.7	13	0.488	0.500	0.512
P2	5.95	6.35	6.75	0.234	0.250	0.266
F1/F2	2.4	2.5	2.8	0.094	0.098	0.110
Δh	-1	0	1	-0.039	0	0.039
ΔP	-1	0	1	-0.039	0	0.039
W	17.5	18.0	19.0	0.689	0.709	0.748
W0	5.7	6	6.3	0.224	0.236	0.248
W1	8.5	9	9.75	0.335	0.354	0.384
W2			0.5			0.020
H			20			0.787
H0	15.5	16	16.5	0.610	0.630	0.650
H1			25			0.984
DO	3.8	4.0	4.2	0.150	0.157	0.165
L1			11			0.433

3.3 3 Pins - Plastic Package TO-92 (bulk)

TO-92 MECHANICA DATA

DIM.	mm.			mils		
	MIN.	TYP.	MAX.	MIN.	TYP.	MAX.
A	4.32		4.95	170.1		194.9
b	0.36		0.51	14.2		20.1
D	4.45		4.95	175.2		194.9
E	3.30		3.94	129.9		155.1
e	2.41		2.67	94.9		105.1
e1	1.14		1.40	44.9		55.1
L	12.7		15.49	500.0		609.8
R	2.16		2.41	85.0		94.9
S1	0.92		1.52	36.2		59.8
W	0.41		0.56	16.1		22.0

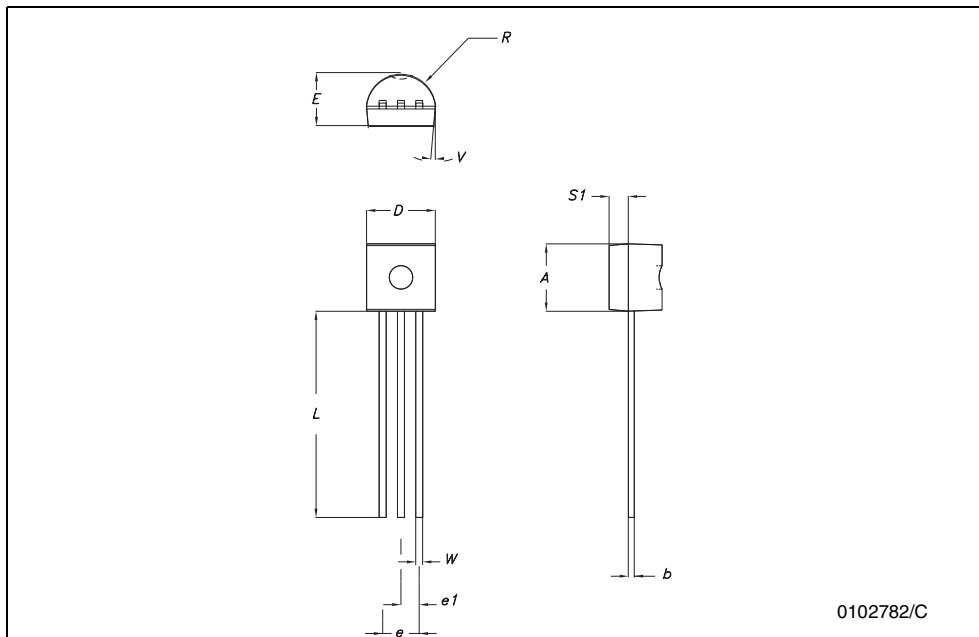

0102782/C

3.4 SOT23-3L Package

SOT23-3L MECHANICAL DATA

DIM.	mm.			mils		
	MIN.	TYP.	MAX.	MIN.	TYP.	MAX.
A	0.890		1.120	35.05		44.12
A1	0.010		0.100	0.39		3.94
A2	0.880	0.950	1.020	34.65	37.41	40.17
b	0.300		0.500	11.81		19.69
C	0.080		0.200	3.15		7.88
D	2.800	2.900	3.040	110.26	114.17	119.72
E	2.100		2.64	82.70		103.96
E1	1.200	1.300	1.400	47.26	51.19	55.13
e		0.950			37.41	
e1		1.900			74.82	
L	0.400		0.600	15.75		23.63
L1		0.540			21.27	
k			8°			8°

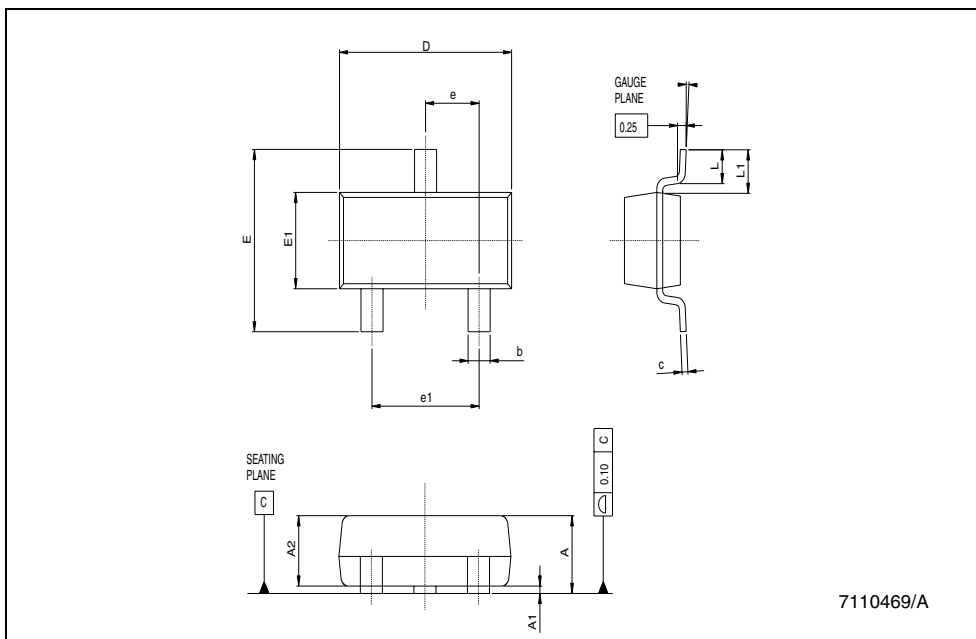

4 Revision History

Date	Revision	Description of Changes
01 Jan. 2004	1	First Release
01 Dec. 2004	2	Specific content changes as follows: <ul style="list-style-type: none"> • CI version added in <i>Table: Order Codes</i> on page 1 • Rthjc information added in <i>Table1: Key parameters and their absolute maximum ratings</i> on page 2 • Test condition added in <i>Table3: Tamb = 25°C (unless otherwise specified)</i> on page 3

Information furnished is believed to be accurate and reliable. However, STMicroelectronics assumes no responsibility for the consequences of use of such information nor for any infringement of patents or other rights of third parties which may result from its use. No license is granted by implication or otherwise under any patent or patent rights of STMicroelectronics. Specifications mentioned in this publication are subject to change without notice. This publication supersedes and replaces all information previously supplied. STMicroelectronics products are not authorized for use as critical components in life support devices or systems without express written approval of STMicroelectronics.

The ST logo is a registered trademark of STMicroelectronics
 All other names are the property of their respective owners

© 2004 STMicroelectronics - All rights reserved

STMicroelectronics group of companies

Australia - Belgium - Brazil - Canada - China - Czech Republic - Finland - France - Germany - Hong Kong - India - Israel - Italy - Japan - Malaysia - Malta - Morocco - Singapore - Spain - Sweden - Switzerland - United Kingdom - United States of America

www.st.com