



Chipsmall Limited consists of a professional team with an average of over 10 year of expertise in the distribution of electronic components. Based in Hongkong, we have already established firm and mutual-benefit business relationships with customers from,Europe,America and south Asia,supplying obsolete and hard-to-find components to meet their specific needs.

With the principle of "Quality Parts,Customers Priority,Honest Operation,and Considerate Service",our business mainly focus on the distribution of electronic components. Line cards we deal with include Microchip,ALPS,ROHM,Xilinx,Pulse,ON,Everlight and Freescale. Main products comprise IC,Modules,Potentiometer,IC Socket,Relay,Connector.Our parts cover such applications as commercial,industrial, and automotives areas.

We are looking forward to setting up business relationship with you and hope to provide you with the best service and solution. Let us make a better world for our industry!



Contact us

Tel: +86-755-8981 8866 Fax: +86-755-8427 6832

Email & Skype: info@chipsmall.com Web: www.chipsmall.com

Address: A1208, Overseas Decoration Building, #122 Zhenhua RD., Futian, Shenzhen, China



1A Ultra Low Dropout Voltage Regulator with Multi-Functions

DESCRIPTION

The TS39104 are 1A ultra low dropout linear voltage regulators that provide low voltage, high current output from an extremely small package. This regulator offers extremely low dropout (typically 400mV at 1A) and very low ground current (typically 12mA at 1A).

The TS39104 are fully protected against over current faults, reversed input polarity, reversed lead insertion, over temperature operation, positive and negative transient voltage spikes, logic level enable control and error flag which signals whenever the output falls out of regulation.

On the TS39104, the enable pin may be tied to Vin if it is not required for enable control.

FEATURES

- Dropout voltage typically 400mV @ Io=1A
- Output Current up to 1A
- Low Ground Current
- Extremely Fast Transient Response
- Reversed Leakage & Reverse Battery Protection
- Current Limit Protection
- Thermal Shutdown Protection
- Compliant to RoHS Directive 2011/65/EU and in accordance to WEEE 2002/96/EC.
- Halogen-free according to IEC 61249-2-21

APPLICATION

- ULDO Linear Regulator for PC add-in Cards
- PowerPC™ Power Supplies
- Battery Powered Equipment
- Consumer and Personal Electronics
- High Efficiency Linear Power Supplies
- SMPS Post Regulator and DC to DC Modules
- High-efficiency Post Regulator for Switching Supply
- Portable Application
- Low-Voltage microcontrollers and Digital Logic

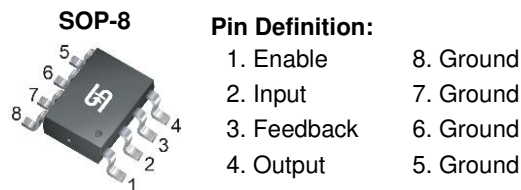

Note: MSL 3 (Moisture Sensitivity Level) per J-STD-020

TYPICAL APPLICATION CIRCUIT

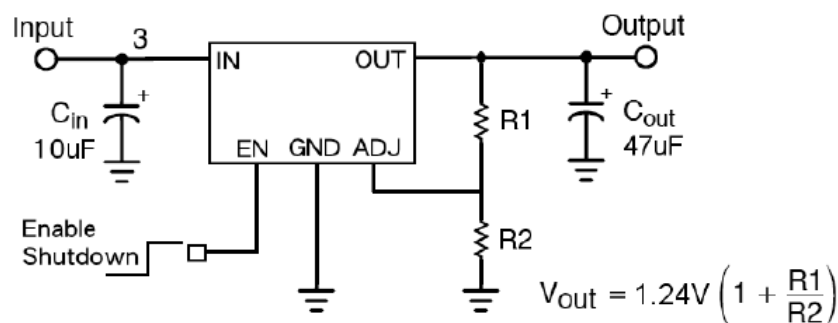

ABSOLUTE MAXIMUM RATINGS (Note 1)			
PARAMETER	SYMBOL	LIMIT	UNIT
Supply Voltage	V_{IN}	-20V ~ +20	V
Enable Voltage	V_{EN}	+20	V
Storage Temperature Range	T_{STG}	-65 ~ +150	°C
Lead Soldering Temperature (260°C)		5	s

RECOMMENDED OPERATING CONDITIONS (Note 3)			
PARAMETER	SYMBOL	CONDITIONS	UNIT
Operation Input Voltage	V_{IN}	+2.25 ~ +16	V
Operation Enable Voltage	V_{EN}	+2.25 ~ +16	V
Power Dissipation (Note 4)	P_D	Internally Limited	W
Operating Junction Temperature Range	T_J	-40 ~ +125	°C
Thermal Resistance Junction to Case	$R_{\theta JC}$	20	°C/W

ELECTRICAL SPECIFICATIONS						
$V_{IN}=V_{OUT}+1V$, $V_{IN}=2.5V$ for fixed reference output voltage, $V_{enable}=2.25V$, $T_A=25^\circ C$, unless otherwise specified						
PARAMETER	CONDITIONS	MIN	TYP	MAX	UNIT	
Reference Output Voltage	$I_L=10mA$	1.215	1.24	1.265	mV	
	$10mA \leq I_L \leq 1.0A$, $2.5V \leq V_{IN} \leq 16V$	1.203		1.277		
Line Regulation	$I_L=10mA$, $V_o+1V \leq V_{IN} \leq 16V$	--	0.05	0.5	%	
Load Regulation	$V_{IN}=V_{out}+1V$, $8mA \leq I_L \leq 300mA$	--	0.05	0.1	%	
	$V_{IN}=V_{out}+1V$, $10mA \leq I_L \leq 1A$	--	0.2	1.0		
Output Voltage Temp. Coefficient		--	40	100	ppm/°C	
Dropout Voltage (Note 5)	$\Delta V_{OUT} = -1\%$	$I_L=100mA$	--	100	250	mV
		$I_L=500mA$	--	275	350	
		$I_L=1A$	--	400	630	
Quiescent Current (Note 6)	$V_{IN}=V_{OUT}+1V$	$I_L=100mA$	--	0.7	2	mA
		$I_L=500mA$	--	4	6	
		$I_L=1A$	--	12	20	
Current Limit	$V_{OUT}=0$, $V_{IN}=V_{OUT}+1V$	--	1.8	--	A	
Adjust Pin Bias Current		--	40	120	nA	
Reference Voltage Temp. Coefficient	(Note 8)	--	20	--	ppm/°C	
Adjust Pin Bias Current Temp. Coefficient		--	0.1	--	nA/°C	
Enable Input						
Input Logic Voltage	Low (OFF)	--	--	0.8	V	
	High (ON)	2.25	--	--		
Enable Pin Input Current	$V_{EN}=2.25V$	--	--	75	μA	
	$V_{EN}=0.8V$	--	--	4		

ELECTRICAL SPECIFICATIONS (Continue)

Note:

1. Absolute Maximum Rating is limits beyond which damage to the device may occur. For guaranteed specifications and test conditions see the Electrical Characteristics.
2. The device is not guaranteed to operate outside its operating rating.
3. Devices are ESD sensitive. Handling precautions recommended.
4. The maximum allowable power dissipation is a function of the maximum junction temperature, T_J , the junction to ambient thermal resistance, $R_{\Theta JA}$, and the ambient temperature, T_A . Exceeding the maximum allowable power dissipation will cause excessive die temperature, and the regulator will go into thermal shutdown. The effective value of $R_{\Theta JA}$ can be reduced by using a heat sink, $PD_{(max)} = (T_{J(max)} - T_A) / R_{\Theta JA}$
5. Dropout voltage is defined as the input to output differential at which the output voltage drops -1% below its nominal value measured at 1V differential.
6. Ground pin current is the regulator quiescent current. The total current drawn from the source is the sum of the ground pin current and output load current, $I_{GND} = I_{IN} - I_{OUT}$ for fix output voltage, , $I_{GND} = I_{IN} - I_{OUT} + 10mA$ for fix reference output voltage in full load regulation.
7. $V_{REF} \leq V_{OUT} \leq (V_{IN} - 1V)$, $2.25V \leq V_{IN} \leq 16V$, $10mA \leq I_L \leq 1A$.
8. Output voltage temperature coefficient is ΔV_{OUT} (worse cast) / $(T_{J(max)} - T_{J(MIN)})$ where is $T_{J(max)} + 125^\circ C$ and $T_{J(MIN)}$ is $0^\circ C$.
9. For adjustable device and fixed device with $V_{OUT} > 2.25V$

ORDERING INFORMATION

PART NO.	PACKAGE	PACKING
TS39104CS RLG	SOP-8	2,500pcs / 13"Reel

BLOCK DIAGRAM

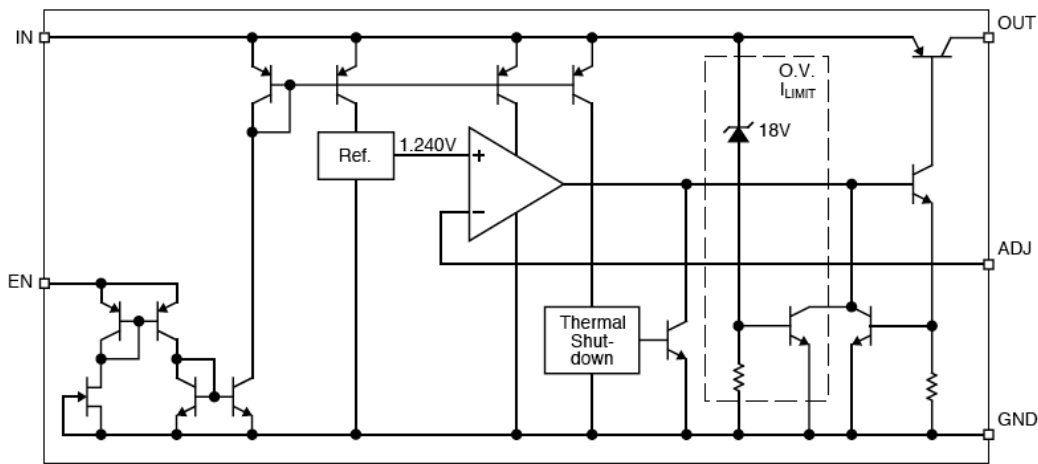

PIN DESCRIPTION

PIN NO.	NAME	FUNCTION
1	Enable	TTL/COMS compatible input. Logic high is enable; logic low or open is shutdown
2	Input	Unregulated input: +16V maximum supply
3	Adjustable	Adjustable input: Feedback input. Connect to resistive voltage-divider network.
4	Output	Regulator output
5,6,7,8	Ground	Ground pin

APPLICATION INFORMATION

The TS39104 is a high performance with low dropout voltage regulator suitable for moderate to high current and voltage regulator application. Its 630mV dropout voltage at full load and over temperature makes it especially valuable in battery power systems and as high efficiency noise filters in post regulator applications. Unlike normal NPN transistor design, where the base to emitter voltage drop and collector to emitter saturation voltage limit the minimum dropout voltage, dropout performance of the PNP output of these devices is limited only by low V_{CE} saturation voltage.

The TS39104 is fully protected from damage due to fault conditions. Linear current limiting is provided. Output current during overload conditions is constant. Thermal shutdown the device when the die temperature exceeds the maximum safe operating temperature. Transient protection allows device survival even when the input voltage spikes above and below nominal. The output structure of these regulators allows voltages in excess of the desired output voltage to be applied without reverse current flow

Input Capacitor Requirement

An input capacitor of 1 μ F or greater is recommended when the device is more than 4" away from the bulk AC supply capacitance or when the supply is a battery. Small, surface mount, ceramic chip capacitors can be used for bypassing. Larger values will help to improve ripple rejection by bypassing the input to the regulator, further improving the integrity of the output voltage.

Minimum Load Current

The TS39104 is specified between finite loads. If the output current is too small leakage currents dominate and the output voltage rises. A 10mA minimum load current is necessary for proper regulation.

APPLICATION INFORMATION (Continue)

Output Capacitor Requirement

The TS39104 requires an output capacitor to maintain stability and improve transient response is necessary. The value of this capacitor is dependent upon the output current, lower currents allow smaller capacitors. TS39104 output capacitor selection is dependent upon the ESR of the output capacitor to maintain stability. When the output capacitor is 10 μ F or greater, the output capacitor should have an ESR less than 2 Ω . This will improve transient response as well as promote stability. Ultra low ESR capacitors (<100m Ω), such as ceramic chip capacitors, may promote instability. These very low ESR levels may cause an oscillation and/or under damped transient response. A low ESR solid tantalum capacitor works extremely well and provides good transient response and stability over temperature aluminum electrolytes can also be used, as long as the ESR of the capacitor is <2 Ω . The value of the output capacitor can be increased without limit. Higher capacitance values help to improve transient response and ripple rejection and reduce output noise.

Adjustable Regulator Output Design

The adjustable regulator is allow to programming the output voltage anywhere between 1.25 and the 16V maximum operating rating of the family.

Two resistors are used. Resistors can be quite large up to 1M Ω , because of the very high input impedance and low bias current of the sense comparator, the resistor values are calculated by:

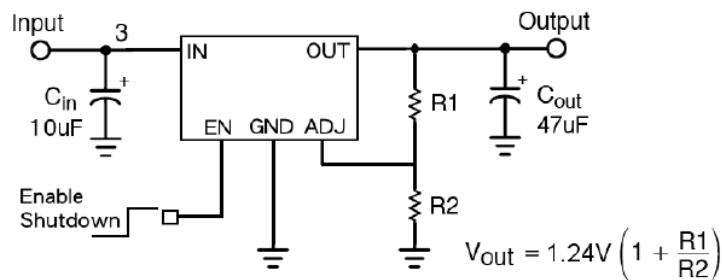

Where V_{OUT} is the desired output voltage. Above application circuit shows component definition. Applications with widely varying load currents may scale the resistors to draw the minimum load current required for proper operation.

Enable Input

TS39104 versions feature an active-high enable (EN) input that allows ON/OFF control of the regulator. Current drain reduces to “zero” when the device is shutdown, with only micro-amperes of leakage current. The EN input has TTL/CMOS compatible thresholds for simple interfacing with logic interfacing. EN may be directly tied to V_{IN} and pulled up to the maximum supply voltage.

Transient Response and 3.3V to 2.5V or 2.5V to 1.8V Conversion

TS39104 has excellent transient response to variations in input voltage and load current. The device has been designed to respond quickly to load current variations and input voltage variations. Large output capacitors are not required to obtain this performance. A standard 10 μ F output capacitor, preferably tantalum, is all that is required. Larger values help to improve performance even further. By virtue of its low dropout voltage, this device does not saturate into dropout as readily as similar NPN base designs. When converting from 3.3V to 2.5V or 2.5V to 1.8V, the NPN based regulators are already operating in dropout, with typical dropout requirements of 1.2V or greater,. To convert down to 2.5V or 1.8V without operating in dropout, NPN based regulators require an input voltage of 3.7V at the very least. The TS39104 regulator will provide excellent performance with an input as low as 3.0V or 2.5V respectively. This gives the PNP based regulators a distinct advantage over older, NPN based linear regulators.

APPLICATION INFORMATION (Continue)

Power SOP-8 Thermal Characteristic

TS39104 series performance is its power SOP-8 package featuring half the thermal resistance of a standard SOP-8 package. Lower thermal resistance means more output current or higher input voltage for a standard SOP-8 package. Lower thermal resistance means more output current or higher input voltage for a given package size. Lower thermal resistance is achieved by connect the four ground pins with the die attached pad to create a single piece electrical and thermal conductor. This concept have been used by MOSFET production for years, proving very reliable and cost effective for the user. As above thermal resistance figure. Thermal resistance consists of two main elements, $R_{\theta JC}$ (junction to case) and $R_{\theta CA}$ (case to ambient). Using the power SOP-8 reduces $R_{\theta CA}$, the total thermal resistance, $R_{\theta JA}$ (junction to ambient) is the limiting factor in calculating the maximum power dissipation capability of the device. Typically, the power SOP-8 have a $R_{\theta JC}$ of 20°C/W dramatically , this is significantly lower than the standard SOP-8 which is typically 75°C/W. $R_{\theta CA}$ is reduced because pin 5~8 can be soldered directly to a ground plane which significantly reduces the case to sink and sink to ambient thermal resistance.

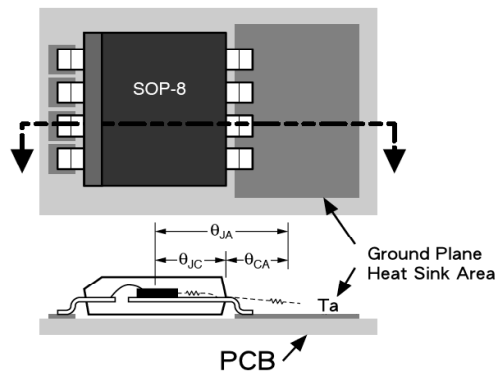

Thermal Resistance

Power Dissipation

From under curves, the minimum area of copper necessary for the par to operate safely can be determined. The maximum allowable temperature rise must be calculated to determine operation along which curve.

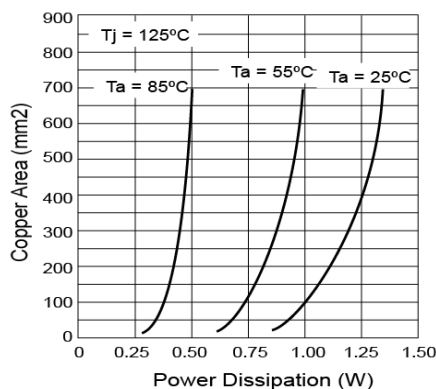

APPLICATION INFORMATION (Continue)

Copper area lay out information

Determine the power dissipation requirements for the design along with the maximum ambient temperature at which the device will be operated. Refer to power dissipation with copper area curve, which shows safe operating curves for three different ambient temperatures with 25°C, 50°C, 85°C. From these curves, the minimum amount of copper can be determined by knowing the maximum power dissipation required.

$$P_D = (V_{IN} - V_{OUT}) * I_{OUT} + V_{IN} * I_{GND}$$

If we used a 5.0V output device and a 6V input at an output current of 350mA, then the power dissipation is as follows:

$$P_D = (6.0V - 5.0V) * 350mA + 5V * 4mA$$

$$P_D = 350mW + 20mW$$

$$P_D = 370mW$$

If the maximum ambient temperature is 85°C and the power dissipation is as above 375mW, the curve is shows that the required area of copper is 80mm².

PACKAGE OUTLINE DIMENSIONS (Unit: Millimeters)

SOP-8

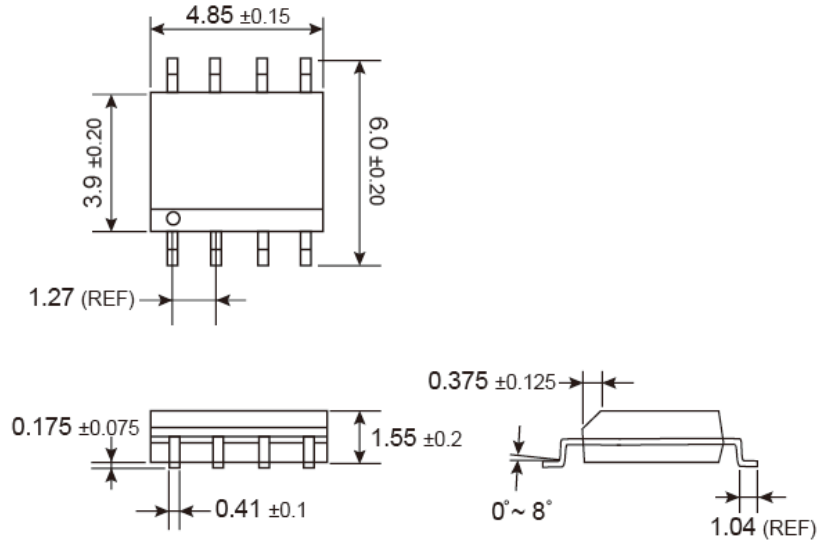

SUGGESTED PAD LAYOUT (Unit: Millimeters)

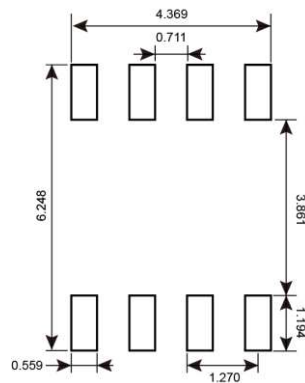

MARKING DIAGRAM

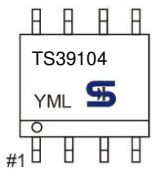

- Y** = Year Code
- M** = Month Code for Halogen Free Product
 - O** =Jan
 - P** =Feb
 - Q** =Mar
 - R** =Apr
 - S** =May
 - T** =Jun
 - U** =Jul
 - V** =Aug
 - W** =Sep
 - X** =Oct
 - Y** =Nov
 - Z** =Dec
- L** = Lot Code (1~9, A~Z)

Notice

Specifications of the products displayed herein are subject to change without notice. TSC or anyone on its behalf, assumes no responsibility or liability for any errors or inaccuracies.

Information contained herein is intended to provide a product description only. No license, express or implied, to any intellectual property rights is granted by this document. Except as provided in TSC's terms and conditions of sale for such products, TSC assumes no liability whatsoever, and disclaims any express or implied warranty, relating to sale and/or use of TSC products including liability or warranties relating to fitness for a particular purpose, merchantability, or infringement of any patent, copyright, or other intellectual property right.

The products shown herein are not designed for use in medical, life-saving, or life-sustaining applications. Customers using or selling these products for use in such applications do so at their own risk and agree to fully indemnify TSC for any damages resulting from such improper use or sale.