



Chipsmall Limited consists of a professional team with an average of over 10 year of expertise in the distribution of electronic components. Based in Hongkong, we have already established firm and mutual-benefit business relationships with customers from,Europe,America and south Asia,supplying obsolete and hard-to-find components to meet their specific needs.

With the principle of “Quality Parts,Customers Priority,Honest Operation,and Considerate Service”,our business mainly focus on the distribution of electronic components. Line cards we deal with include Microchip,ALPS,ROHM,Xilinx,Pulse,ON,Everlight and Freescale. Main products comprise IC,Modules,Potentiometer,IC Socket,Relay,Connector.Our parts cover such applications as commercial,industrial, and automotives areas.

We are looking forward to setting up business relationship with you and hope to provide you with the best service and solution. Let us make a better world for our industry!



## Contact us

Tel: +86-755-8981 8866 Fax: +86-755-8427 6832

Email & Skype: info@chipsmall.com Web: www.chipsmall.com

Address: A1208, Overseas Decoration Building, #122 Zhenhua RD., Futian, Shenzhen, China



## Ultra Low Quiescent Current 5V/150mA Fixed-Voltage Ultra Low LDO

### DESCRIPTION

The TS4264GCW50 is a monolithic integrated low-drop fixed voltage regulator which can supply loads up to 150mA. It is functional compatible to the TS4264CW50 but has a reduced quiescent current of typ. 40µA. The TS4264GCW50 is especially designed for all applications which require very low quiescent currents. This ULDO is designed to supply microprocessor systems under the severe condition of automotive applications and is therefore equipped with additional protection against overload, short-circuit and over temperature. Of course the TS4264GCW50 can be used in all other applications, wherever a stabilized voltage is required.

An input voltage in the range of 5.5V ~ 45V is regulated to  $V_{OUT} = 5V$  with an accuracy of  $\pm 3\%$ . An accuracy of  $\pm 2\%$  is kept for a load current range up to 50mA. The device operates in the temperature range of  $T_J = -40 \sim 150^\circ C$ .

### FEATURES

- Fixed Output Voltage 5V
- Output Voltage Tolerance  $\pm 3\%$
- 150mA Current Capability
- Ultra Low Quiescent Current 40µA (Typ.)
- Over Temperature Protection
- Short-Circuit Proof
- Reverse Polarity Proof
- Wide Temperature Polarity Range
- Suitable for use in Automotive Electronics

### APPLICATION

- Control module
- Body and Chassis
- Powertrain



### Pin Definition:

1. Input
2. Ground
3. Output

**Notes:** Moisture sensitivity level: level 3. Per J-STD-020

### TYPICAL APPLICATION CIRCUIT

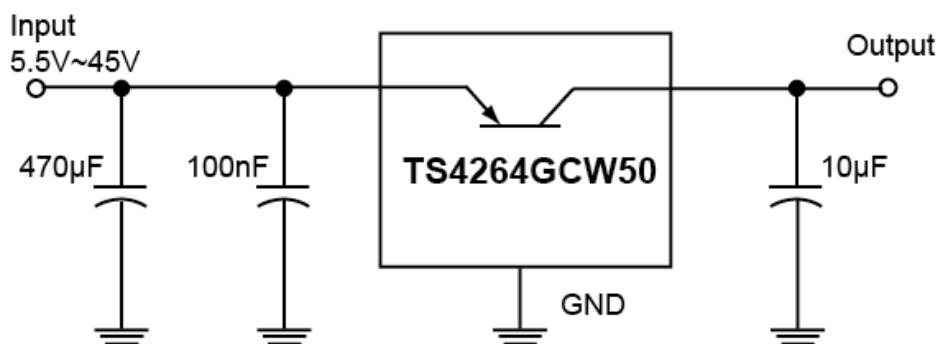

**ABSOLUTE MAXIMUM RATINGS**

PARAMETER	SYMBOL	LIMIT	UNIT
Input Voltage	$V_{IN}$	-42 ~ 45	V
Input Voltage (Operating Range)	$V_{IN(OPR)}$	5.5 ~ 45	V
Input Current	$I_{IN}$	Internal Limited	
Output Voltage	$V_{OUT}$	-0.3 ~ 32	V
Output Current	$I_{OUT}$	Internal Limited	
Ground Current	$I_{GND(MIN)}$	50	mA
Junction Temperature	$T_J$	150	°C
Junction Temperature (Operating Range)	$T_{J(OPR)}$	-40 ~ +150	°C
Storage Temperature	$T_{STG}$	-50 ~ +150	°C

**THERMAL PERFORMANCE** (Note 1)

PARAMETER	SYMBOL	LIMIT	UNIT
Thermal Resistance from Junction to Pin	$R_{\theta JP}$	17	°C/W
Thermal Resistance from Junction to Ambient	$R_{\theta JA}$	80	°C/W

**ELECTRICAL SPECIFICATIONS** ( $V_{IN}=13.5V$ ,  $-40 \leq T_J \leq +150$ , unless otherwise specified)

PARAMETER	CONDITIONS	MIN	TYP	MAX	UNIT
Output Voltage	$6V \leq V_{IN} \leq 21V$ , $5mA \leq I_O \leq 100mA$	4.85	5.00	5.15	V
Output Voltage	$6V \leq V_{IN} \leq 16V$ , $5mA \leq I_O \leq 50mA$	4.90	5.00	5.10	V
Output Current Limit		150	200	500	mA
Current Consumption	$I_O = 100\mu A$ , $T_J \leq 85^\circ C$	--	40	60	$\mu A$
	$I_O = 100\mu A$		40	70	
	$I_O = 50mA$		1.7	4	mA
Dropout Voltage (Note 2)	$I_O = 100mA$	--	0.22	0.5	V
Load Regulation	$5mA \leq I_O \leq 100mA$ , $V_{IN} = 13.5V$	--	50	90	mV
Line Regulation	$6V \leq V_{IN} \leq 28V$ , $I_O = 1mA$	--	5	30	mV
Ripple Rejection	$F = 100Hz$ , $V_R = 0.5V_{PP}$	--	68	--	dB
Output Capacitor	$ESR \leq 4\Omega @ 10kHz$	10	--	--	$\mu F$

**Note:**

1. Measured to pin 2 (tab)
2. Dropout voltage =  $V_{IN} - V_{OUT}$   
(Measured where  $V_{OUT}$  has dropped 100mV from the nominal value obtained at  $V_{IN} = 13.5V$ )



## ORDERING INFORMATION

PART NO.	PACKAGE	PACKING
TS4264GCW50 RPG	SOT-223	2,500pcs / 13" Reel

**Note:**

- Compliant to RoHS Directive 2011/65/EU and in accordance to WEEE 2002/96/EC.
- Halogen-free according to IEC 61249-2-21 definition.

## BLOCK DIAGRAM

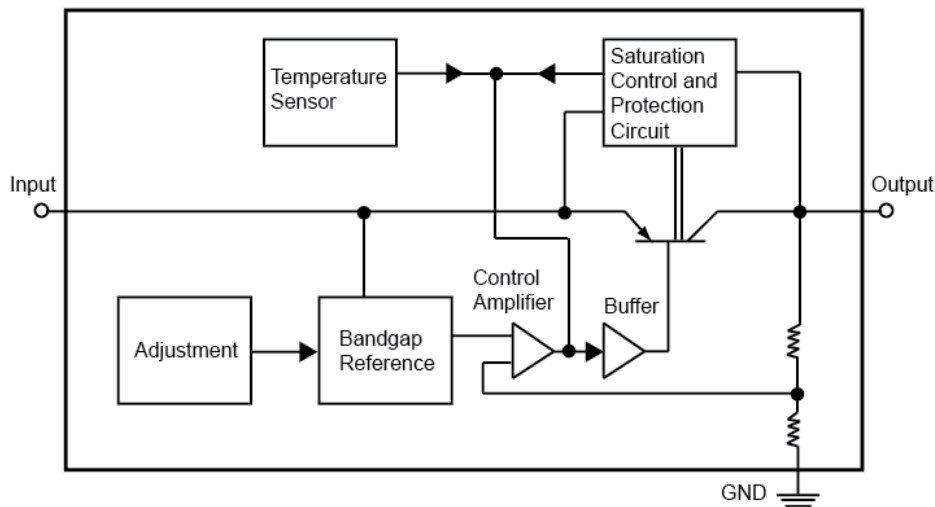

## PIN DESCRIPTION

PIN NO.	NAME	FUNCTION
1	Input	Block to ground directly on IC with ceramic capacitor
2	Ground	Ground
3	Output	Block to ground with 10 $\mu$ F capacitor, ESR < 4 $\Omega$

## APPLICATION INFORMATION

In the TS4264GCW50 the output voltage is divided and compared to an internal reference of 2.5V typical. The regulation loop controls the output to achieve an output voltage of 5V with an accuracy of  $\pm 3\%$  at an input voltage range of 5.5V~45V.

### Dimensioning Information on External Components

The input capacitor  $C_{IN}$  is necessary for compensating line influences. Using a resistor of approx. 1 $\Omega$  in series with  $C_{IN}$ , the oscillating of input inductivity and input capacitance can be clamped. The output capacitor  $C_{OUT}$  is necessary for the stability of the regulating circuit. Stability is guaranteed at values  $C_{OUT} \geq 10\mu F$  and an  $ESR \leq 4\Omega$  within the operating temperature range.

The application circuit shows additional electrolytic input capacitor of 470 $\mu F$  is added in order to buffer supply line influences. This capacitor is recommended, if the device is sourced via long supply lines of several meters.

The TS4264GCW50 can supply up to 150mA. However for protection for high input voltage above 25V, the output current is reduced (SOA protection).

**APPLICATION INFORMATION (CONTINUE)****Circuit Description**

The control amplifier compares a reference voltage, which is kept highly precise by resistance adjustment, to a voltage that is proportional to the output voltage and drives the base of the series transistor via a buffer. Saturation control, working as a function of load current, prevents any over-saturation of the power element. The IC is additionally protected against overload, over temperature and reverse polarity

**PACKAGE OUTLINE DIMENSIONS** (Unit: Millimeters)

**SOT-223**

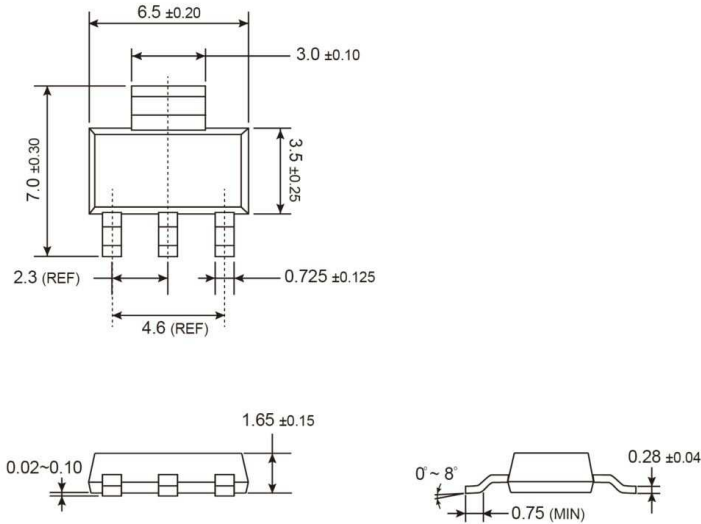

**SUGGESTED PAD LAYOUT** (Unit: Millimeters)

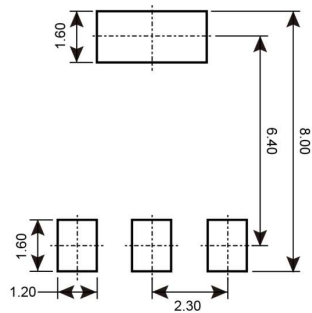

**MARKING DIAGRAM**

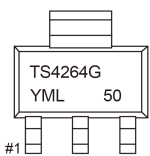

- Y** = Year Code
- M** = Month Code for Halogen Free Product
  - O** =Jan    **P** =Feb    **Q** =Mar    **R** =Apr
  - S** =May    **T** =Jun    **U** =Jul    **V** =Aug
  - W** =Sep    **X** =Oct    **Y** =Nov    **Z** =Dec
- L** = Lot Code (1~9, A~Z)
- 50** = 5V fixed Output Voltage

## Notice

Specifications of the products displayed herein are subject to change without notice. TSC or anyone on its behalf, assumes no responsibility or liability for any errors or inaccuracies.

Information contained herein is intended to provide a product description only. No license, express or implied, to any intellectual property rights is granted by this document. Except as provided in TSC's terms and conditions of sale for such products, TSC assumes no liability whatsoever, and disclaims any express or implied warranty, relating to sale and/or use of TSC products including liability or warranties relating to fitness for a particular purpose, merchantability, or infringement of any patent, copyright, or other intellectual property right.

The products shown herein are not designed for use in medical, life-saving, or life-sustaining applications. Customers using or selling these products for use in such applications do so at their own risk and agree to fully indemnify TSC for any damages resulting from such improper use or sale.