



Chipsmall Limited consists of a professional team with an average of over 10 year of expertise in the distribution of electronic components. Based in Hongkong, we have already established firm and mutual-benefit business relationships with customers from,Europe,America and south Asia,supplying obsolete and hard-to-find components to meet their specific needs.

With the principle of “Quality Parts,Customers Priority,Honest Operation,and Considerate Service”,our business mainly focus on the distribution of electronic components. Line cards we deal with include Microchip,ALPS,ROHM,Xilinx,Pulse,ON,Everlight and Freescale. Main products comprise IC,Modules,Potentiometer,IC Socket,Relay,Connector.Our parts cover such applications as commercial,industrial, and automotives areas.

We are looking forward to setting up business relationship with you and hope to provide you with the best service and solution. Let us make a better world for our industry!



Contact us

Tel: +86-755-8981 8866 Fax: +86-755-8427 6832

Email & Skype: info@chipsmall.com Web: www.chipsmall.com

Address: A1208, Overseas Decoration Building, #122 Zhenhua RD., Futian, Shenzhen, China



Low voltage adjustable shunt reference

Datasheet - production data

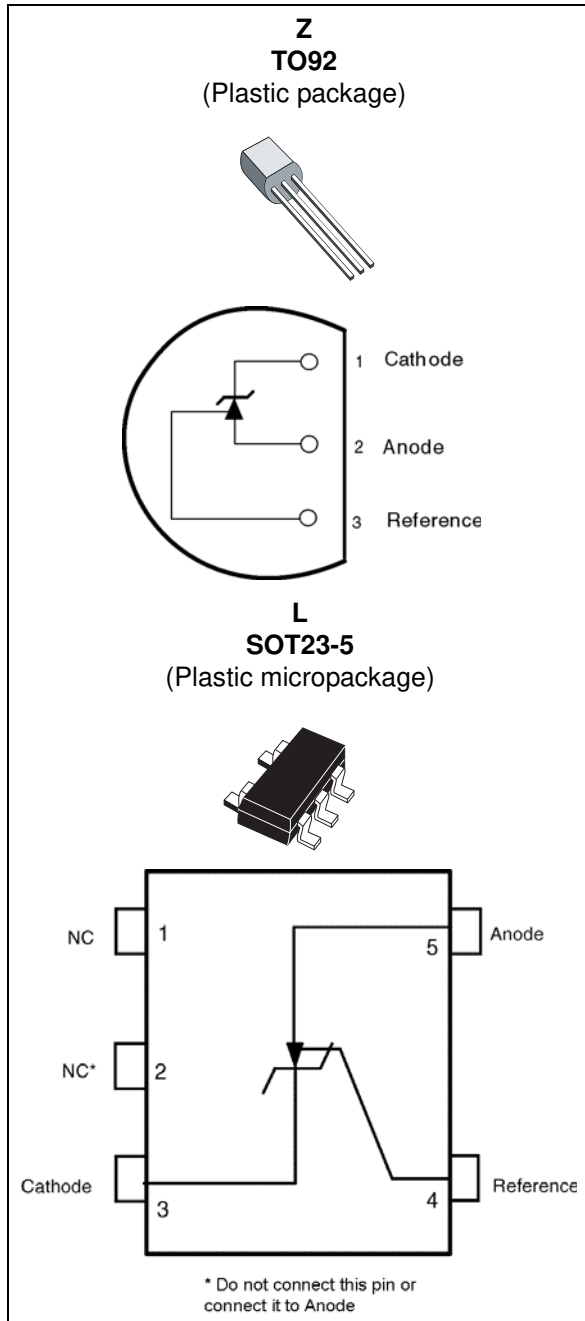

Features

- Low voltage operation: 1.24 V to 6 V
- 2 %, 1 % and 0.5 % voltage precision
- Wide operating range cathode current: 60 μ A to 30 mA
- Low output impedance: 0.2 Ω
- Typically stable for any capacitive loads
- ESD protection:
 - Human body model: 2 kV
 - Machine model: 200 V
- 100 ppm/ $^{\circ}$ C temperature coefficient
- Automotive grade version available

Description

The TS431 is a low-voltage, three-terminal, programmable shunt voltage reference. The output voltage can be set to any value between V_{ref} (1.24 V) and 6 V using two external resistors. The TS431 is able to operate at a lower voltage (1.24 V) and lower cathode current than the widely-used TL431 and TL1431 shunt voltage reference. When driving an optocoupler, the TS431 is particularly suitable for regulating 3.3 V switching power supplies.

1 Absolute maximum ratings and operating conditions

Table 1. Absolute maximum ratings

Symbol	Parameter	Value	Unit
V_{KA}	Cathode to anode voltage	10	V
I_k	Continuous cathode current range	-20 to +40	mA
I_{ref}	Reference input current range	-0.05 to +3	mA
P_d	Power dissipation ⁽¹⁾ TO92 package SOT23-5 package	625 500	mW
T_{stg}	Storage temperature range	-65 to +150	°C

1. $T_{junction} = 150\text{ °C}$, $T_{amb} = 25\text{ °C}$ with
 $R_{thJA} = 200\text{ °C/W}$ for TO92 package and
 $R_{thJA} = 250\text{ °C/W}$ for SOT23-5L package

Table 2. Operating conditions

Symbol	Parameter	Value	Unit
V_{KA}	Cathode to anode voltage	1.24 to 6	V
I_k	Cathode current ⁽¹⁾	0.06 to 30	mA
T_{oper}	Operating free air temperature range	-40 to +125	°C

1. Please refer to [Section 3: Application information](#) for more details.

2 Electrical characteristics

Table 3. $T_{amb} = 25^{\circ}\text{C}$ (unless otherwise specified)

Symbol	Parameter	Test conditions	Min.	Typ.	Max.	Unit
V_{ref}	Output voltage $V_{KA} = V_{ref} @ I_k = 100\mu\text{A}$	TS431 TS431A TS431B	1.215 1.228 1.234	1.240	1.265 1.252 1.246	V
ΔV_{ref}	Output voltage change ^{(1) (2)} $I_k = 100\mu\text{A}, V_{KA} = V_{ref}$	$0 < T_{amb} < +70^{\circ}\text{C}$ $-40 < T_{amb} < +85^{\circ}\text{C}$ $-40 < T_{amb} < +105^{\circ}\text{C}$ $-40 < T_{amb} < +125^{\circ}\text{C}$			9 16 18 21	mV
$\frac{ \Delta V_{ref} }{\Delta V_{ka}}$	Ratio of change in reference input voltage to change in cathode to anode voltage	$I_k = 10\text{mA}$ $V_{KA} = 6\text{V to } V_{ref}$		1.8	2.7	mV/V
I_{ref}	Reference input current	$I_k = 10\text{mA}$		70	160	nA
ΔI_{ref}	Reference input current deviation over temperature range	$I_k=10\text{mA}, R_1=10\text{k}\Omega, R_2=\infty$ $-40 < T_{amb} < +85^{\circ}\text{C}$ $-40 < T_{amb} < +125^{\circ}\text{C}$		70 90	160 240	nA
I_{min}	Minimum cathode current for regulation	$V_{KA} = V_{ref}$		40	60	μA
I_{off}	Off-state cathode current	$V_{KA} = 6\text{V}, V_{ref} = 0$		0.001	0.1	μA
R_{KA}	Static impedance	$V_{KA} = V_{ref}, I_k = 0.1 \text{ to } 15\text{mA}$		0.2	0.4	Ω

- Limits are 100% production tested at 25°C. Behavior at the temperature range limits is guaranteed through correlation and by design.
- See definition below.

2.1 Definition of output voltage change over temperature range

ΔV_{ref} is defined as the difference between the maximum and minimum values obtained over the full temperature range.

$$\Delta V_{ref} = V_{ref \text{ max}} - V_{ref \text{ min}}$$

Figure 1. Output voltage change over temperature range

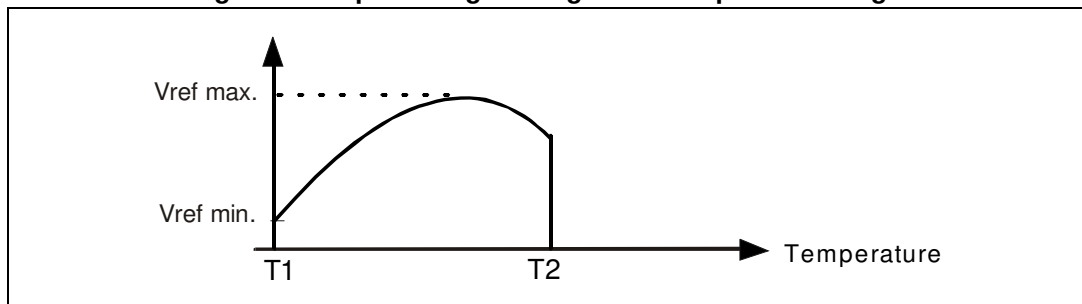

Figure 2. Reference voltage vs. temperature

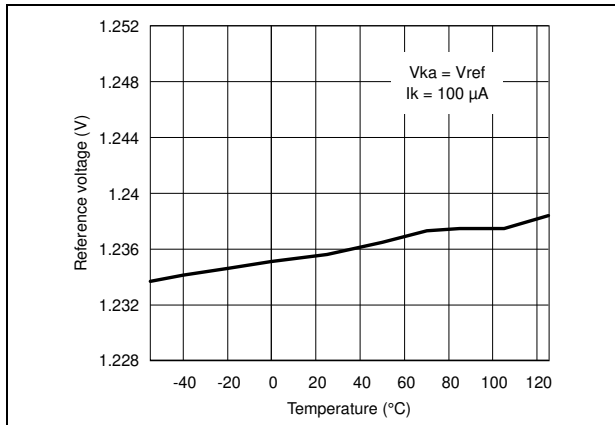

Figure 3. Test circuit for $V_{KA} = V_{ref}$

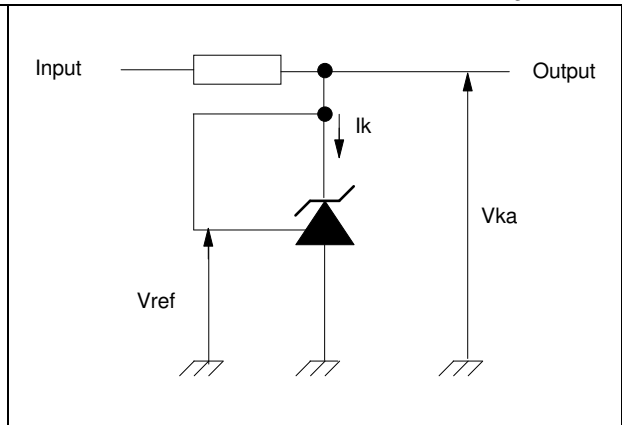

Figure 4. Cathode voltage vs. cathode current

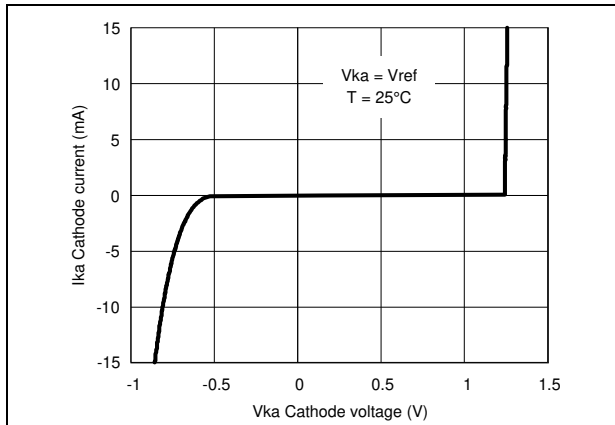

Figure 5. Cathode voltage vs. cathode current

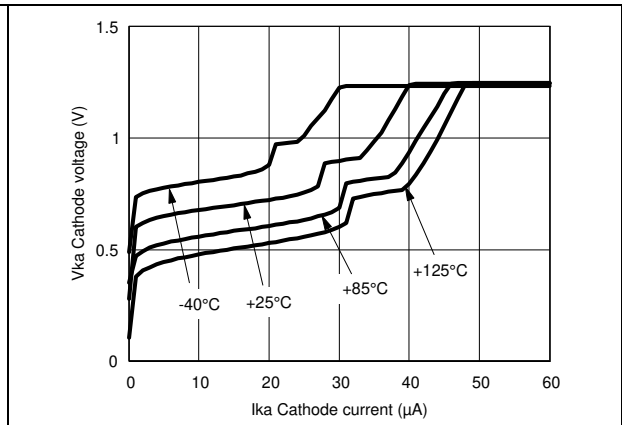

Figure 6. Reference input current vs. temperature

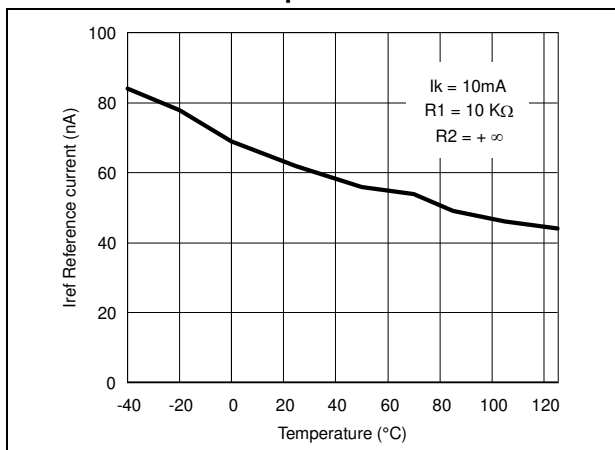

Figure 7. Static impedance vs. temperature

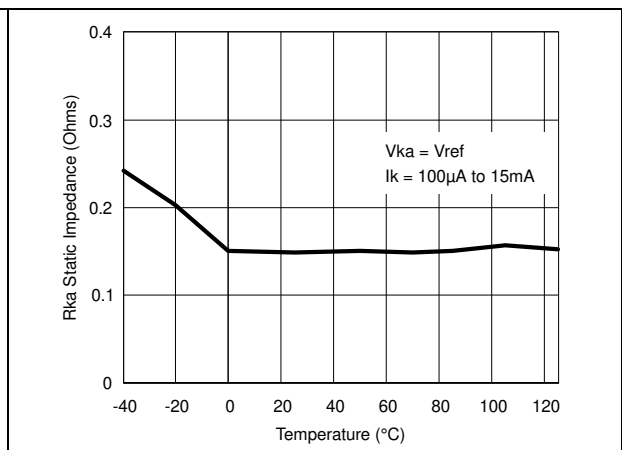

Figure 8. Off-state current vs. temperature

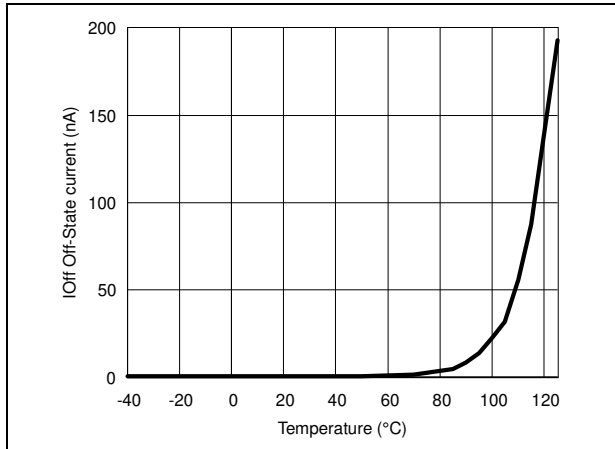

Figure 9. Test circuit for off-state current measurement

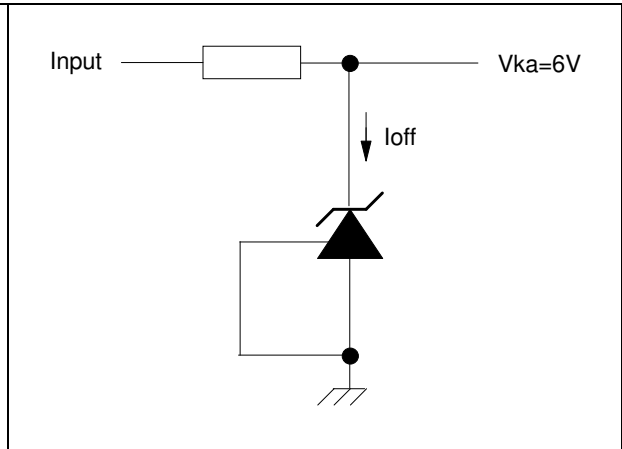

Figure 10. Ratio of change in reference input voltage to change in V_{KA} voltage vs. temperature

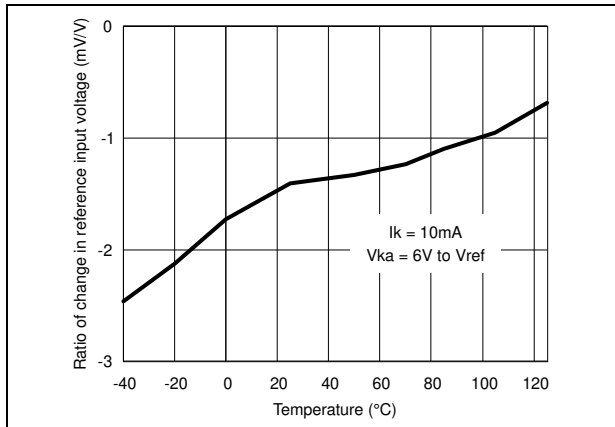

Figure 11. Test circuit for V_{KA} > V_{ref}

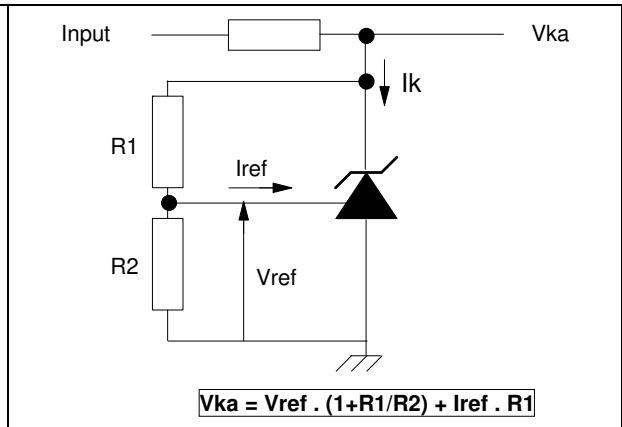

Figure 12. Phase and gain vs. frequency

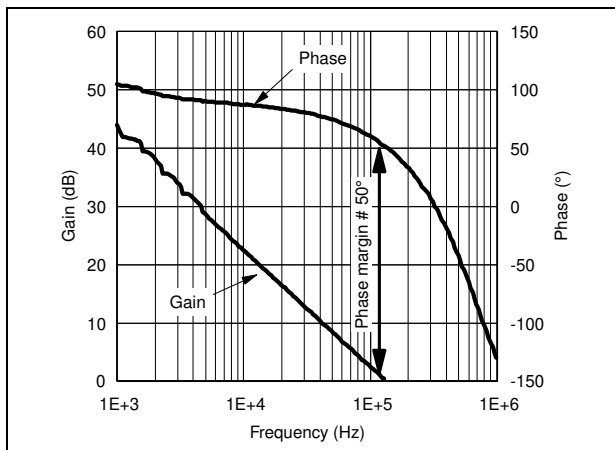

Figure 13. Test circuit for phase and gain measurement

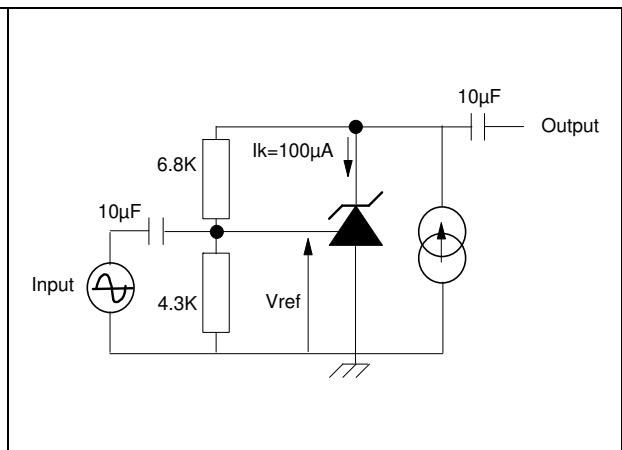

Figure 14. Pulse response at $I_k = 100 \mu A$

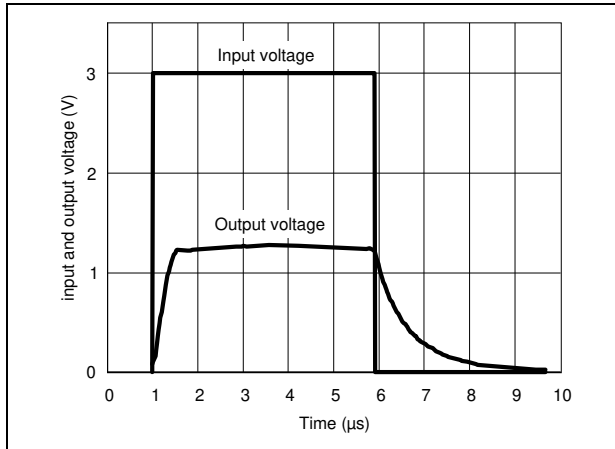

Figure 15. Test circuit for pulse response at $I_k = 100 \mu A$

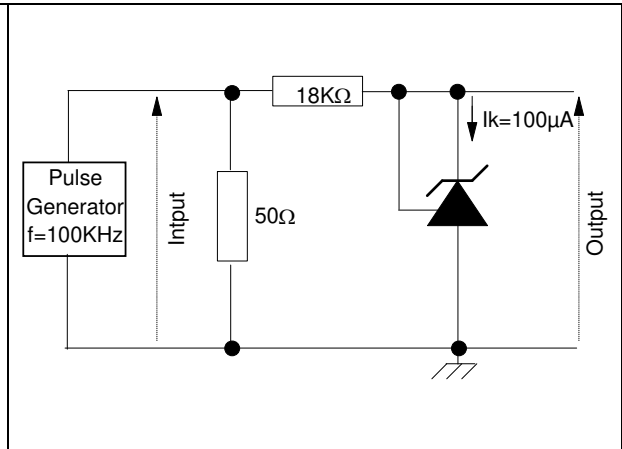

Figure 16. Pulse response at $I_k = 1mA$

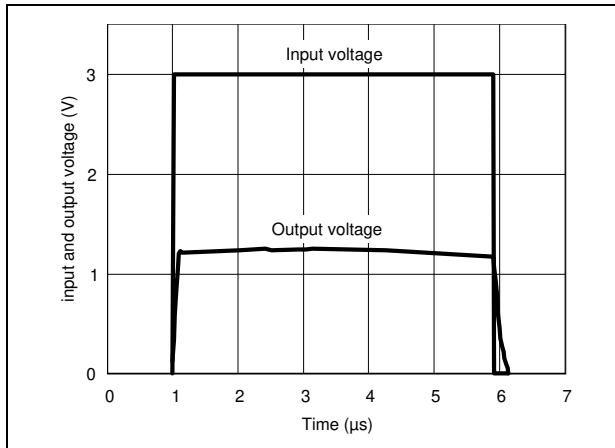

Figure 17. Test circuit for pulse response at $I_k = 1mA$

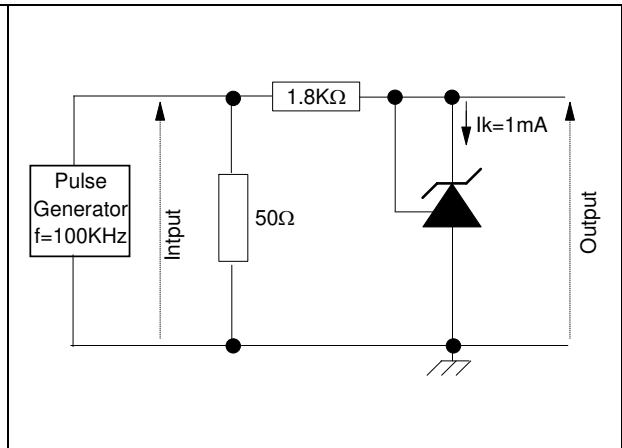
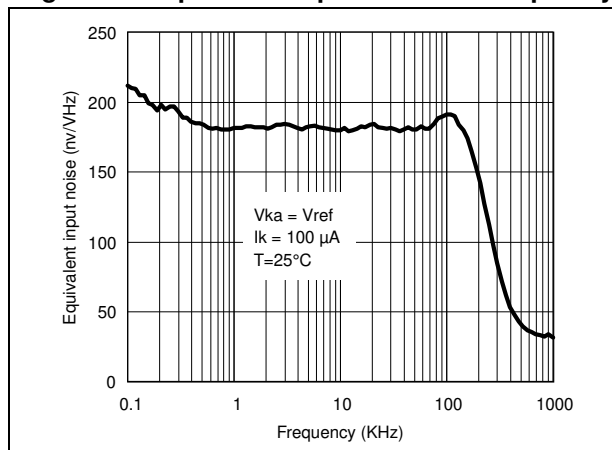

Figure 18. Equivalent input noise vs. frequency



3 Application information

The TS431 is a general-purpose low-power programmable shunt voltage reference, capable of operating with a cathode current as low as 60 μA and up to 30 mA.

The main static parameters of the TS431 voltage reference are specified in [Table 3](#).

Since the TS431 is designed for general-purpose applications with a broad range of cathode currents, voltages and loads, when designing with the device in applications requiring fast dynamic response (turn-on/off and/or pulsed load conditions) it should be considered that upon application of power, the time required for the V_{KA} voltage to reach its final value within a specified error range depends on several factors, among which the temperature, cathode current and capacitive load inrush current are the most influential. The dynamic response of the device to fast turn-on/off, load and temperature changes is optimized when the cathode current is not in the lower end of the operating range ($I_K > 500 \mu\text{A}$).

4 Package information

In order to meet environmental requirements, ST offers these devices in different grades of ECOPACK[®] packages, depending on their level of environmental compliance. ECOPACK[®] specifications, grade definitions and product status are available at: www.st.com. ECOPACK[®] is an ST trademark.

Table 4. SOT23-5 package mechanical data

Ref.	Dimensions					
	Millimeters			Inches		
	Min.	Typ.	Max.	Min.	Typ.	Max.
A	0.90		1.45	0.035		0.057
A1	0.00		0.15	0.00		0.006
A2	0.90		1.30	0.035		0.051
b	0.35		0.50	0.014		0.02
C	0.09		0.20	0.003		0.008
D	2.80		3.00	0.110		0.118
H	2.60		3.00	0.102		0.118
E	1.50		1.75	0.059		0.069
e		0.95			0.037	
e1		1.9			0.075	
L	0.35		0.55	0.014		0.022

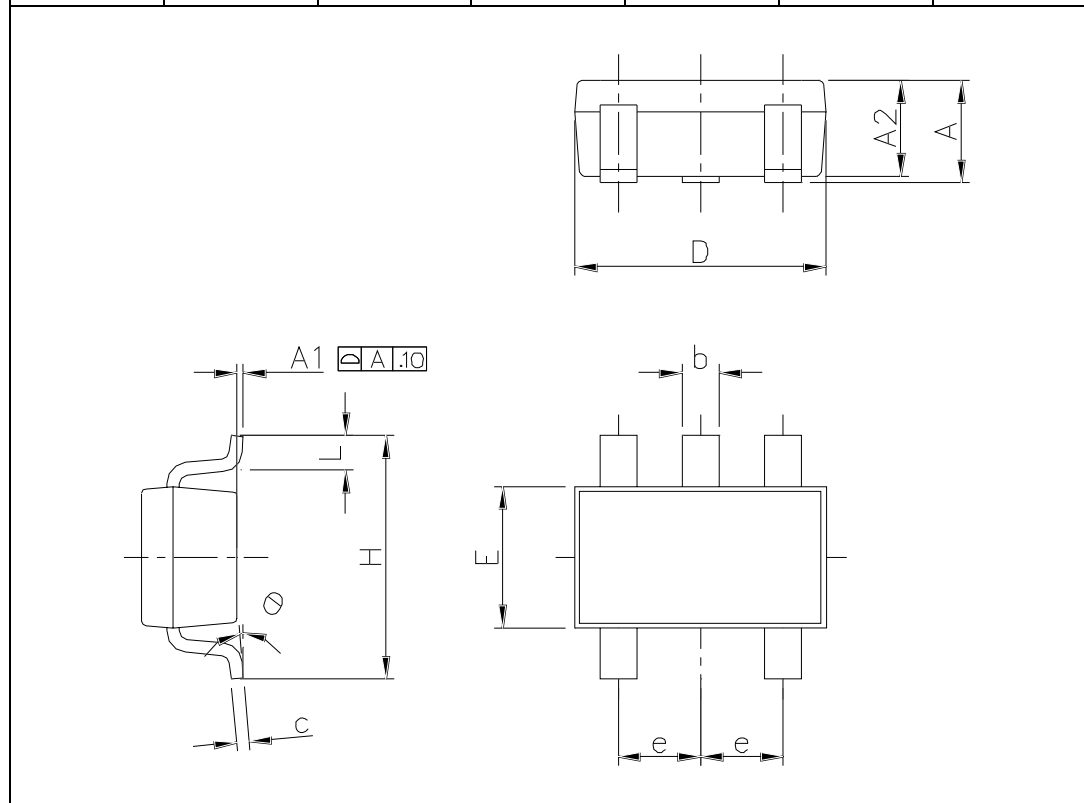
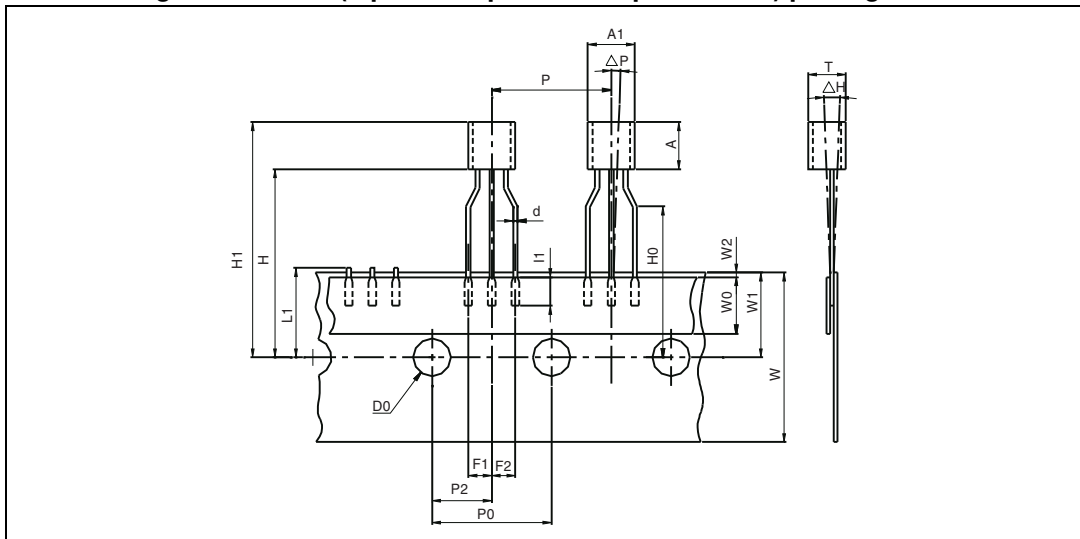
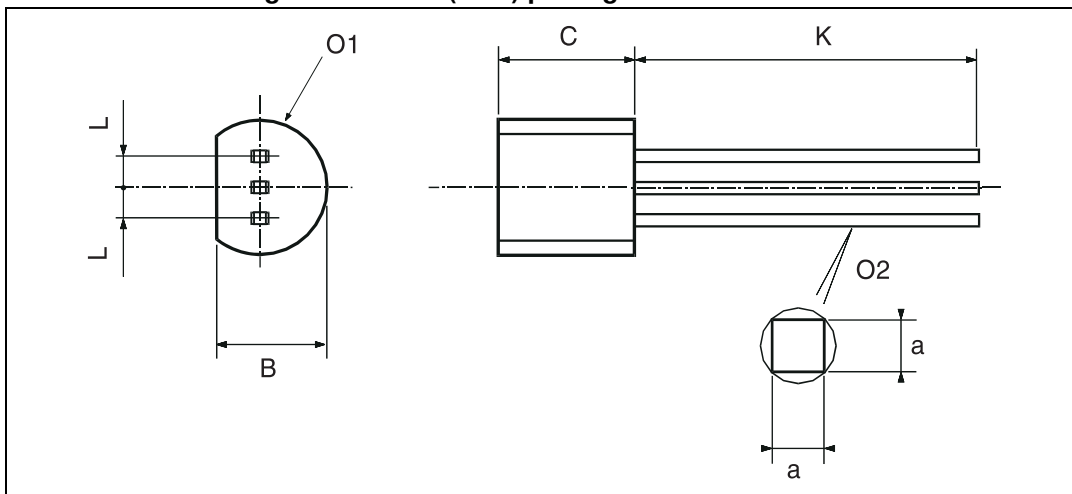

Figure 19. TO92 (tape ammpack and tape and reel) package data



Dim.	Millimeters			Inches		
	Min.	Typ.	Max.	Min.	Typ.	Max.
AL			5.0			0.197
A			5.0			0.197
T			4.0			0.157
d		0.45			0.018	
l1	2.5			0.098		
P	11.7	12.7	13.7	0.461	0.500	0.539
P0	12.4	12.7	13	0.488	0.500	0.512
P2	5.95	6.35	6.75	0.234	0.250	0.266
F1/F2	2.4	2.5	2.8	0.094	0.098	0.110
Δh	-1	0	1	-0.039	0	0.039
ΔP	-1	0	1	-0.039	0	0.039
W	17.5	18.0	19.0	0.689	0.709	0.748
W0	5.7	6	6.3	0.224	0.236	0.248
W1	8.5	9	9.75	0.335	0.354	0.384
W2			0.5			0.020
H			20			0.787
H0	15.5	16	16.5	0.610	0.630	0.650
H1			25			0.984
DO	3.8	4.0	4.2	0.150	0.157	0.165
L1			11			0.433

Figure 20. TO92 (bulk) package mechanical data



Dim.	Millimeters			Inches		
	Min.	Typ.	Max.	Min.	Typ.	Max.
L		1.27			0.05	
B	3.2	3.7	4.2	0.126	0.1457	0.1654
O1	4.45	5.00	5.2	0.1752	0.1969	0.2047
C	4.58	5.03	5.33	0.1803	0.198	0.2098
K	12.7			0.5		
O2	0.407	0.5	0.508	0.016	0.0197	0.02
a	0.35			0.0138		

5 Ordering information

Table 5. Order codes

Order codes	Temperature range	Packages	Packing	Marking
TS431ILT	-40°C, + 125°C	ΣOT23-5	Tape and reel	L272
TS431AILT				L271
TS431BILT				L270
TS431IYLT ⁽¹⁾		ΣOT23-5 (automotive grade level)		L274
TS431AIYLT ⁽¹⁾				L276
TS431BIYLT ⁽¹⁾				L273
TS431IZ/IZT/IZ-AP		TO92	Bulk (Z), Tape and reel (ZT) or Ammo pack (AP)	TS431I
TS431AIZ/AIZT/AIZ-AP				TS431AI
TS431BIZ/BIZT/BIZ-AP				TS431BI

1. Qualification and characterization according to AEC Q100 and Q003 or equivalent, advanced screening according to AEC Q001 & Q 002 or equivalent.

6 Revision history

Table 6. Document revision history

Date	Revision	Changes
1-Sep-2003	1	Initial release.
1-Oct-2005	2	PPAP references inserted in the datasheet. See the order codes table. Minor changes to formatting and grammar.
2-Jan-2006	3	TS431AIYLT PPAP reference inserted. See the order codes table.
22-Sep-2006	4	Included footnote on automotive grade qualification to order codes table. Updated package information (changed mils to inches).
25-Apr-2007	5	Resized graphics on cover page. Moved definition of output voltage change from Table 3 footnote to separate section below table. Corrected errors in SOT23-5 package mechanical data. Removed erroneous drawing for TO92 tape & reel package.
30-Aug-2007	6	Updated drawing for TO92 bulk package. Modified footnote related to automotive grade qualification in Table 5: Order codes , and re-ordered order codes.
27-Aug-2010	7	Modified note for package SOT23-5 on page 1.
15-Nov-2012	8	Modified note 1 Table 5 on page 12 .
17-Dec-2012	9	Added note 1 Table 2 on page 2 and Section 3 on page 7 .
12-Mar-2013	10	Added features Automotive grade version available in cover page.

Please Read Carefully:

Information in this document is provided solely in connection with ST products. STMicroelectronics NV and its subsidiaries ("ST") reserve the right to make changes, corrections, modifications or improvements, to this document, and the products and services described herein at any time, without notice.

All ST products are sold pursuant to ST's terms and conditions of sale.

Purchasers are solely responsible for the choice, selection and use of the ST products and services described herein, and ST assumes no liability whatsoever relating to the choice, selection or use of the ST products and services described herein.

No license, express or implied, by estoppel or otherwise, to any intellectual property rights is granted under this document. If any part of this document refers to any third party products or services it shall not be deemed a license grant by ST for the use of such third party products or services, or any intellectual property contained therein or considered as a warranty covering the use in any manner whatsoever of such third party products or services or any intellectual property contained therein.

UNLESS OTHERWISE SET FORTH IN ST'S TERMS AND CONDITIONS OF SALE ST DISCLAIMS ANY EXPRESS OR IMPLIED WARRANTY WITH RESPECT TO THE USE AND/OR SALE OF ST PRODUCTS INCLUDING WITHOUT LIMITATION IMPLIED WARRANTIES OF MERCHANTABILITY, FITNESS FOR A PARTICULAR PURPOSE (AND THEIR EQUIVALENTS UNDER THE LAWS OF ANY JURISDICTION), OR INFRINGEMENT OF ANY PATENT, COPYRIGHT OR OTHER INTELLECTUAL PROPERTY RIGHT.

ST PRODUCTS ARE NOT AUTHORIZED FOR USE IN WEAPONS. NOR ARE ST PRODUCTS DESIGNED OR AUTHORIZED FOR USE IN: (A) SAFETY CRITICAL APPLICATIONS SUCH AS LIFE SUPPORTING, ACTIVE IMPLANTED DEVICES OR SYSTEMS WITH PRODUCT FUNCTIONAL SAFETY REQUIREMENTS; (B) AERONAUTIC APPLICATIONS; (C) AUTOMOTIVE APPLICATIONS OR ENVIRONMENTS, AND/OR (D) AEROSPACE APPLICATIONS OR ENVIRONMENTS. WHERE ST PRODUCTS ARE NOT DESIGNED FOR SUCH USE, THE PURCHASER SHALL USE PRODUCTS AT PURCHASER'S SOLE RISK, EVEN IF ST HAS BEEN INFORMED IN WRITING OF SUCH USAGE, UNLESS A PRODUCT IS EXPRESSLY DESIGNATED BY ST AS BEING INTENDED FOR "AUTOMOTIVE, AUTOMOTIVE SAFETY OR MEDICAL" INDUSTRY DOMAINS ACCORDING TO ST PRODUCT DESIGN SPECIFICATIONS. PRODUCTS FORMALLY ESCC, QML OR JAN QUALIFIED ARE DEEMED SUITABLE FOR USE IN AEROSPACE BY THE CORRESPONDING GOVERNMENTAL AGENCY.

Resale of ST products with provisions different from the statements and/or technical features set forth in this document shall immediately void any warranty granted by ST for the ST product or service described herein and shall not create or extend in any manner whatsoever, any liability of ST.

ST and the ST logo are trademarks or registered trademarks of ST in various countries.

Information in this document supersedes and replaces all information previously supplied.

The ST logo is a registered trademark of STMicroelectronics. All other names are the property of their respective owners.

© 2013 STMicroelectronics - All rights reserved

STMicroelectronics group of companies

Australia - Belgium - Brazil - Canada - China - Czech Republic - Finland - France - Germany - Hong Kong - India - Israel - Italy - Japan - Malaysia - Malta - Morocco - Philippines - Singapore - Spain - Sweden - Switzerland - United Kingdom - United States of America

www.st.com