



Chipsmall Limited consists of a professional team with an average of over 10 year of expertise in the distribution of electronic components. Based in Hongkong, we have already established firm and mutual-benefit business relationships with customers from,Europe,America and south Asia,supplying obsolete and hard-to-find components to meet their specific needs.

With the principle of “Quality Parts,Customers Priority,Honest Operation,and Considerate Service”,our business mainly focus on the distribution of electronic components. Line cards we deal with include Microchip,ALPS,ROHM,Xilinx,Pulse,ON,Everlight and Freescale. Main products comprise IC,Modules,Potentiometer,IC Socket,Relay,Connector.Our parts cover such applications as commercial,industrial, and automotives areas.

We are looking forward to setting up business relationship with you and hope to provide you with the best service and solution. Let us make a better world for our industry!



Contact us

Tel: +86-755-8981 8866 Fax: +86-755-8427 6832

Email & Skype: info@chipsmall.com Web: www.chipsmall.com

Address: A1208, Overseas Decoration Building, #122 Zhenhua RD., Futian, Shenzhen, China



Output rail-to-rail operational amplifiers

Features

- High dynamic features
- Large output swing ($\pm 2.4\text{ V}$ at $V_{CC} = \pm 2.5\text{ V}$)
- Low noise level: $4\text{ nV}/\sqrt{\text{Hz}}$
- Low distortion: 0.003%
- Operating range: 2.7 V to 10 V
- Available in SOT23-5 micropackage

Applications

- Sound cards
- PDAs
- CD players
- Recording equipment
- Multimedia
- Microphone pre-amplifiers

Description

The TS461, TS462 and TS464 family of operational amplifiers can operate with voltages as low as $\pm 1.35\text{ V}$ and reach a minimum of $\pm 2\text{ V}_{pp}$ of output swing when supplied with $\pm 2.5\text{ V}$.

The devices are well-suited to all kinds of portable and battery-supplied equipment, where low noise and low distortion are key requirements.

The TS461, TS462 and TS464 offer excellent output rail-to-rail performances at an attractive cost.

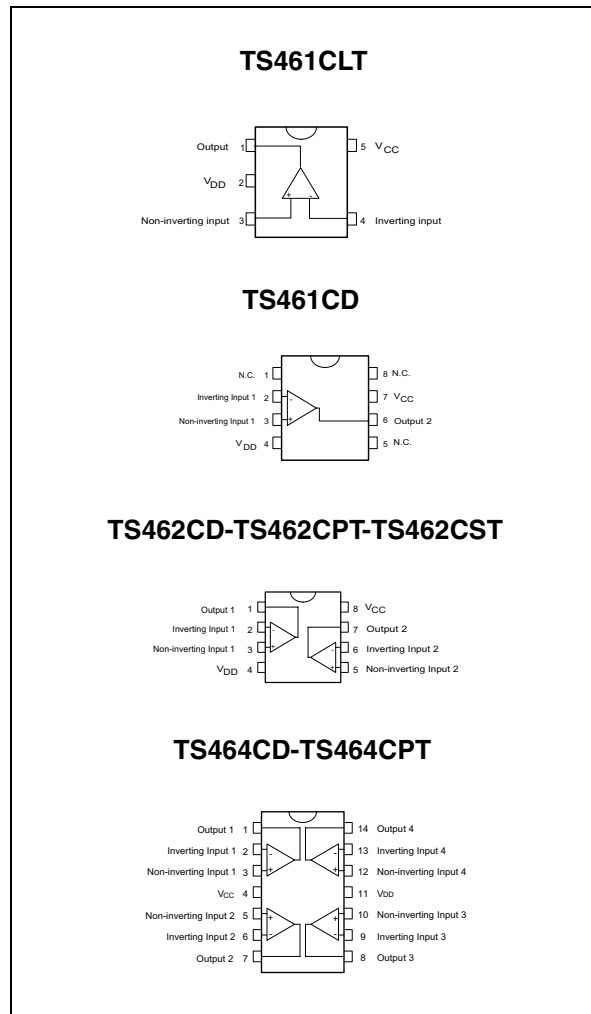

1 Absolute maximum ratings and operating conditions

Table 1. Key parameters and their absolute maximum ratings

Symbol	Parameter	Value	Unit
V_{CC}	Supply voltage ⁽¹⁾	12	V
V_{id}	Differential Input Voltage ⁽²⁾	$\pm V_{CC}$	V
V_{in}	Input voltage range	$V_{DD} - 0.3$ to $V_{CC} + 0.3$	V
T_{oper}	Operating free air temperature range	-20 to +70	°C
T_{std}	Storage temperature range	-65 to +150	°C
T_j	Maximum junction temperature	150	°C
R_{thja}	Thermal resistance junction to case ⁽³⁾		
	SOT23-5	250	°C/W
	SO8	125	
	SO14	103	
	TSSOP8	120	
TSSOP14	100		
ESD	HBM: human body model ⁽⁴⁾	2	kV
	MM: machine model ⁽⁵⁾	200	V
	CDM: charged device model	1.5	kV
	Lead temperature (soldering, 10 sec)	250	°C

1. All voltages values, except differential voltage are with respect to network group terminal.
2. Differential voltages are non-inverting input terminal with respect to the inverting input terminal.
3. Short-circuits can cause excessive heating and destructive dissipation.
4. Human body model: 100 pF discharged through a 1.5 k Ω resistor into pin of device.
5. Machine model ESD: a 200 pF capacitor is charged to the specified voltage, then discharged directly into the IC with no external series resistor (internal resistor < 5 Ω), into pin-to-pin of device.

Table 2. Operating conditions

Symbol	Parameter	Value	Unit
V_{CC}	Supply voltage	2.7 to 10	V
V_{icm}	Common mode input voltage range	$V_{DD} + 1.15$ to $V_{CC} - 1.15$	V
T_{oper}	Operating free air temperature range	-20 to +70	°C

2 Electrical characteristics

Table 3. $V_{CC} = 2.5\text{ V}$, $V_{DD} = -2.5\text{ V}$, $V_{icm} = V_{CC} / 2$, R_L connected to $V_{CC} / 2$,
 $T_{amb} = 25^\circ\text{ C}$ (unless otherwise specified)

Symbol	Parameter	Min.	Typ.	Max.	Unit
V_{io}	Input offset voltage $T_{min.} \leq T_{amb} \leq T_{max.}$		1	5 7	mV
ΔV_{io}	Input offset voltage drift		5		$\mu\text{V}/^\circ\text{C}$
I_{io}	Input offset current $T_{min.} \leq T_{amb} \leq T_{max.}$		10	150 200	nA
I_{ib}	Input bias current $T_{min.} \leq T_{amb} \leq T_{max.}$		200 200	750 1000	nA
CMR	Common mode rejection ratio $V_{icm} = \pm 1.35\text{ V}$	60	85		dB
SVR	Supply voltage rejection ratio $V_{CC} = \pm 2\text{ V to } \pm 3\text{ V}$	60	70		dB
A_{vd}	Large signal voltage gain $R_L = 2\text{ k}\Omega$	70	80		dB
V_{OH}	High level output voltage $R_L = 2\text{ k}\Omega$	2	2.4		V
V_{OL}	Low level output voltage $R_L = 2\text{ k}\Omega$		-2.4	-2	V
I_{CC}	Supply current, per amplifier Unity gain - no load		2	2.8	mA
GBP	Gain bandwidth product $f = 100\text{ kHz}$, $R_L = 2\text{ k}\Omega$, $C_L = 100\text{ pF}$	8.5	12		MHz
SR	Slew rate $A_V = 1$, $V_{in} = \pm 1\text{ V}$	2.8	4		$\text{V}/\mu\text{s}$
e_n	Equivalent input noise voltage $f = 100\text{ kHz}$		4		$\frac{\text{nV}}{\sqrt{\text{Hz}}}$
THD	Total harmonic distortion $f = 1\text{ kHz}$, $A_V = -1$, $R_L = 10\text{ k}\Omega$		0.003		%

3 Package information

In order to meet environmental requirements, ST offers these devices in different grades of ECOPACK[®] packages, depending on their level of environmental compliance. ECOPACK[®] specifications, grade definitions and product status are available at: www.st.com. ECOPACK[®] is an ST trademark.

3.1 SOT23-5 package information

Figure 1. SOT23-5 package mechanical drawing

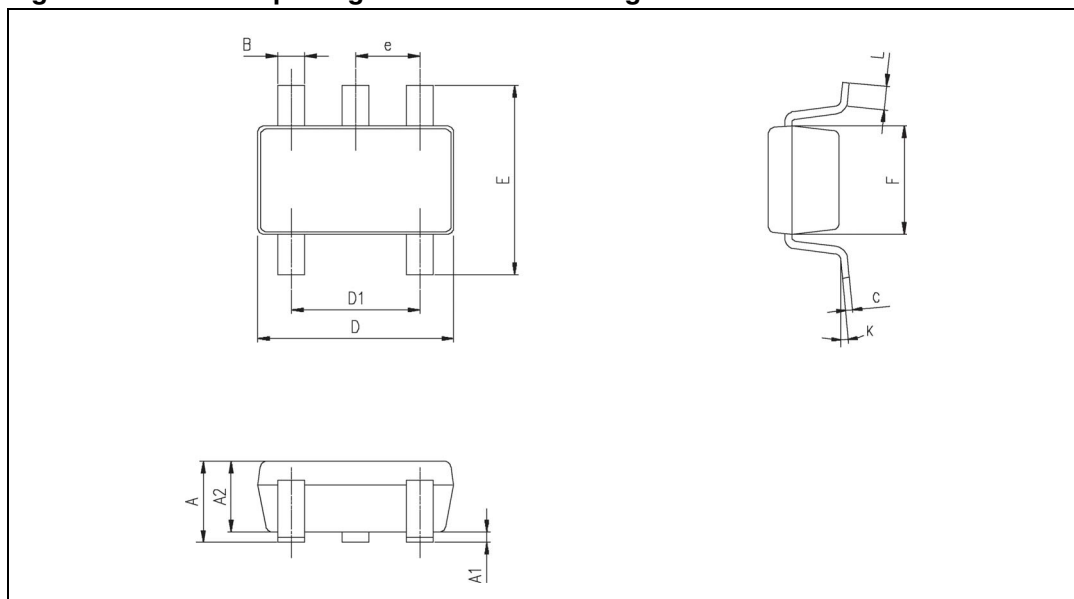

Table 4. SOT23-5 package mechanical data

Ref.	Dimensions					
	Millimeters			Inches		
	Min.	Typ.	Max.	Min.	Typ.	Max.
A	0.90	1.20	1.45	0.035	0.047	0.057
A1			0.15			0.006
A2	0.90	1.05	1.30	0.035	0.041	0.051
B	0.35	0.40	0.50	0.013	0.015	0.019
C	0.09	0.15	0.20	0.003	0.006	0.008
D	2.80	2.90	3.00	0.110	0.114	0.118
D1		1.90			0.075	
e		0.95			0.037	
E	2.60	2.80	3.00	0.102	0.110	0.118
F	1.50	1.60	1.75	0.059	0.063	0.069
L	0.10	0.35	0.60	0.004	0.013	0.023
K	0 degrees		10 degrees			

3.2 SO-8 package information

Figure 2. SO-8 package mechanical drawing

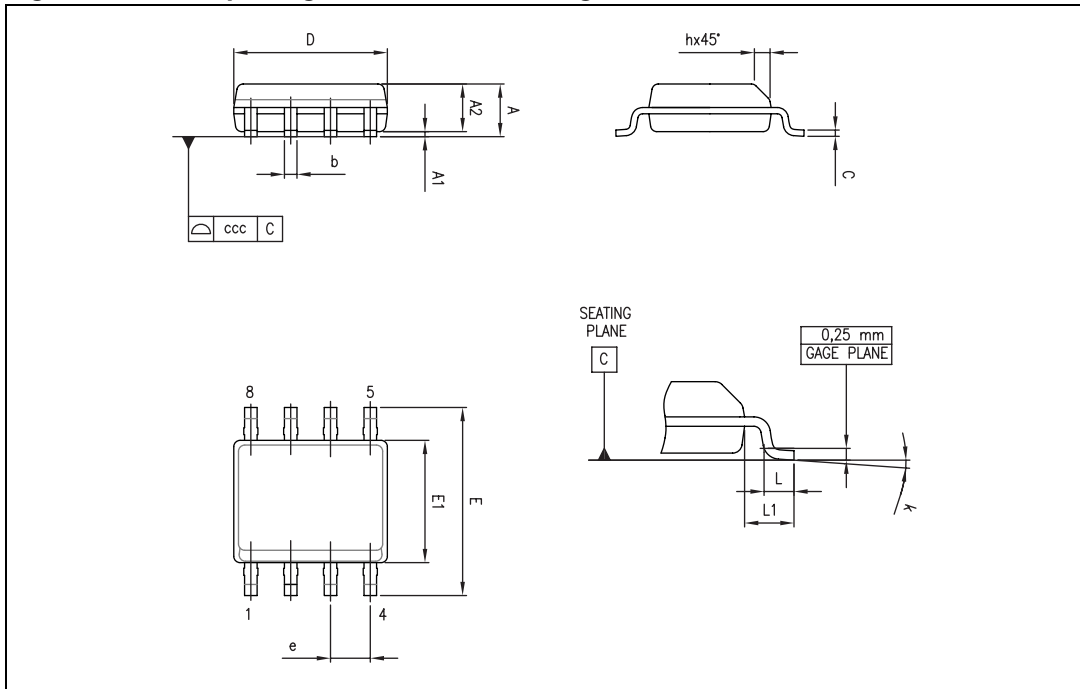

Table 5. SO-8 package mechanical data

Ref.	Dimensions					
	Millimeters			Inches		
	Min.	Typ.	Max.	Min.	Typ.	Max.
A			1.75			0.069
A1	0.10		0.25	0.004		0.010
A2	1.25			0.049		
b	0.28		0.48	0.011		0.019
c	0.17		0.23	0.007		0.010
D	4.80	4.90	5.00	0.189	0.193	0.197
E	5.80	6.00	6.20	0.228	0.236	0.244
E1	3.80	3.90	4.00	0.150	0.154	0.157
e		1.27			0.050	
h	0.25		0.50	0.010		0.020
L	0.40		1.27	0.016		0.050
L1		1.04			0.040	
k	1°		8°	1°		8°
ccc			0.10			0.004

3.3 MiniSO-8 package information

Figure 3. MiniSO-8 package mechanical drawing

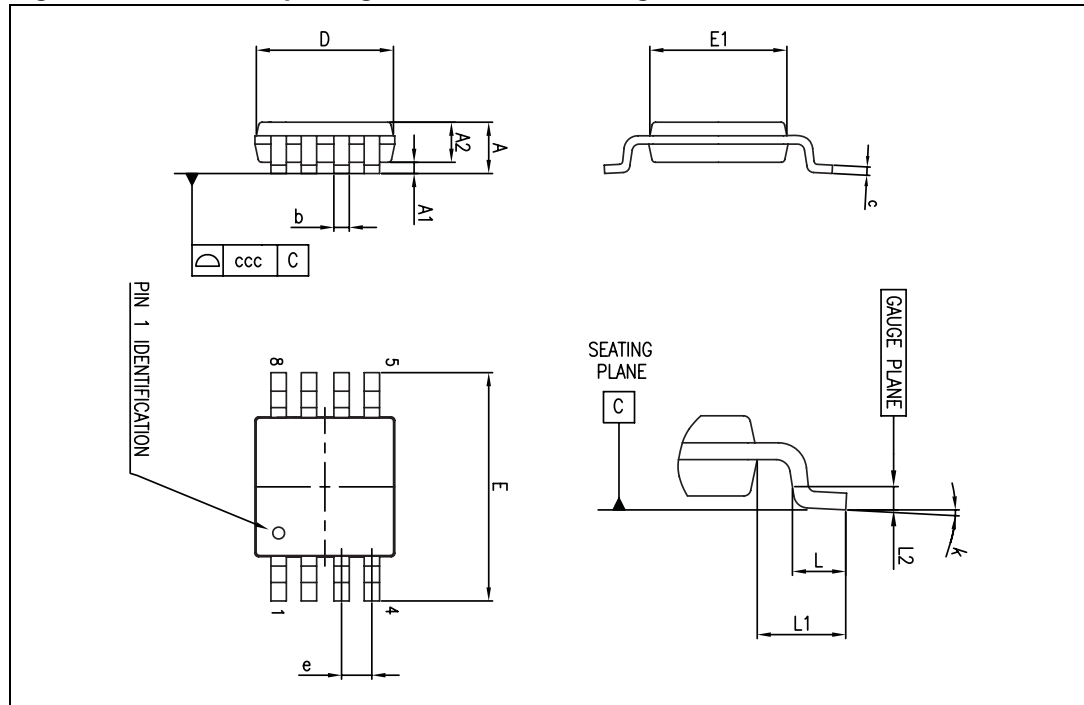

Table 6. MiniSO-8 package mechanical data

Ref.	Dimensions					
	Millimeters			Inches		
	Min.	Typ.	Max.	Min.	Typ.	Max.
A			1.1			0.043
A1	0		0.15	0		0.006
A2	0.75	0.85	0.95	0.030	0.033	0.037
b	0.22		0.40	0.009		0.016
c	0.08		0.23	0.003		0.009
D	2.80	3.00	3.20	0.11	0.118	0.126
E	4.65	4.90	5.15	0.183	0.193	0.203
E1	2.80	3.00	3.10	0.11	0.118	0.122
e		0.65			0.026	
L	0.40	0.60	0.80	0.016	0.024	0.031
L1		0.95			0.037	
L2		0.25			0.010	
k	0°		8°	0°		8°
ccc			0.10			0.004

3.4 TSSOP8 package information

Figure 4. TSSOP8 package mechanical drawing

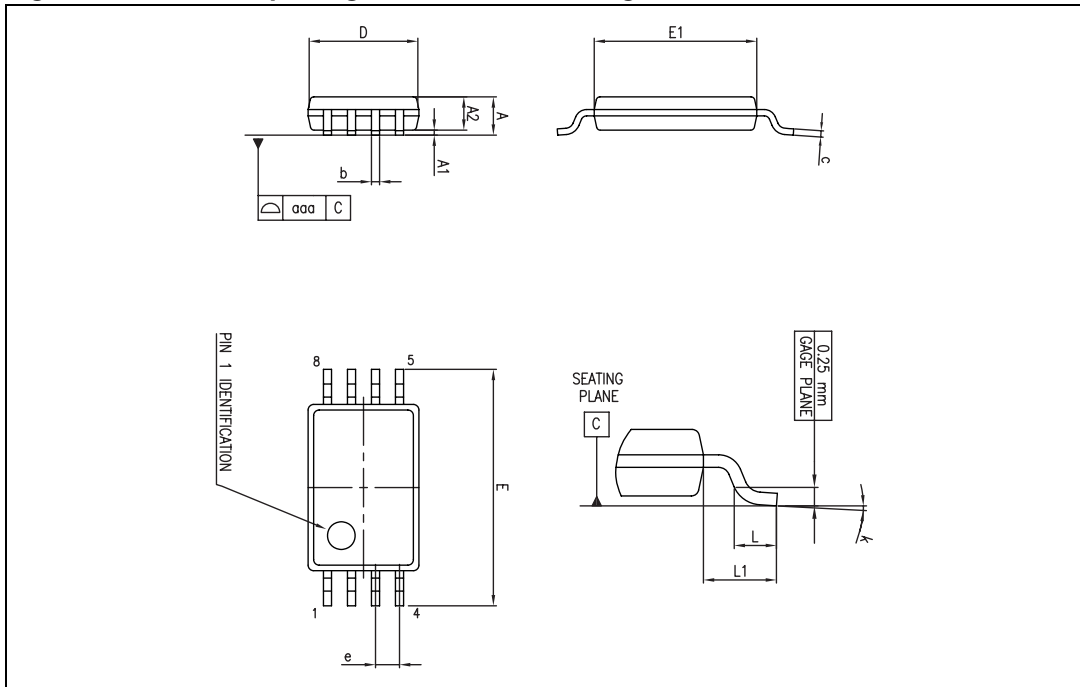

Table 7. TSSOP8 package mechanical data

Ref.	Dimensions					
	Millimeters			Inches		
	Min.	Typ.	Max.	Min.	Typ.	Max.
A			1.20			0.047
A1	0.05		0.15	0.002		0.006
A2	0.80	1.00	1.05	0.031	0.039	0.041
b	0.19		0.30	0.007		0.012
c	0.09		0.20	0.004		0.008
D	2.90	3.00	3.10	0.114	0.118	0.122
E	6.20	6.40	6.60	0.244	0.252	0.260
E1	4.30	4.40	4.50	0.169	0.173	0.177
e		0.65			0.0256	
k	0°		8°	0°		8°
L	0.45	0.60	0.75	0.018	0.024	0.030
L1		1			0.039	
aaa			0.10			0.004

3.5 TSSOP14 package information

Figure 5. TSSOP14 package mechanical drawing

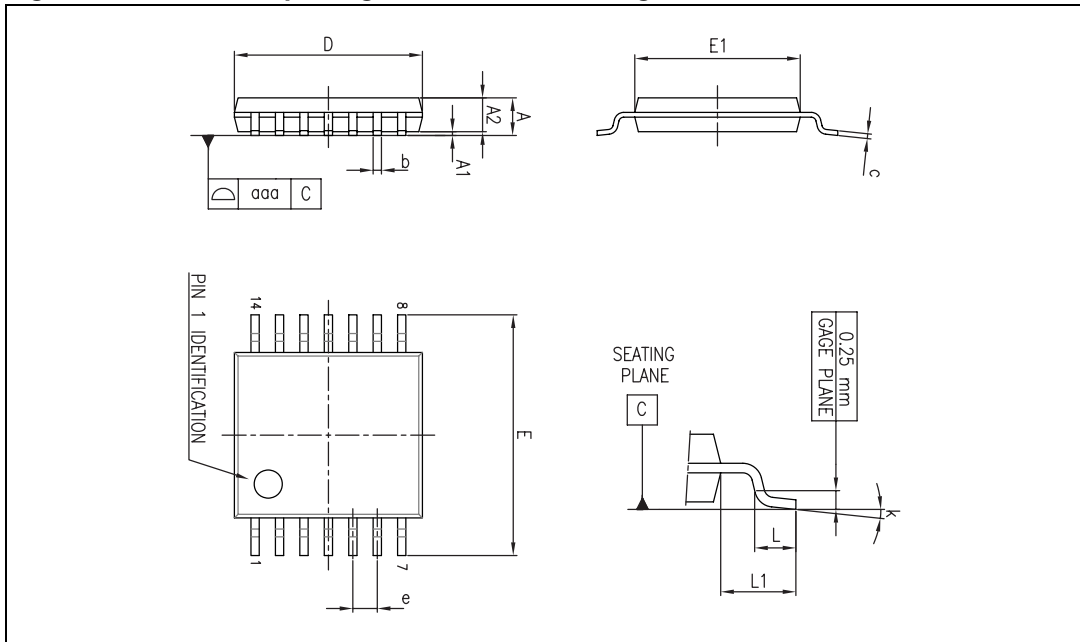

Table 8. TSSOP14 package mechanical data

Ref.	Dimensions					
	Millimeters			Inches		
	Min.	Typ.	Max.	Min.	Typ.	Max.
A			1.20			0.047
A1	0.05		0.15	0.002	0.004	0.006
A2	0.80	1.00	1.05	0.031	0.039	0.041
b	0.19		0.30	0.007		0.012
c	0.09		0.20	0.004		0.0089
D	4.90	5.00	5.10	0.193	0.197	0.201
E	6.20	6.40	6.60	0.244	0.252	0.260
E1	4.30	4.40	4.50	0.169	0.173	0.176
e		0.65			0.0256	
L	0.45	0.60	0.75	0.018	0.024	0.030
L1		1.00			0.039	
k	0°		8°	0°		8°
aaa			0.10			0.004

3.6 SO-14 package information

Figure 6. SO-14 package mechanical drawing

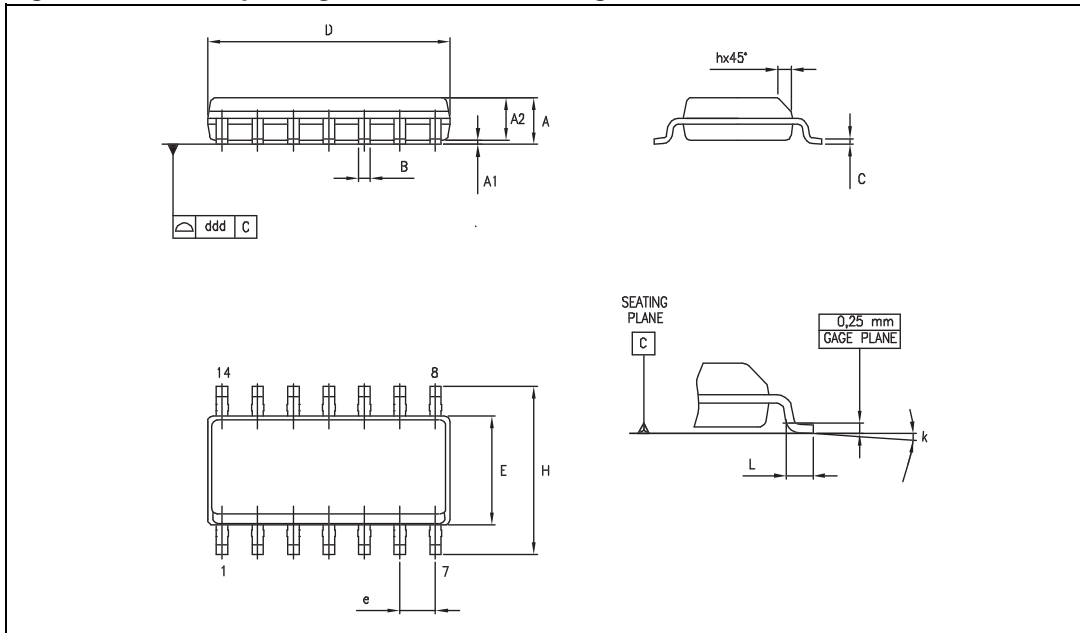

Table 9. SO-14 package mechanical data

Dimensions						
Ref.	Millimeters			Inches		
	Min.	Typ.	Max.	Min.	Typ.	Max.
A	1.35		1.75	0.05		0.068
A1	0.10		0.25	0.004		0.009
A2	1.10		1.65	0.04		0.06
B	0.33		0.51	0.01		0.02
C	0.19		0.25	0.007		0.009
D	8.55		8.75	0.33		0.34
E	3.80		4.0	0.15		0.15
e		1.27			0.05	
H	5.80		6.20	0.22		0.24
h	0.25		0.50	0.009		0.02
L	0.40		1.27	0.015		0.05
k	8° (max.)					
ddd			0.10			0.004

4 Ordering information

Table 10. Order codes

Order code	Temperature range	Package	Packing	Marking
TS461CLT	-20° C, +70° C	SOT23-5L	Tape & reel	K105
TS461CD TS461CDT		SO-8	Tube Tape & reel	461C
TS462CST		Mini SO-8	Tape & reel	K105
TS462CPT		TSSOP-8 (Thin shrink small outline package)	Tape & reel	462C
TS462CD TS462CDT		SO-8	Tube Tape & reel	462C
TS464CPT		TSSOP-14 (Thin shrink small outline package)	Tape & reel	464C
TS464CD TS464CDT		SO-14	Tube Tape & reel	464C

5 Revision history

Table 11. Document revision history

Date	Revision	Changes
01-Jan-2002	1	Initial release.
01-Mar-2005	2	Modified <i>Table 1: Key parameters and their absolute maximum ratings on page 2</i> (explanation of Vid and Vi limits).
02-Apr-2009	3	Document reformatted. Removed order codes in DIP package.

Please Read Carefully:

Information in this document is provided solely in connection with ST products. STMicroelectronics NV and its subsidiaries ("ST") reserve the right to make changes, corrections, modifications or improvements, to this document, and the products and services described herein at any time, without notice.

All ST products are sold pursuant to ST's terms and conditions of sale.

Purchasers are solely responsible for the choice, selection and use of the ST products and services described herein, and ST assumes no liability whatsoever relating to the choice, selection or use of the ST products and services described herein.

No license, express or implied, by estoppel or otherwise, to any intellectual property rights is granted under this document. If any part of this document refers to any third party products or services it shall not be deemed a license grant by ST for the use of such third party products or services, or any intellectual property contained therein or considered as a warranty covering the use in any manner whatsoever of such third party products or services or any intellectual property contained therein.

UNLESS OTHERWISE SET FORTH IN ST'S TERMS AND CONDITIONS OF SALE ST DISCLAIMS ANY EXPRESS OR IMPLIED WARRANTY WITH RESPECT TO THE USE AND/OR SALE OF ST PRODUCTS INCLUDING WITHOUT LIMITATION IMPLIED WARRANTIES OF MERCHANTABILITY, FITNESS FOR A PARTICULAR PURPOSE (AND THEIR EQUIVALENTS UNDER THE LAWS OF ANY JURISDICTION), OR INFRINGEMENT OF ANY PATENT, COPYRIGHT OR OTHER INTELLECTUAL PROPERTY RIGHT.

UNLESS EXPRESSLY APPROVED IN WRITING BY AN AUTHORIZED ST REPRESENTATIVE, ST PRODUCTS ARE NOT RECOMMENDED, AUTHORIZED OR WARRANTED FOR USE IN MILITARY, AIR CRAFT, SPACE, LIFE SAVING, OR LIFE SUSTAINING APPLICATIONS, NOR IN PRODUCTS OR SYSTEMS WHERE FAILURE OR MALFUNCTION MAY RESULT IN PERSONAL INJURY, DEATH, OR SEVERE PROPERTY OR ENVIRONMENTAL DAMAGE. ST PRODUCTS WHICH ARE NOT SPECIFIED AS "AUTOMOTIVE GRADE" MAY ONLY BE USED IN AUTOMOTIVE APPLICATIONS AT USER'S OWN RISK.

Resale of ST products with provisions different from the statements and/or technical features set forth in this document shall immediately void any warranty granted by ST for the ST product or service described herein and shall not create or extend in any manner whatsoever, any liability of ST.

ST and the ST logo are trademarks or registered trademarks of ST in various countries.

Information in this document supersedes and replaces all information previously supplied.

The ST logo is a registered trademark of STMicroelectronics. All other names are the property of their respective owners.

© 2009 STMicroelectronics - All rights reserved

STMicroelectronics group of companies

Australia - Belgium - Brazil - Canada - China - Czech Republic - Finland - France - Germany - Hong Kong - India - Israel - Italy - Japan - Malaysia - Malta - Morocco - Singapore - Spain - Sweden - Switzerland - United Kingdom - United States of America

www.st.com

