



Chipsmall Limited consists of a professional team with an average of over 10 year of expertise in the distribution of electronic components. Based in Hongkong, we have already established firm and mutual-benefit business relationships with customers from,Europe,America and south Asia,supplying obsolete and hard-to-find components to meet their specific needs.

With the principle of “Quality Parts,Customers Priority,Honest Operation,and Considerate Service”,our business mainly focus on the distribution of electronic components. Line cards we deal with include Microchip,ALPS,ROHM,Xilinx,Pulse,ON,Everlight and Freescale. Main products comprise IC,Modules,Potentiometer,IC Socket,Relay,Connector.Our parts cover such applications as commercial,industrial, and automotives areas.

We are looking forward to setting up business relationship with you and hope to provide you with the best service and solution. Let us make a better world for our industry!



Contact us

Tel: +86-755-8981 8866 Fax: +86-755-8427 6832

Email & Skype: info@chipsmall.com Web: www.chipsmall.com

Address: A1208, Overseas Decoration Building, #122 Zhenhua RD., Futian, Shenzhen, China



LOW POWER SINGLE CMOS TIMER

- VERY LOW POWER CONSUMPTION :
110 μ A typ at $V_{CC} = 5V$
90 μ A typ at $V_{CC} = 3V$
- HIGH MAXIMUM ASTABLE FREQUENCY
2.7MHz
- PIN-TO-PIN AND FUNCTIONALLY
COMPATIBLE WITH BIPOLAR NE555
- WIDE VOLTAGE RANGE : +2V to +16V
- HIGH OUTPUT CURRENT CAPABILITY
- SUPPLY CURRENT SPIKES REDUCED
DURING OUTPUT TRANSITIONS
- HIGH INPUT IMPEDANCE : $10^{12}\Omega$
- OUTPUT COMPATIBLE WITH TTL,CMOS
AND LOGIC MOS

DESCRIPTION

The TS555 is a single CMOS timer which offers very low consumption ($I_{cc(TYP)}$ TS555 = 110 μ A at $V_{CC}=+5V$ versus $I_{cc(TYP)}$ NE555 = 3mA) and high frequency ($f_{(max.)}$ TS555 = 2.7MHz versus $f_{(max.)}$ NE555 = 0.1 MHz)

Thus, either in Monostable or Astable mode, timing remains very accurate.

The TS555 provides reduced supply current spikes during output transitions, which enables the use of lower decoupling capacitors compared to those required by bipolar NE555.

Timing capacitors can also be minimized due to high input impedance ($10^{12}\Omega$).

ORDER CODES

Part Number	Temperature Range	Package		
		N	D	P
TS555C	0°C, +70°C	•	•	•
TS555I	-40°C, +125°C	•	•	•
TS555M	-55°C, +125°C	•	•	•

N = Dual in Line Package (DIP)
D = Small Outline Package (SO) - also available in Tape & Reel (DT)
P = Thin Shrink Small Outline Package (TSSOP) - only available in Tape & Reel (PT)

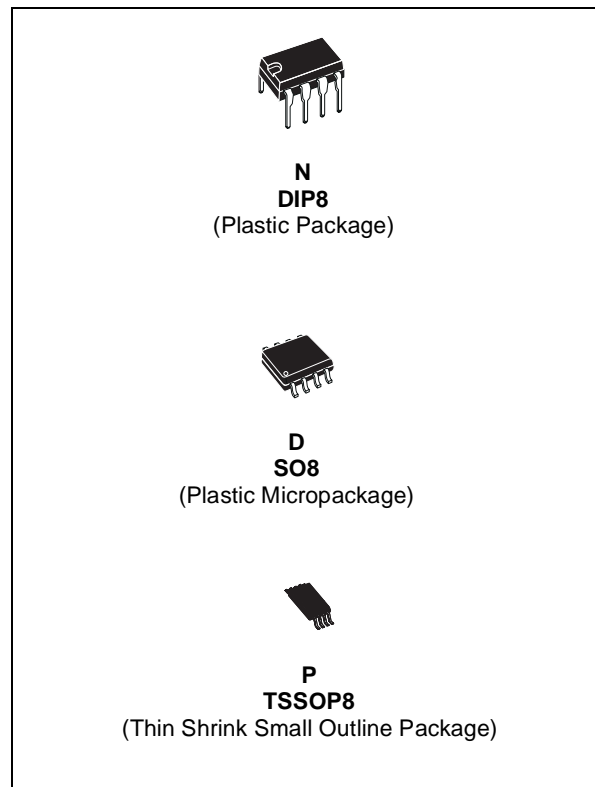

PIN CONNECTIONS (top view)

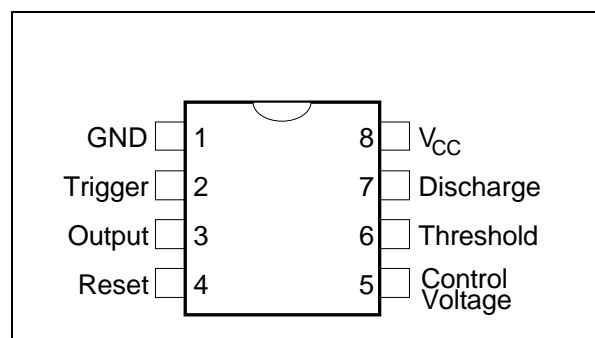

BLOCK DIAGRAM

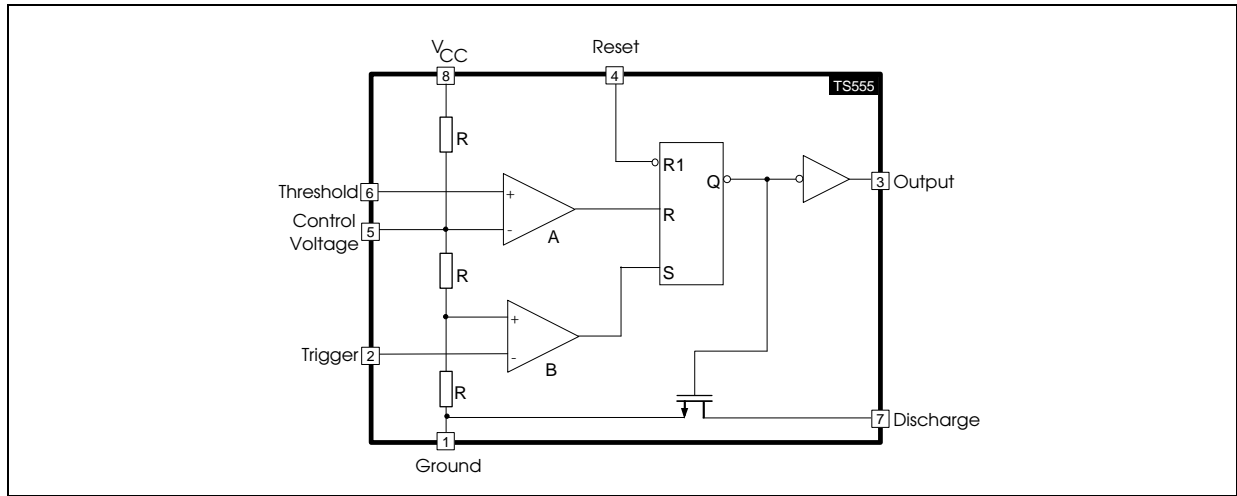

FUNCTION TABLE

RESET	TRIGGER	THRESHOLD	OUTPUT
Low	x	x	Low
High	Low	x	High
High	High	High	Low
High	High	Low	Previous State

LOW <-----> Level Voltage \leq Min voltage specified

HIGH <-----> Level Voltage \geq Max voltage specified

x <-----> Irrelevant

ABSOLUTE MAXIMUM RATINGS

Symbol	Parameter	Value	Unit
V_{CC}	Supply Voltage	+18	V
T_j	Junction Temperature	+150	$^{\circ}C$
T_{stg}	Storage Temperature Range	-65 to +150	$^{\circ}C$
P_D	Power dissipation ¹⁾	DIP8	1250
		SO8	715
		TSSOP8	625

1. $T_j = 150^{\circ}C$, $T_{amb} = 25^{\circ}C$ with $R_{thja} = 100^{\circ}C/W$ for DIP8 package
 $R_{thja} = 175^{\circ}C/W$ for SO8 package
 $R_{thja} = 200^{\circ}C/W$ for TSSOP8 package

OPERATING CONDITIONS

Symbol	Parameter	Value	Unit
V_{CC}	Supply Voltage	+2 to +16	V
T_{oper}	Operating Free Air Temperature Range	TS555C	0 to +70
		TS555I	-40 to +125
		TS555M	-55 to +125

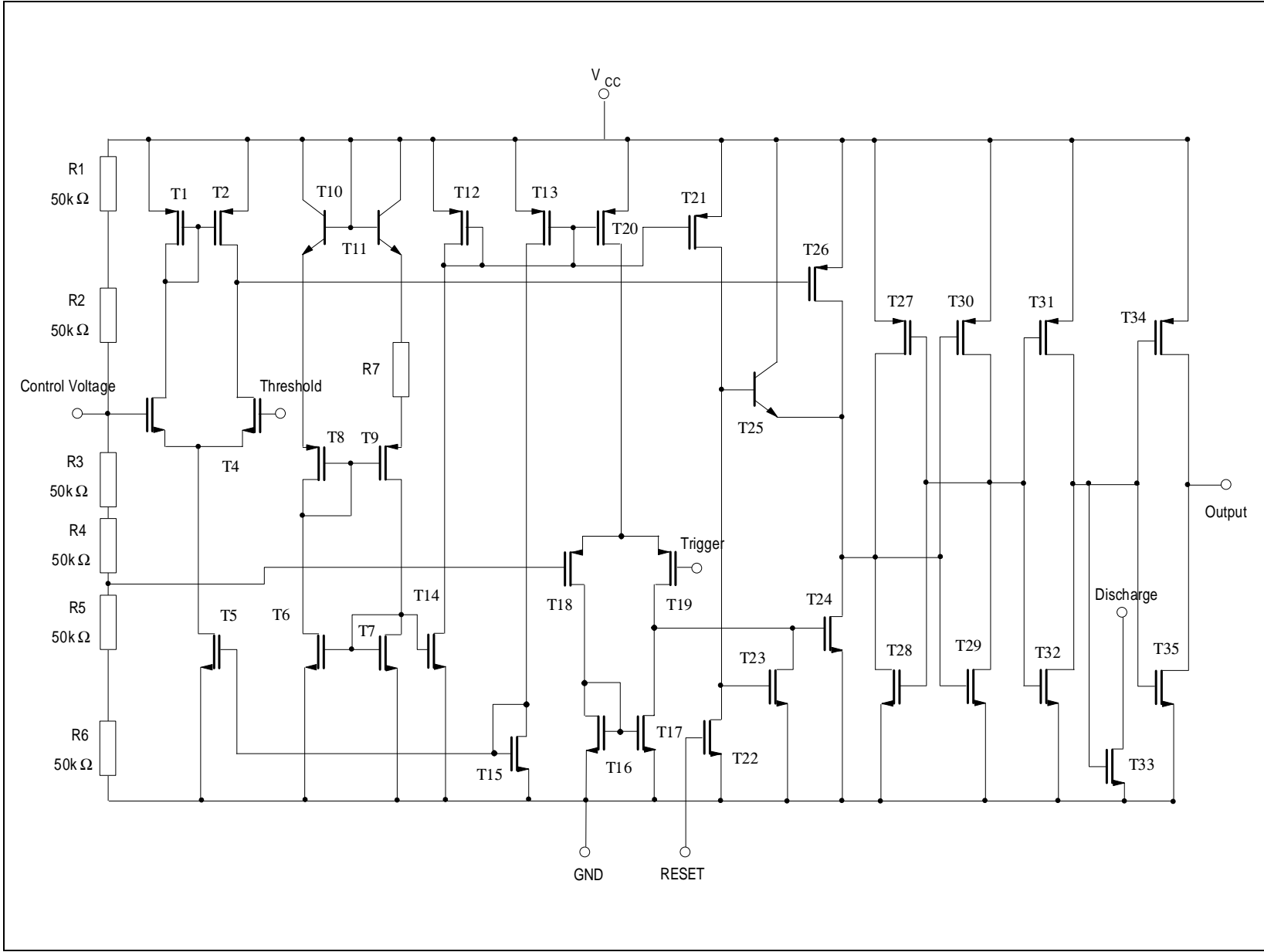

SCHEMATIC DIAGRAM

STATIC ELECTRICAL CHARACTERISTICS

$V_{CC} = +2V$, $T_{amb} = +25^{\circ}C$, Reset to V_{CC} (unless otherwise specified)

Symbol	Parameter	Min.	Typ.	Max.	Unit
I_{CC}	Supply Current (no load, High and Low States) $T_{min.} \leq T_{amb} \leq T_{max.}$		65	200 200	μA
V_{CL}	Control Voltage Level $T_{min.} \leq T_{amb} \leq T_{max.}$	1.2 1.1	1.3	1.4 1.5	V
V_{DIS}	Discharge Saturation Voltage ($I_{dis} = 1mA$) $T_{min.} \leq T_{amb} \leq T_{max.}$		0.05	0.2 0.25	V
I_{DIS}	Discharge Pin Leakage Current		1	100	nA
V_{OL}	Low Level Output Voltage ($I_{sink} = 1mA$) $T_{min.} \leq T_{amb} \leq T_{max.}$		0.1	0.3 0.35	V
V_{OH}	High Level Output Voltage ($I_{source} = -0.3mA$) $T_{min.} \leq T_{amb} \leq T_{max.}$	1.5 1.5	1.9		V
V_{TRIG}	Trigger Voltage $T_{min.} \leq T_{amb} \leq T_{max.}$	0.4 0.3	0.67	0.95 1.05	V
I_{TRIG}	Trigger Current		10		pA
I_{TH}	Threshold Current		10		pA
V_{RESET}	Reset Voltage $T_{min.} \leq T_{amb} \leq T_{max.}$	0.4 0.3	1.1	1.5 2.0	V
I_{RESET}	Reset Current		10		pA

ELECTRICAL CHARACTERISTICS

$V_{CC} = +3V$, $T_{amb} = +25^{\circ}C$, Reset to V_{CC} (unless otherwise specified)

Symbol	Parameter	Min.	Typ.	Max.	Unit
I_{CC}	Supply Current (no load, High and Low States) $T_{min.} \leq T_{amb} \leq T_{max.}$		90	230 230	μA
V_{CL}	Control Voltage Level $T_{min.} \leq T_{amb} \leq T_{max.}$	1.8 1.7	2	2.2 2.3	V
V_{DIS}	Discharge Saturation Voltage ($I_{dis} = 1mA$) $T_{min.} \leq T_{amb} \leq T_{max.}$		0.05	0.2 0.25	V
I_{DIS}	Discharge Pin Leakage Current		1	100	nA
V_{OL}	Low Level Output Voltage ($I_{sink} = 1mA$) $T_{min.} \leq T_{amb} \leq T_{max.}$		0.1	0.3 0.35	V
V_{OH}	High Level Output Voltage ($I_{source} = -0.3mA$) $T_{min.} \leq T_{amb} \leq T_{max.}$	2.5 2.5	2.9		V
V_{TRIG}	Trigger Voltage $T_{min.} \leq T_{amb} \leq T_{max.}$	0.9 0.8	1	1.1 1.2	V
I_{TRIG}	Trigger Current		10		μA
I_{TH}	Threshold Current		10		μA
V_{RESET}	Reset Voltage $T_{min.} \leq T_{amb} \leq T_{max.}$	0.4 0.3	1.1	1.5 2.0	V
I_{RESET}	Reset Current		10		μA

DYNAMIC ELECTRICAL CHARACTERISTICS

$V_{CC} = +3V$, $T_{amb} = +25^{\circ}C$, Reset to V_{CC} (unless otherwise specified)

Symbol	Parameter	Min.	Typ.	Max.	Unit
	Timing Accuracy (Monostable) ¹⁾ $R = 10k\Omega$, $C = 0.1\mu F$ $V_{CC}=+2V$ $V_{CC}=+3V$		1 1		%
	Timing Shift with Supply Voltage Variations (Monostable) $R = 10k\Omega$, $C = 0.1\mu F$, $V_{CC} = +3V \pm 0.3V$ ¹⁾		0.5		%/V
	Timing Shift with Temperature ¹⁾ $T_{min.} \leq T_{amb} \leq T_{max.}$.5		75		ppm/ $^{\circ}C$
f_{max}	Maximum Astable Frequency ²⁾ $R_A = 470\Omega$, $R_B = 200\Omega$, $C = 200pF$		2		MHz
	Astable Frequency Accuracy ²⁾ $R_A = R_B = 1k\Omega$ to $100k\Omega$, $C = 0.1\mu F$		5		%
	Timing Shift with Supply Voltage Variations (Astable mode) ²⁾ $R_A = R_B = 1k\Omega$ to $100k\Omega$, $C = 0.1\mu F$, $V_{CC} = +3$ to $+5V$		0.5		%/V
t_R	Output Rise Time ($C_{load} = 10pF$)		25		ns
t_F	Output Fall Time ($C_{load} = 10pF$)		20	-	ns
t_{PD}	Trigger Propagation Delay		100		ns
t_{RPW}	Minimum Reset Pulse Width ($V_{trig} = +3V$)		350		ns

1. see figure 2

2. see figure 4

STATIC ELECTRICAL CHARACTERISTICS $V_{CC} = +5V$, $T_{amb} = +25^{\circ}C$, Reset to V_{CC} (unless otherwise specified)

Symbol	Parameter	Min.	Typ.	Max.	Unit
I_{CC}	Supply Current (no load, High and Low States) $T_{min.} \leq T_{amb} \leq T_{max.}$		110	250 250	μA
V_{CL}	Control Voltage Level $T_{min.} \leq T_{amb} \leq T_{max.}$	2.9 2.8	3.3	3.8 3.9	V
V_{DIS}	Discharge Saturation Voltage ($I_{dis} = 10mA$) $T_{min.} \leq T_{amb} \leq T_{max.}$		0.2	0.3 0.35	V
I_{DIS}	Discharge Pin Leakage Current		1	100	nA
V_{OL}	Low Level Output Voltage ($I_{sink} = 8mA$) $T_{min.} \leq T_{amb} \leq T_{max.}$		0.3	0.6 0.8	V
V_{OH}	High Level Output Voltage ($I_{source} = -2mA$) $T_{min.} \leq T_{amb} \leq T_{max.}$	4.4 4.4	4.6		V
V_{TRIG}	Trigger Voltage $T_{min.} \leq T_{amb} \leq T_{max.}$	1.36 1.26	1.67	1.96 2.06	V
I_{TRIG}	Trigger Current		10		μA
I_{TH}	Threshold Current		10		μA
V_{RESET}	Reset Voltage $T_{min.} \leq T_{amb} \leq T_{max.}$	0.4 0.3	1.1	1.5 2.0	V
I_{RESET}	Reset Current		10		μA

DYNAMIC ELECTRICAL CHARACTERISTICS $V_{CC} = +5V$, $T_{amb} = +25^{\circ}C$, Reset to V_{CC} (unless otherwise specified)

Symbol	Parameter	Min.	Typ.	Max.	Unit
	Timing Accuracy (Monostable) ¹⁾ $R = 10k\Omega$, $C = 0.1\mu F$		2		%
	Timing Shift with Supply Voltage Variations (Monostable) ¹⁾ $R = 10k\Omega$, $C = 0.1\mu F$, $V_{CC} = +5V \pm 1V$		0.38		%/V
	Timing Shift with Temperature ¹⁾ $T_{min.} \leq T_{amb} \leq T_{max.}$ ⁵		75		ppm/ $^{\circ}C$
f_{max}	Maximum Astable Frequency ²⁾ $R_A = 470\Omega$, $R_B = 200\Omega$, $C = 200pF$		2.7		MHz
	Astable Frequency Accuracy ²⁾ $R_A = R_B = 1k\Omega$ to $100k\Omega$, $C = 0.1\mu F$		3		%
	Timing Shift with Supply Voltage Variations (Astable mode) ²⁾ $R_A = R_B = 10k\Omega$, $C = 0.1\mu F$, $V_{CC} = +5$ to $+12V$		0.1		%/V
t_R	Output Rise Time ($C_{load} = 10pF$)		25		ns
t_F	Output Fall Time ($C_{load} = 10pF$)		20	-	ns
t_{PD}	Trigger Propagation Delay		100		ns
t_{RPW}	Minimum Reset Pulse Width ($V_{trig} = +5V$)		350		ns

1. see figure 2

2. see figure 4

STATIC ELECTRICAL CHARACTERISTICS

$V_{CC} = +12V$, $T_{amb} = +25^{\circ}C$, Reset to V_{CC} (unless otherwise specified)

Symbol	Parameter	Min.	Typ.	Max.	Unit
I_{CC}	Supply Current (no load, High and Low States) $T_{min.} \leq T_{amb} \leq T_{max.}$		170	400 400	μA
V_{CL}	Control Voltage Level $T_{min.} \leq T_{amb} \leq T_{max.}$	7.4 7.3	8	8.6 8.7	V
V_{DIS}	Discharge Saturation Voltage ($I_{dis} = 80mA$) $T_{min.} \leq T_{amb} \leq T_{max.}$		0.09	1.5 2.0	V
I_{DIS}	Discharge Pin Leakage Current		1	100	nA
V_{OL}	Low Level Output Voltage ($I_{sink} = 50mA$) $T_{min.} \leq T_{amb} \leq T_{max.}$		1.2	2 2.8	V
V_{OH}	High Level Output Voltage ($I_{source} = -10mA$) $T_{min.} \leq T_{amb} \leq T_{max.}$	10.5 10.5	11		V
V_{TRIG}	Trigger Voltage $T_{min.} \leq T_{amb} \leq T_{max.}$	3.2 3.1	4	4.8 4.9	V
I_{TRIG}	Trigger Current		10		μA
I_{TH}	Threshold Current		10		μA
V_{RESET}	Reset Voltage $T_{min.} \leq T_{amb} \leq T_{max.}$	0.4 0.3	1.1	1.5 2.0	V
I_{RESET}	Reset Current		10		μA

DYNAMIC ELECTRICAL CHARACTERISTICS

$V_{CC} = +12V$, $T_{amb} = +25^{\circ}C$, Reset to V_{CC} (unless otherwise specified)

Symbol	Parameter	Min.	Typ.	Max.	Unit
	Timing Accuracy (Monostable) ¹⁾ $R = 10k\Omega$, $C = 0.1\mu F$, $V_{CC} = +12V$		4		%
	Timing Shift with Supply Voltage Variations (Monostable) ¹⁾ $R = 10k\Omega$, $C = 0.1\mu F$, $V_{CC} = +5V \pm 1V$		0.38		%/V
	Timing Shift with Temperature $T_{min.} \leq T_{amb} \leq T_{max.}$, $V_{CC} = +5$		75		ppm/ $^{\circ}C$
f_{max}	Maximum Astable Frequency ²⁾ $R_A = 470\Omega$, $R_B = 200\Omega$, $C = 200pF$, $V_{CC} = +5V$		2.7		MHz
	Astable Frequency Accuracy ²⁾ $R_A = R_B = 1k\Omega$ to $100k\Omega$, $C = 0.1\mu F$, $V_{CC} = +12V$		3		%
	Timing Shift with Supply Voltage Variations (Astable mode) $R_A = R_B = 1k\Omega$ to $100k\Omega$, $C = 0.1\mu F$, $V_{CC} = 5$ to $+12V$		0.1		%/V

1. see figure 2

2. see figure 4

TYPICAL CHARACTERISTICS

Figure 1 : Supply Current (each timer) versus Supply Voltage

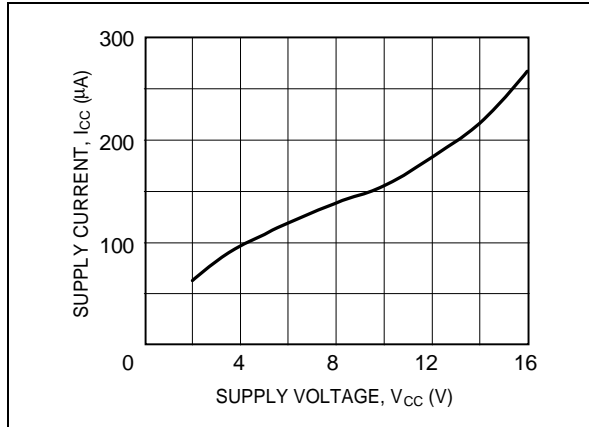

APPLICATION INFORMATION

MONOSTABLE OPERATION

In the monostable mode, the timer operates like a one-shot generator. Referring to figure 2, the external capacitor is initially held discharged by a transistor inside the timer.

Figure 2 :

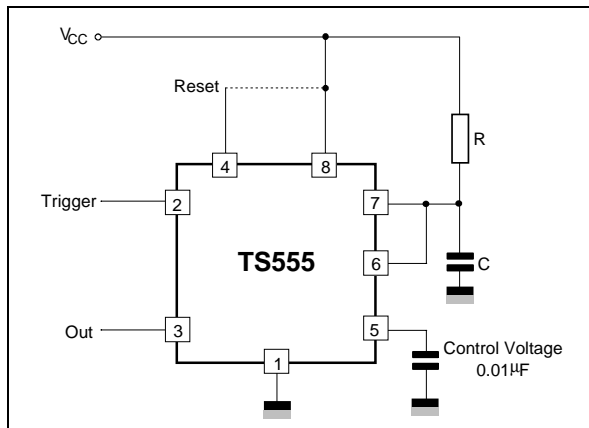

The circuit triggers on a negative-going input signal when the level reaches $1/3 V_{CC}$. Once triggered, the circuit remains in this state until the set time has elapsed, even if it is triggered again during this interval. The duration of the output HIGH state is given by $t = 1.1 R \times C$.

It can be noticed that since the charge rate and the threshold level of the comparator are both directly proportional to the supply voltage, the timing interval is independent of the supply. Applying a negative pulse simultaneously to the Reset terminal (pin 4) and the Trigger terminal (pin 2) during the timing cycle discharges the external capacitor and causes the cycle to start over. The timing cycle now starts on the positive edge of the reset pulse. While the reset pulse is applied, the output is driven to the LOW state.

When a negative trigger pulse is applied to pin 2, the flip-flop is set, releasing the short circuit across the external capacitor and driving the output HIGH. The voltage across the capacitor increases exponentially with the time constant $\tau = R \times C$.

When the voltage across the capacitor equals $2/3 V_{CC}$, the comparator resets the flip-flop which then discharges the capacitor rapidly and drives the output to its LOW state.

Figure 3 shows the actual waveforms generated in this mode of operation.

When Reset is not used, it should be tied high to avoid any possible or false triggering.

Figure 3 :

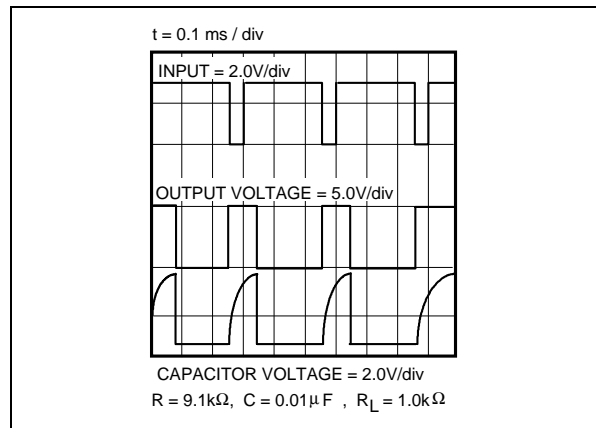

ASTABLE OPERATION

When the circuit is connected as shown in figure 4 (pin 2 and 6 connected) it triggers itself and free runs as a multivibrator. The external capacitor charges through R_A and R_B and discharges through R_B only. Thus the duty cycle may be precisely set by the ratio of these two resistors.

In the astable mode of operation, C charges and discharges between $1/3 V_{CC}$ and $2/3 V_{CC}$. As in the triggered mode, the charge and discharge times and therefore frequency, are independent of the supply voltage.

Figure 4:

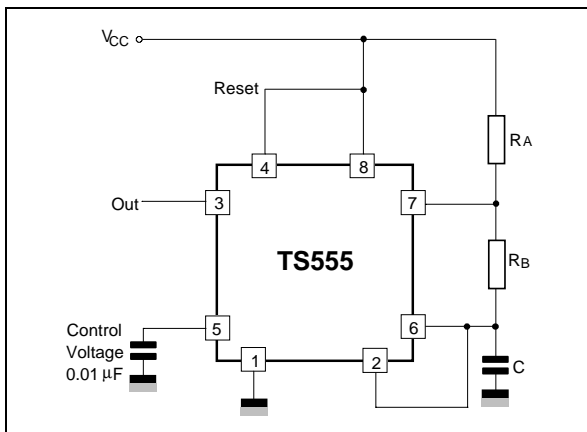

Figure 5 shows actual waveforms generated in this mode of operation.

The charge time (output HIGH) is given by :

$$t1 = 0.693 (R_A + R_B) C$$

and the discharge time (output LOW) by :

$$t2 = 0.693 \times R_B \times C$$

Thus the total period T is given by :

$$T = t1 + t2 = 0.693 (R_A + 2R_B) C$$

The frequency of oscillation is then :

$$f = \frac{1}{T} = \frac{1.44}{(R_A + 2R_B)C}$$

The duty cycle is given by :

$$D = \frac{R_B}{R_A + 2R_B}$$

Figure 5:

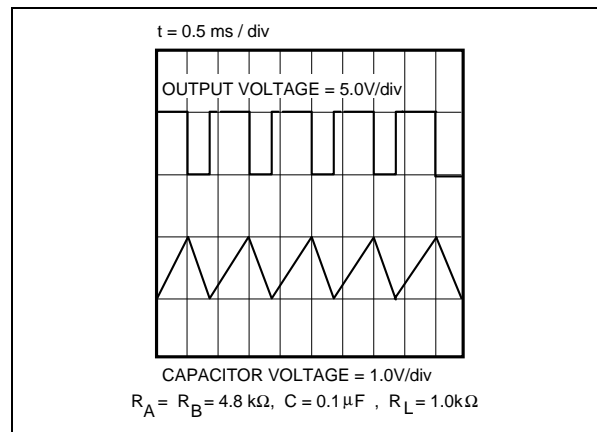

PACKAGE MECHANICAL DATA
8 PINS - PLASTIC DIP

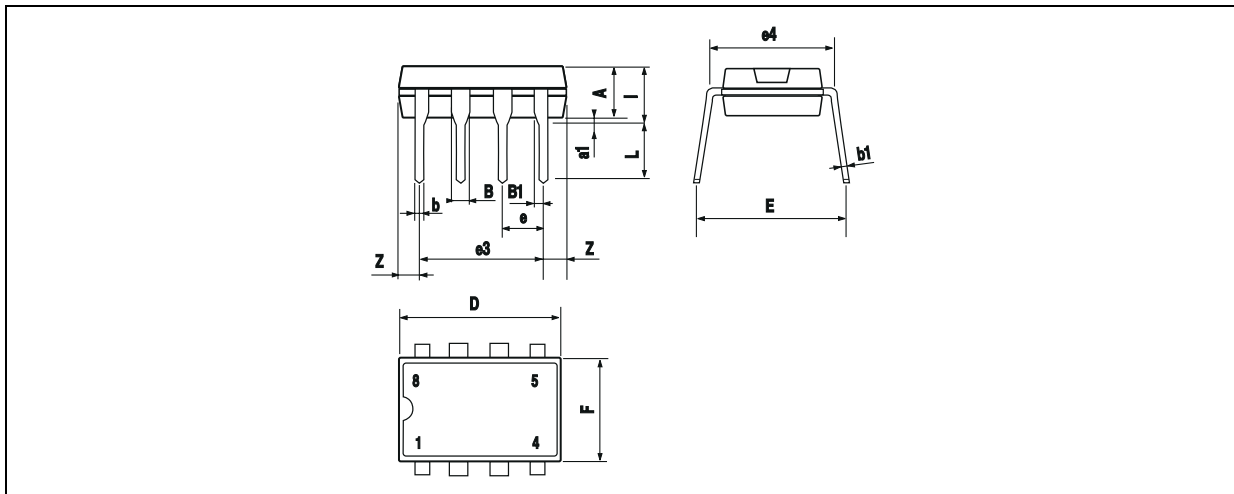

Dimensions	Millimeters			Inches		
	Min.	Typ.	Max.	Min.	Typ.	Max.
A		3.32			0.131	
a1	0.51			0.020		
B	1.15		1.65	0.045		0.065
b	0.356		0.55	0.014		0.022
b1	0.204		0.304	0.008		0.012
D			10.92			0.430
E	7.95		9.75	0.313		0.384
e		2.54			0.100	
e3		7.62			0.300	
e4		7.62			0.300	
F			6.6			0.260
i			5.08			0.200
L	3.18		3.81	0.125		0.150
Z			1.52			0.060

PACKAGE MECHANICAL DATA
8 PINS - PLASTIC MICROPACKAGE (SO)

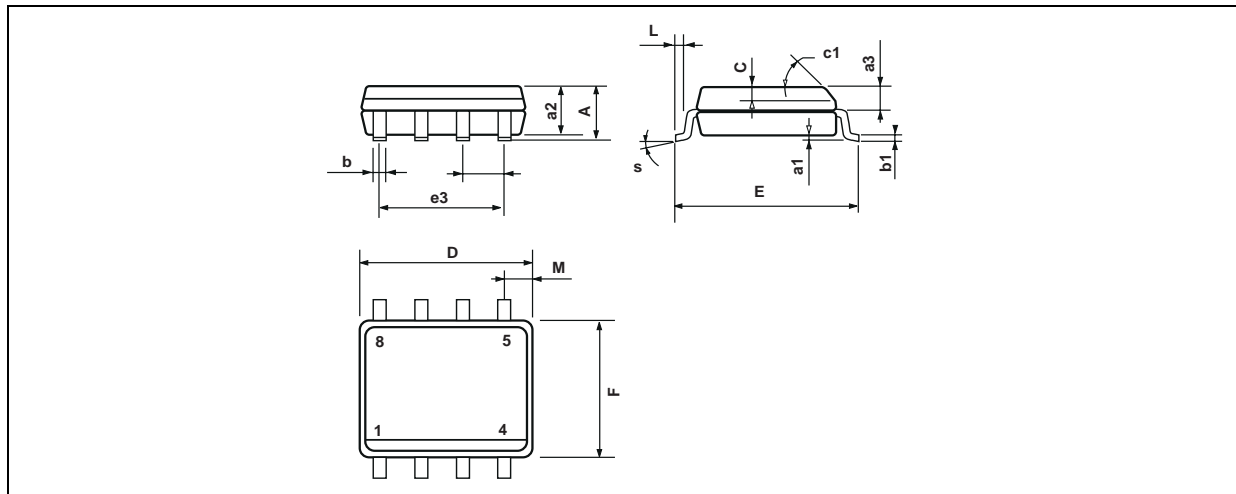

Dimensions	Millimeters			Inches		
	Min.	Typ.	Max.	Min.	Typ.	Max.
A			1.75			0.069
a1	0.1		0.25	0.004		0.010
a2			1.65			0.065
a3	0.65		0.85	0.026		0.033
b	0.35		0.48	0.014		0.019
b1	0.19		0.25	0.007		0.010
C	0.25		0.5	0.010		0.020
c1	45° (typ.)					
D	4.8		5.0	0.189		0.197
E	5.8		6.2	0.228		0.244
e		1.27			0.050	
e3		3.81			0.150	
F	3.8		4.0	0.150		0.157
L	0.4		1.27	0.016		0.050
M			0.6			0.024
S	8° (max.)					

PACKAGE MECHANICAL DATA

8 PINS - THIN SHRINK SMALL OUTLINE PACKAGE

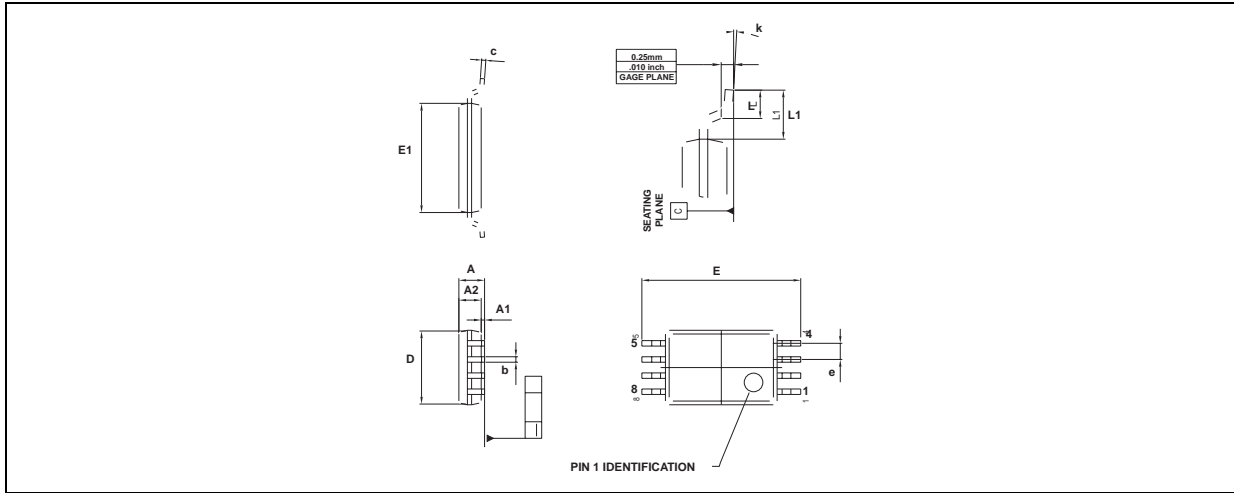

Dimensions	Millimeters			Inches		
	Min.	Typ.	Max.	Min.	Typ.	Max.
A			1.20			0.05
A1	0.05		0.15	0.01		0.006
A2	0.80	1.00	1.05	0.031	0.039	0.041
b	0.19		0.30	0.007		0.15
c	0.09		0.20	0.003		0.012
D	2.90	3.00	3.10	0.114	0.118	0.122
E		6.40			0.252	
E1	4.30	4.40	4.50	0.169	0.173	0.177
e		0.65			0.025	
k	0°		8°	0°		8°
l	0.50	0.60	0.75	0.09	0.0236	0.030
L	0.45	0.600	0.75	0.018	0.024	0.030
L1		1.000			0.039	

Information furnished is believed to be accurate and reliable. However, STMicroelectronics assumes no responsibility for the consequences of use of such information nor for any infringement of patents or other rights of third parties which may result from its use. No license is granted by implication or otherwise under any patent or patent rights of STMicroelectronics. Specifications mentioned in this publication are subject to change without notice. This publication supersedes and replaces all information previously supplied. STMicroelectronics products are not authorized for use as critical components in life support devices or systems without express written approval of STMicroelectronics.

© The ST logo is a registered trademark of STMicroelectronics

© 2003 STMicroelectronics - Printed in Italy - All Rights Reserved
STMicroelectronics GROUP OF COMPANIES

Australia - Brazil - China - Finland - France - Germany - Hong Kong - India - Italy - Japan - Malaysia - Malta - Morocco
 Singapore - Spain - Sweden - Switzerland - United Kingdom

© <http://www.st.com>

