



Chipsmall Limited consists of a professional team with an average of over 10 year of expertise in the distribution of electronic components. Based in Hongkong, we have already established firm and mutual-benefit business relationships with customers from,Europe,America and south Asia,supplying obsolete and hard-to-find components to meet their specific needs.

With the principle of “Quality Parts,Customers Priority,Honest Operation,and Considerate Service”,our business mainly focus on the distribution of electronic components. Line cards we deal with include Microchip,ALPS,ROHM,Xilinx,Pulse,ON,Everlight and Freescale. Main products comprise IC,Modules,Potentiometer,IC Socket,Relay,Connector.Our parts cover such applications as commercial,industrial, and automotives areas.

We are looking forward to setting up business relationship with you and hope to provide you with the best service and solution. Let us make a better world for our industry!



Contact us

Tel: +86-755-8981 8866 Fax: +86-755-8427 6832

Email & Skype: info@chipsmall.com Web: www.chipsmall.com

Address: A1208, Overseas Decoration Building, #122 Zhenhua RD., Futian, Shenzhen, China



FEATURES

- 2 output pads for output loading
- Fully Assembled and Tested
- 2in x 1in 2-layer circuit board

COMPONENT LIST

DESIGNATION	QTY	DESCRIPTION
C2	1	0.1 μ F \pm 10% capacitors (0805)
U1	1	TS6001AIG325 Voltage Reference
VIN, VOUT, GND	4	Test points

DESCRIPTION

The demo board for the TS6001-2.5V is a completely assembled and tested circuit board that can be used for evaluating the TS6001-2.5V voltage reference.

The TS6001-2.5V demo board provides an on-board 0.1 μ F decoupling capacitor at the input. Two pads are available at the output to accommodate a capacitive load and a resistive load. The demo board includes a supply test point with a dedicated ground test point as well as an output test point with a dedicated ground test point.

The TS6001-2.5V is available in a PCB-space saving 3-lead SOT23 surface-mount package.

Product data sheets and additional documentation can be found at www.silabs.com.

ORDERING INFORMATION

Order Number	Description
TS6001G3-2.5DB	Demo Board

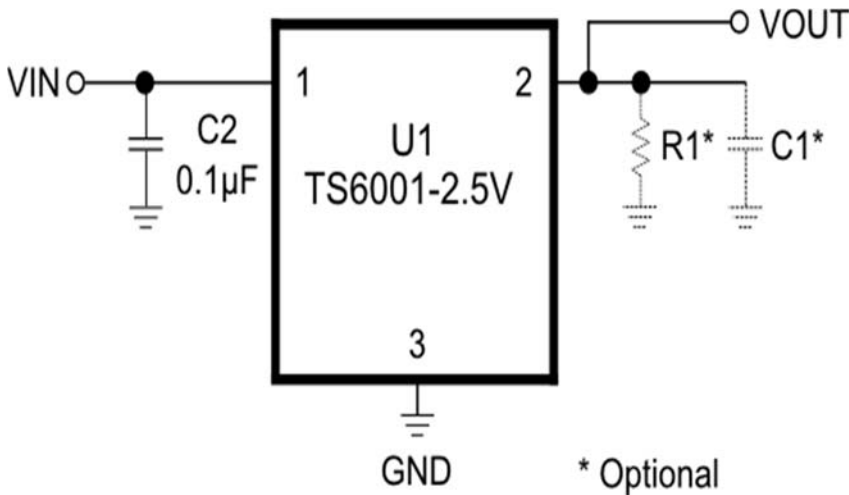

Figure 1. TS6001 Evaluation Board Circuit



Figure 2. TS6001 Evaluation Board

DESCRIPTION

The demo board provides an on-board 0.1 μ F decoupling capacitor at the VIN input. Two pads are available at the output to accommodate a capacitive load and a resistive load as needed.

QUICK START PROCEDURES

Required Equipment

- TS6001DB demo board
- A DC Power Supply, Single, an HP Model HP6624A or equivalent
- A digital voltmeter, an HP34410A or equivalent
- A digital ammeter, an HP34410A or equivalent

To evaluate the TS6001 voltage reference, the following steps are to be performed:

- 1) Before connecting the DC power supply to the demo board, turn on the power supply and set the DC voltage to 5V and then turn it off.
- 2) Connect the DC power supply positive terminal to the negative terminal of the digital ammeter. Then, connect the positive terminal of the ammeter to the test point VIN and the negative terminal of the DC power supply to the adjacent test point GND.

- 3) Connect the positive terminal of the digital voltmeter to test point VOUT and the negative terminal to the adjacent test point GND.
- 4) An optional load resistor $\geq 5k\Omega$ and capacitor up to 2200pF can be soldered on the board. Solder the resistor on pads R1 and the capacitor on pads C1. If a load is not desired, leave these pads open and proceed to step 5.
- 5) Turn on the power supply and check that the digital voltmeter is reading an output voltage within $\pm 0.2\%$ of 2.5V and the digital ammeter is reading a supply current less than 35 μ A.
- 6) The input voltage VIN can vary from VOUT + 0.2V to 12.6V as needed. Please refer to the TS6001 product datasheet “Electrical Characteristics” section for more information.

Note: In order to add a Kelvin connection to the output test point VOUT, connect the positive terminal of a DVM to VOUT and the negative terminal to GND. Then, place a resistor and/or capacitor on pads R1 and/or pads C1, respectively. For an accurate VOUT measurement, always connect the positive terminal of the DVM to the VOUT test point.

If additional loading is needed on the output VOUT, a wire can be soldered on pads R1 and C1. Then, a load can be connected to the other end of the wire. Make sure the load is connected to the ground on the board.

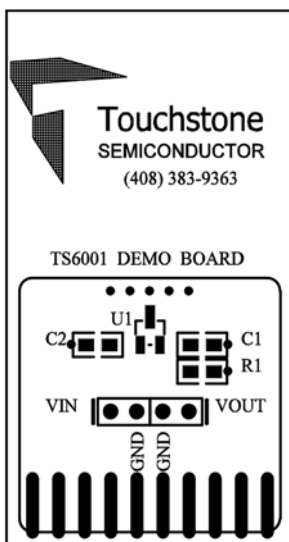

Figure 3. Top Layer Component View

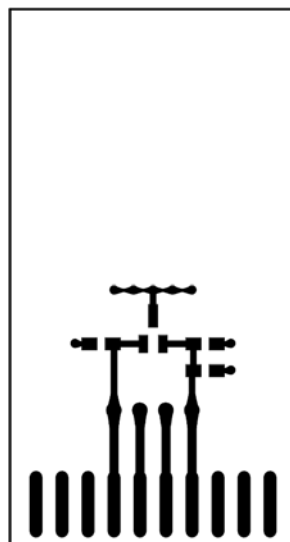
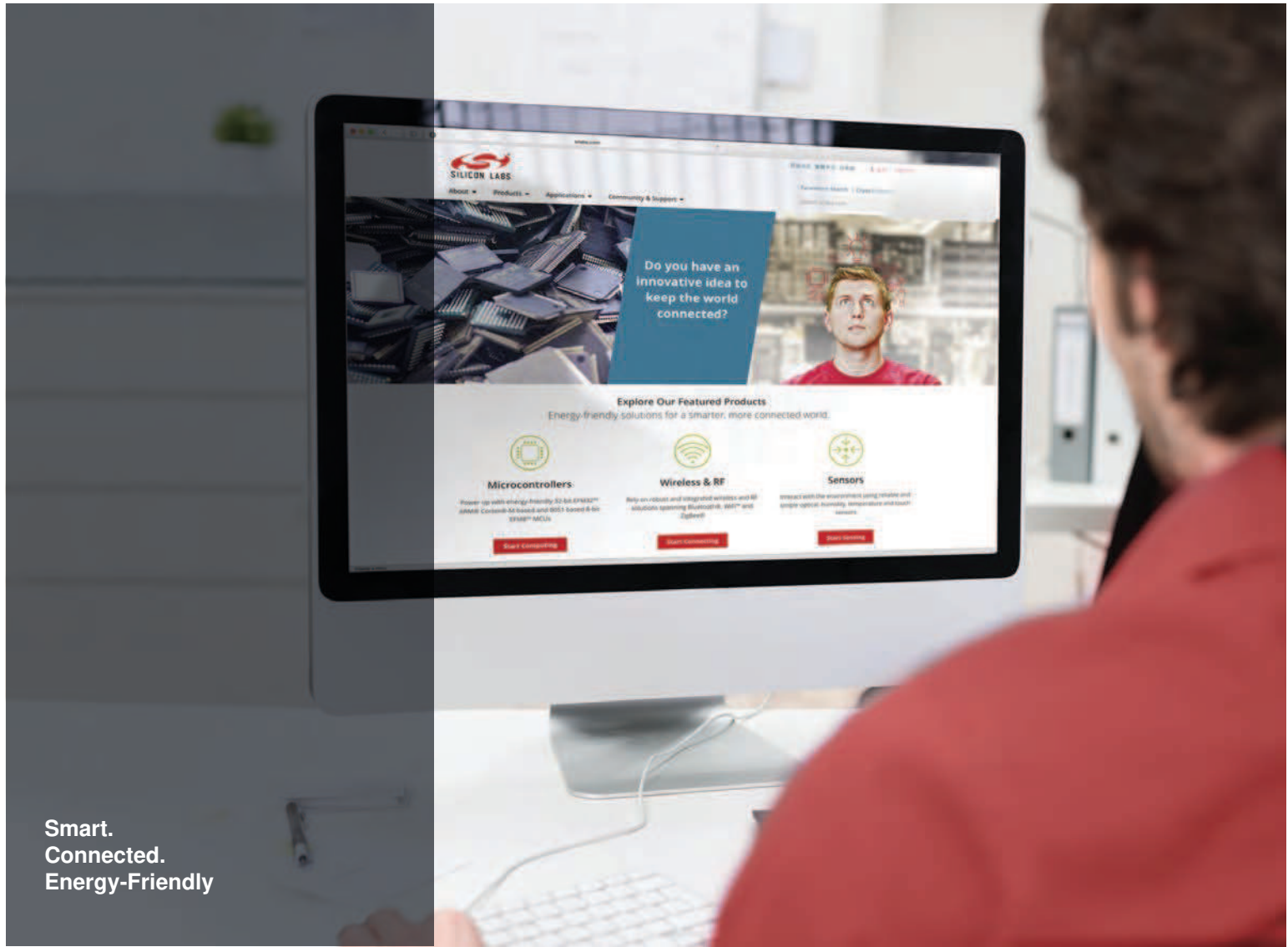

Figure 4. Top Layer Trace View



Figure 5. Bottom layer (GND)



Smart.
Connected.
Energy-Friendly



Products
www.silabs.com/products

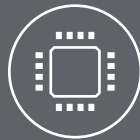

Quality
www.silabs.com/quality



Support and Community
community.silabs.com

Disclaimer

Silicon Laboratories intends to provide customers with the latest, accurate, and in-depth documentation of all peripherals and modules available for system and software implementers using or intending to use the Silicon Laboratories products. Characterization data, available modules and peripherals, memory sizes and memory addresses refer to each specific device, and "Typical" parameters provided can and do vary in different applications. Application examples described herein are for illustrative purposes only. Silicon Laboratories reserves the right to make changes without further notice and limitation to product information, specifications, and descriptions herein, and does not give warranties as to the accuracy or completeness of the included information. Silicon Laboratories shall have no liability for the consequences of use of the information supplied herein. This document does not imply or express copyright licenses granted hereunder to design or fabricate any integrated circuits. The products must not be used within any Life Support System without the specific written consent of Silicon Laboratories. A "Life Support System" is any product or system intended to support or sustain life and/or health, which, if it fails, can be reasonably expected to result in significant personal injury or death. Silicon Laboratories products are generally not intended for military applications. Silicon Laboratories products shall under no circumstances be used in weapons of mass destruction including (but not limited to) nuclear, biological or chemical weapons, or missiles capable of delivering such weapons.

Trademark Information

Silicon Laboratories Inc., Silicon Laboratories, Silicon Labs, SiLabs and the Silicon Labs logo, CMEMS®, EFM, EFM32, EFR, Energy Micro, Energy Micro logo and combinations thereof, "the world's most energy friendly microcontrollers", Ember®, EZLink®, EZMac®, EZRadio®, EZRadioPRO®, DSPLL®, ISOmodem®, Precision32®, ProSLIC®, SiPHY®, USBXpress® and others are trademarks or registered trademarks of Silicon Laboratories Inc. ARM, CORTEX, Cortex-M3 and THUMB are trademarks or registered trademarks of ARM Holdings. Keil is a registered trademark of ARM Limited. All other products or brand names mentioned herein are trademarks of their respective holders.



SILICON LABS

Silicon Laboratories Inc.
400 West Cesar Chavez
Austin, TX 78701
USA

<http://www.silabs.com>