



Chipsmall Limited consists of a professional team with an average of over 10 year of expertise in the distribution of electronic components. Based in Hongkong, we have already established firm and mutual-benefit business relationships with customers from,Europe,America and south Asia,supplying obsolete and hard-to-find components to meet their specific needs.

With the principle of “Quality Parts,Customers Priority,Honest Operation,and Considerate Service”,our business mainly focus on the distribution of electronic components. Line cards we deal with include Microchip,ALPS,ROHM,Xilinx,Pulse,ON,Everlight and Freescale. Main products comprise IC,Modules,Potentiometer,IC Socket,Relay,Connector.Our parts cover such applications as commercial,industrial, and automotives areas.

We are looking forward to setting up business relationship with you and hope to provide you with the best service and solution. Let us make a better world for our industry!



Contact us

Tel: +86-755-8981 8866 Fax: +86-755-8427 6832

Email & Skype: info@chipsmall.com Web: www.chipsmall.com

Address: A1208, Overseas Decoration Building, #122 Zhenhua RD., Futian, Shenzhen, China



Linear Constant Current Regulated LED Driver

DESCRIPTION

The TSCR400 & TSCR402 are High-Side Constant Current Regulator (CCR) for linear LED driving. The device regulates with a preset TSCR400 0.1mA and TSCR402 20mA nominal that can be adjusted with an external resistor up to 65mA. It is designed for driving LEDs in strings and will reduce current at increasing temperatures to self-protect. Operating as a series linear CCR for LED string current control, it can be used in multiple applications, as long as the maximum supply voltage to the device is <40V.

The output current at higher temperatures is the result of the negative temperature coefficient of -0.07%/°C of the LED driver.

FEATURES

- LED drive current preset:
 - TSCR400CX6: 0.1mA
 - TSCR402CX6: 20mA
- Continuous output current up to 65mA with an external resistor
- Easy paralleling of drivers to increase current
- Supply voltage up to 40V
- Good temperature coefficient vs. output current
- Compliant to RoHS Directive 2011/65/EU and in accordance to WEEE 2002/96/EC.
- Halogen-Free according to IEC 61249-2-21

APPLICATION

- Automotive Interior Lighting
- Architectural LED lighting
- Signage, Advertising, Decorative Lighting
- Retail Lighting in Fridges, Freezer Cases and Vending Machines
- Emergency lighting (e.g. steps lighting, exit way signs etc.)



SOT-26

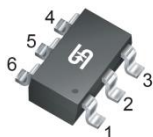

Pin Definition:

- | | |
|--------|---------------------|
| 1. GND | 6. R _{EXT} |
| 2. OUT | 5. OUT |
| 3. OUT | 4. V _S |

Notes: MSL 1 (Moisture Sensitivity Level) per J-STD-020

TYPICAL APPLICATION CIRCUIT

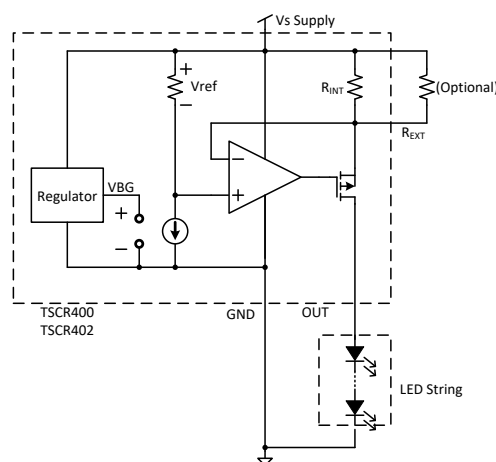

ABSOLUTE MAXIMUM RATINGS ($T_A = 25^\circ\text{C}$ unless otherwise specified) ^(Note 1)			
PARAMETER	SYMBOL	LIMIT	UNIT
Supply Voltage	V_S	40	V
Output Current	I_{OUT}	65	mA
Output Voltage	V_{OUT}	38	V
Reverse voltage between all terminals	V_R	0.5	V
Total power dissipation @ $T_A=25^\circ\text{C}$ ^(Note)	P_{TOT}	1	W
Junction Temperature Range	T_J	-55 to +150	$^\circ\text{C}$
Storage Temperature Range	T_{STG}	-65 to +150	$^\circ\text{C}$
ESD Rating (Human Body Mode)	HBM	2	kV
ESD Rating (Machine Mode)	MM	200	V

Note:

Stresses above the max. values listed here may cause permanent damage to the device. Exposure to absolute maximum rating conditions for extended periods may affect device reliability. Maximum ratings are absolute ratings; exceeding only one of these values may cause irreversible damage to the integrated circuit.

THERMAL PERFORMANCE			
PARAMETER	SYMBOL	LIMIT	UNIT
Thermal Resistance - Junction to Lead	$R_{\theta JL}$	50	$^\circ\text{C}/\text{W}$

ELECTRICAL SPECIFICATIONS ($T_A = 25^\circ\text{C}$ unless otherwise noted)							
PARAMETER	CONDITIONS		SYMBOL	MIN	TYP	MAX	UNIT
Break Down Voltage			V_{BR}	40	--	--	V
Supply Current	TSCR400	$V_S=3\text{V}$	I_S	--	60	--	μA
	TSCR402	$V_S=10\text{V}$		--	150	--	μA
Internal Resistor	TSCR400	$I_{RINT}=0.1\text{mA}$	R_{INT}	5.85	6.5	7.15	k Ω
	TSCR402	$I_{RINT}=20\text{mA}$		38	44	52	Ω
Output Current	TSCR400	$V_S=3\text{V}$	I_{OUT}	0.085	0.1	0.115	mA
	TSCR402	$V_S=10\text{V}, V_{OUT}=8.6\text{V}$		18	20	22	
Voltage Drop ($V_S - V_{REXT}$)	TSCR400	$I_{OUT}=1\text{mA}$	V_{DROP}	--	0.65	--	V
	TSCR402	$I_{OUT}=20\text{mA}$		--	0.85	--	
Lowest Sufficient Battery Voltage	TSCR400	$I_{OUT}>85\mu\text{A}$	V_{Smin}	--	1.6	--	V
	TSCR402	$I_{OUT}>18\text{mA}$		--	1.4	--	
Output Current vs. Temperature	TSCR400	$V_S=3\text{V}$	$\Delta I_{OUT}/I_{OUT}$	--	-0.07	--	%/ $^\circ\text{C}$
	TSCR402	$V_S=10\text{V}$		--	-0.07	--	
Output Current vs. Supply Voltage	TSCR400	$V_S=3\text{V}$	$\Delta I_{OUT}/I_{OUT}$	--	0.33	--	%/ V
	TSCR402	$V_S=10\text{V}$		--	0.33	--	

ORDERING INFORMATION

PART NO.	PACKAGE	PACKING
TSCR400CX6 RFG	SOT-26	3,000pcs / 7"Reel
TSCR402CX6 RFG	SOT-26	3,000pcs / 7"Reel

FUNCTION BLOCK

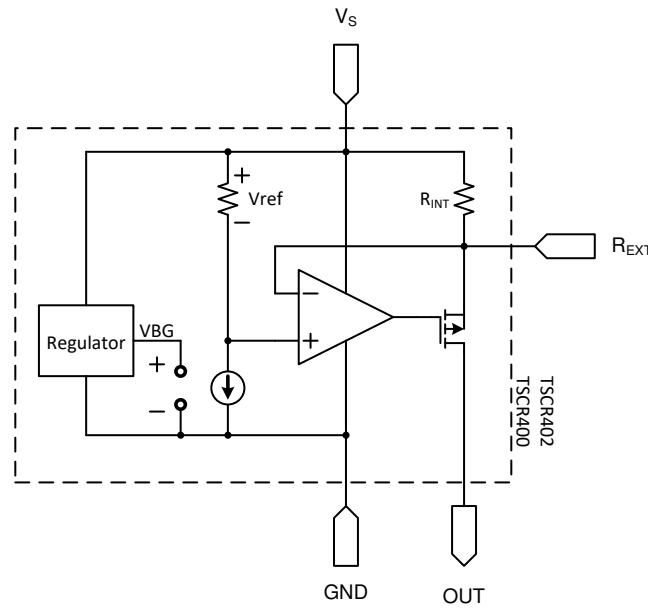

PIN DESCRIPTION

PIN NO.	NAME	FUNCTION
1	GND	Power ground
2	OUT	Regulated output current
3	OUT	Regulated output current
4	V_s	Supply voltage
5	OUT	Regulated output current
6	R_{EXT}	External resistor for adjusting output current

TSCR400CX6 CHARACTERISTICS CURVES

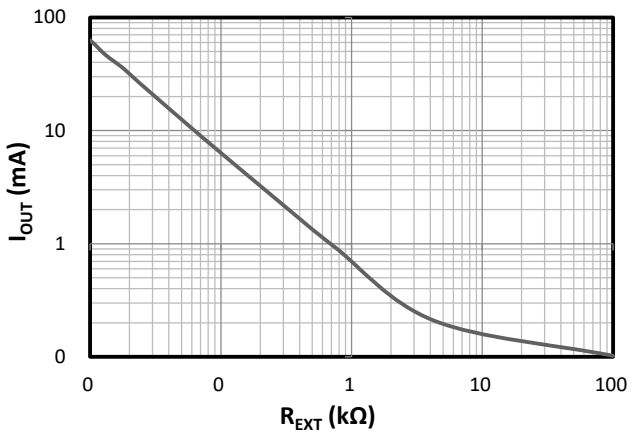

Figure 1. I_{OUT} vs. R_{EXT}

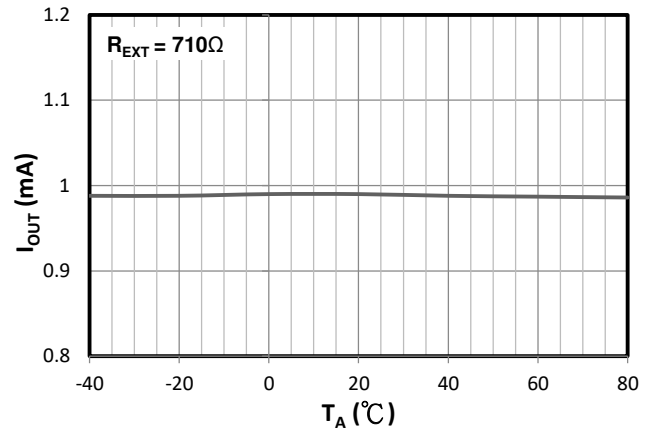

Figure 2. I_{OUT} vs. T_A ($R_{EXT}=710\Omega$)

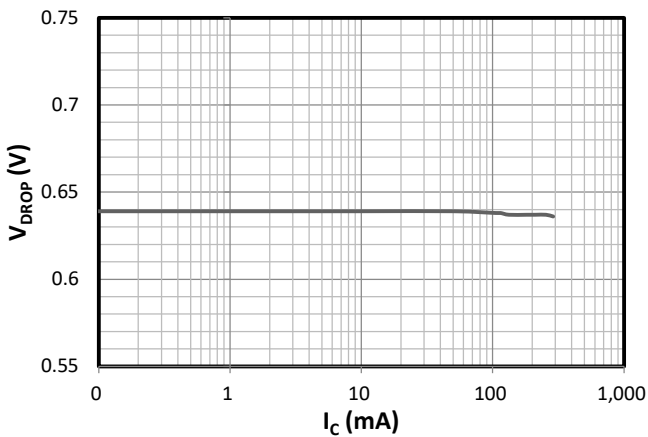

Figure 3. V_{DROP} vs I_C
 $V_{DROP} = f(I_C)$ refer to stabilized NPN Transistor

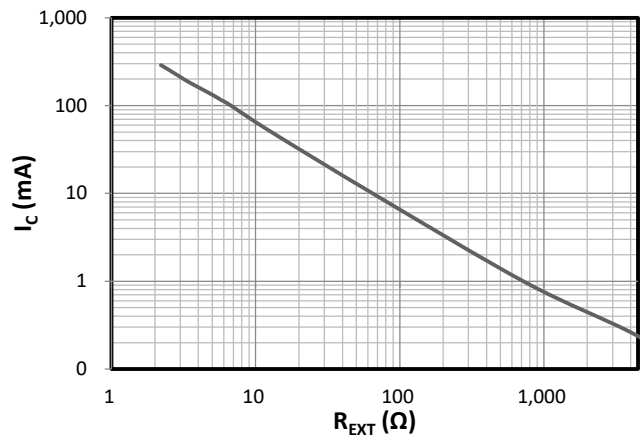

Figure 4. V_{EN} vs I_{OUT} ($R_{EXT}=open$)
Collector Current $I_C = f(R_{EXT})$ refer to stabilized NPN Transistor

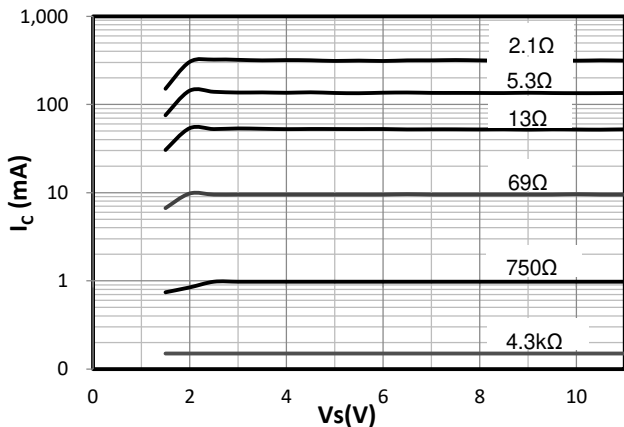

Figure 5. I_C vs. V_S (Parameter $R_{EXT}=(\Omega)$)
Collector Current $I_C = f(V_S)$ refer to stabilized NPN Transistor

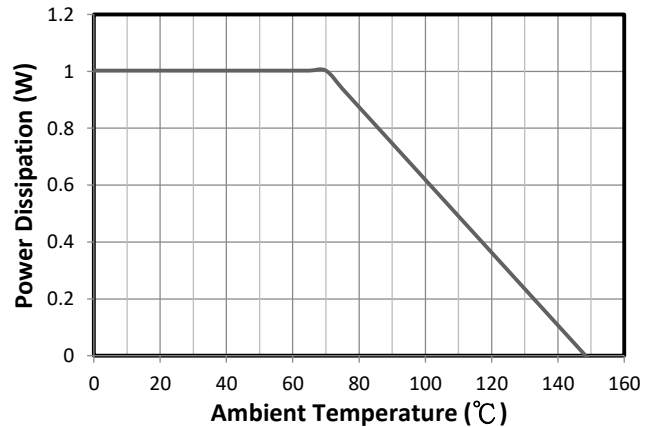

Figure 6. P_D vs. Ambient Temperature

TSCR402CX6 CHARACTERISTICS CURVES

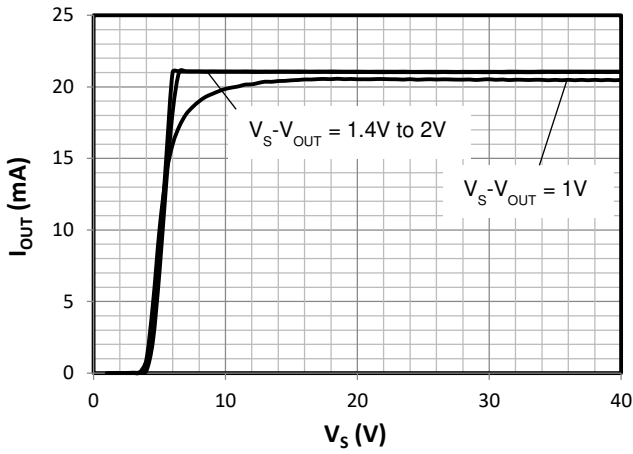

Figure 7. V_S vs. I_{OUT}

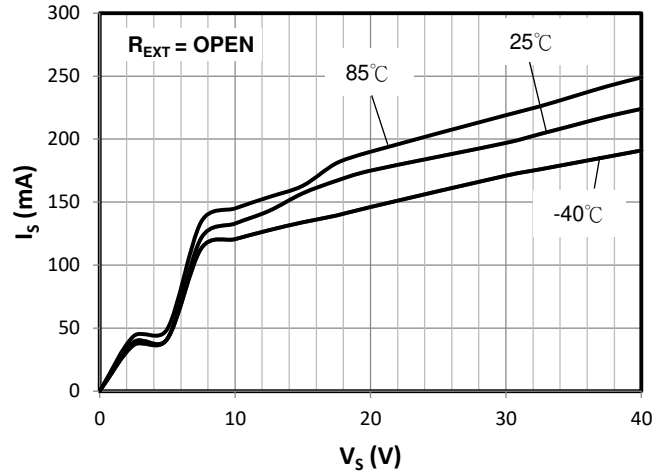

Figure 8. V_S vs. I_S ($R_{EXT}=OPEN$)

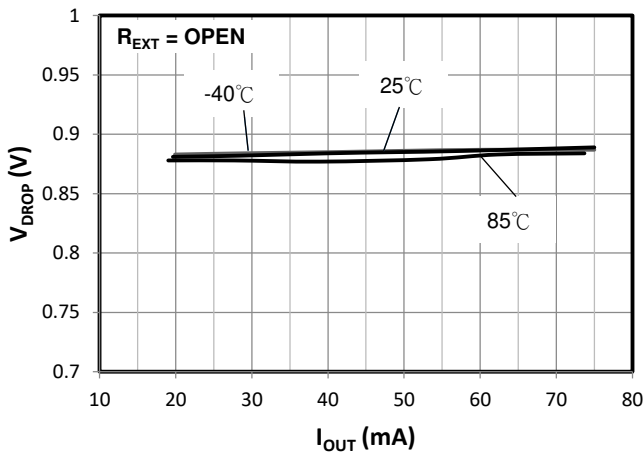

Figure 9. I_{OUT} vs. V_{DROP} ($R_{EXT}=OPEN$)

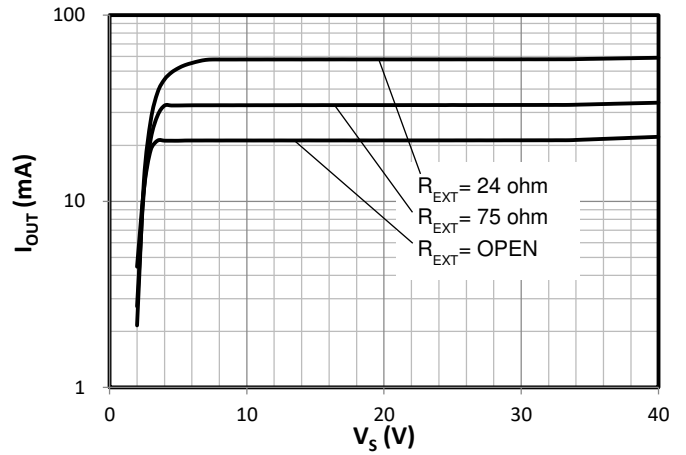

Figure 10. V_S vs. I_{OUT}

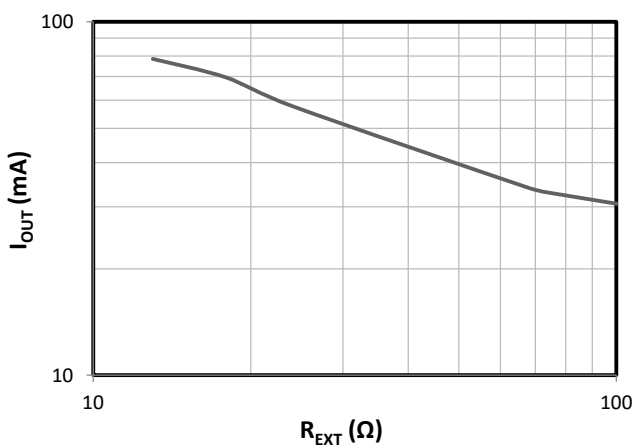

Figure 11. R_{EXT} vs. I_{OUT}

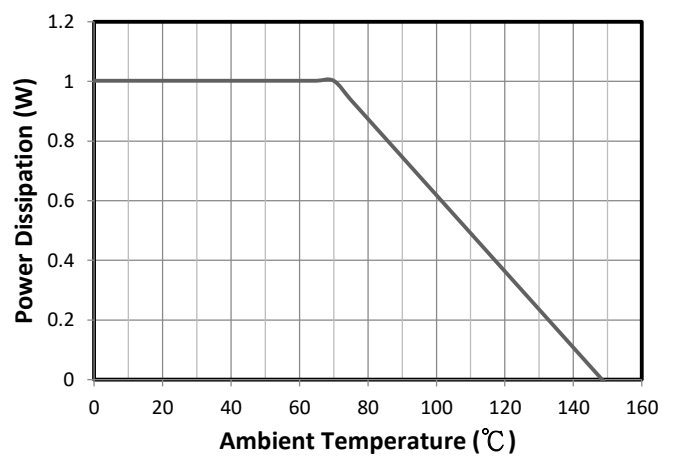

Figure 12. P_D vs. Ambient Temperature

APPLICATION INFORMATION

The TSCR400 & TSCR402 are designed for driving low current LEDs with typical LED currents of 0.1mA to 65mA. They provide a cost-effective way for driving low current LEDs compared with more complex switching regulator solutions. Furthermore, they reduce the PCB board area of the solution as there is no need for external components like inductors, capacitors and switching diodes

Figure 13 shows circuit diagram for stand along application an external resistor R_{EXT} can be connected to adjust the current. The device comes with an internal resistor (R_{INT}) of typically 6.5k Ω and 44 Ω which in the absence of an external resistor, sets an LED current of 0.1mA (typical) for TSCR400 and 20mA (typical) for TSCR402. LED current can be increased to a desired value by choosing an appropriate external resistor, R_{EXT} .

$$R_{EXT} = V_{DROP} / (I_{OUT} - (V_{DROP}/R_{INT}))$$

Figure 14 shows boost mode configuration of LED current can be extended to drive high power LEDs

The R_{EXT} vs I_{LED} graphs should be used to select the appropriate resistor. Choosing a low tolerance R_{EXT} will improve the overall accuracy of the current sense formed by the parallel connection of R_{INT} and R_{EXT} .

$$R_{EXT} = V_{DROP} / (I_{LED} - (V_{DROP}/R_{INT}))$$

Consideration of the expected linear mode power dissipation must be factored into the design, with respect to the TSCR400 & TSCR402's thermal resistance. The maximum voltage across the device can be calculated by taking the maximum supply voltage and subtracting the voltage across the LED string.

$$V_{DEVICE} = V_S - V_{LED}$$

$$P_D = (V_{DEVICE} \times I_{LED}) + (V_S \times I_{GND})$$

As the output current of TSCR400 & TSCR402 increases, it is necessary to provide appropriate thermal relief to the device. The power dissipation supported by the device is dependent upon the PCB board material, the copper area and the ambient temperature. The maximum dissipation the device can handle is given by:

$$P_D = (T_{J(MAX)} - T_A) / R_{\theta JA}$$

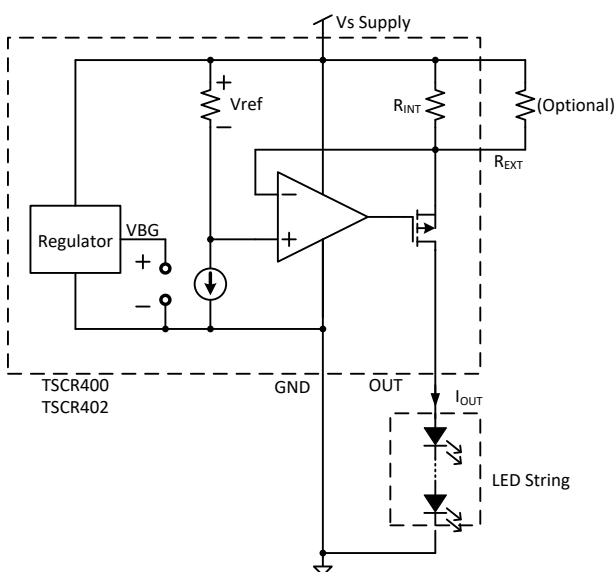

Figure 13: Application circuit for Stand along current source

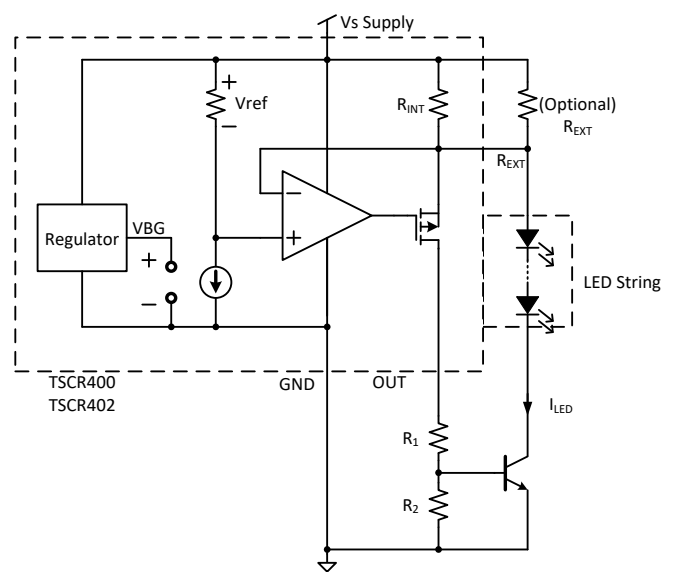
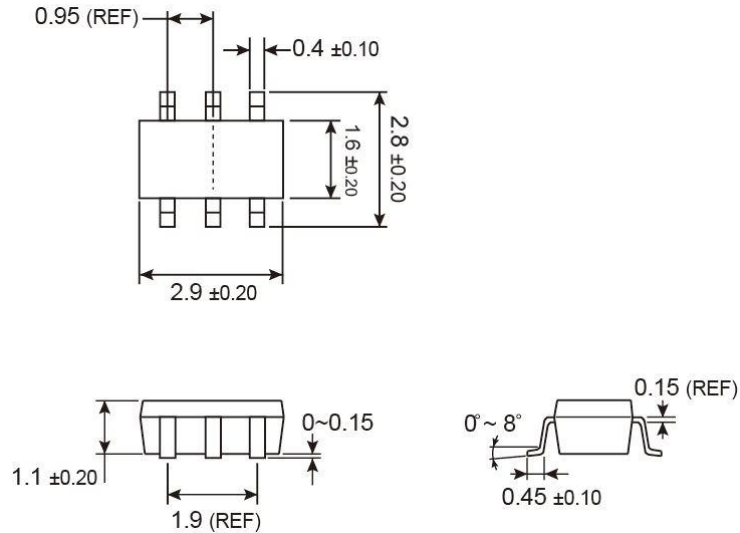

Figure 14: Application Circuit for Boost mode current source with external power transistor

PACKAGE OUTLINE DIMENSIONS (Unit: Millimeters)

SOT-26



SUGGESTED PAD LAYOUT (Unit: Millimeters)

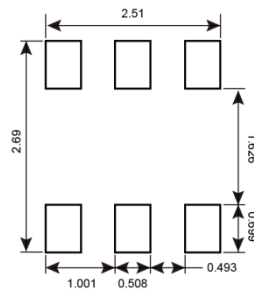

MARKING DIAGRAM

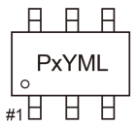

- Px** = Device Code
 - P1 =TSCR400CX6
 - P2 =TSCR402CX6
- Y** = Year Code
- M** = Month Code for Halogen Free Product
 - O** =Jan **P** =Feb **Q** =Mar **R** =Apr
 - S** =May **T** =Jun **U** =Jul **V** =Aug
 - W** =Sep **X** =Oct **Y** =Nov **Z** =Dec
- L** = Lot Code (1~9, A~Z)

Notice

Specifications of the products displayed herein are subject to change without notice. TSC or anyone on its behalf, assumes no responsibility or liability for any errors or inaccuracies.

Information contained herein is intended to provide a product description only. No license, express or implied, to any intellectual property rights is granted by this document. Except as provided in TSC's terms and conditions of sale for such products, TSC assumes no liability whatsoever, and disclaims any express or implied warranty, relating to sale and/or use of TSC products including liability or warranties relating to fitness for a particular purpose, merchantability, or infringement of any patent, copyright, or other intellectual property right.

The products shown herein are not designed for use in medical, life-saving, or life-sustaining applications. Customers using or selling these products for use in such applications do so at their own risk and agree to fully indemnify TSC for any damages resulting from such improper use or sale.