



Chipsmall Limited consists of a professional team with an average of over 10 year of expertise in the distribution of electronic components. Based in Hongkong, we have already established firm and mutual-benefit business relationships with customers from,Europe,America and south Asia,supplying obsolete and hard-to-find components to meet their specific needs.

With the principle of “Quality Parts,Customers Priority,Honest Operation,and Considerate Service”,our business mainly focus on the distribution of electronic components. Line cards we deal with include Microchip,ALPS,ROHM,Xilinx,Pulse,ON,Everlight and Freescale. Main products comprise IC,Modules,Potentiometer,IC Socket,Relay,Connector.Our parts cover such applications as commercial,industrial, and automotives areas.

We are looking forward to setting up business relationship with you and hope to provide you with the best service and solution. Let us make a better world for our industry!



Contact us

Tel: +86-755-8981 8866 Fax: +86-755-8427 6832

Email & Skype: info@chipsmall.com Web: www.chipsmall.com

Address: A1208, Overseas Decoration Building, #122 Zhenhua RD., Futian, Shenzhen, China





TSIxxB1

Application Specific Discretes
A.S.D.™

TERMINAL SET INTERFACE PROTECTION AND DIODE BRIDGE

MAIN APPLICATION

Telecom equipment requiring combined protection against transient overvoltages and rectification by diode bridge :

- Telephone set
- Base station for cordless set
- Fax machine
- Modem
- Caller Id equipment
- Set top box

DESCRIPTION

The TSIxxB1 provides the diode bridge and the crowbar protection function that can be found in most of telecom terminal equipment.

Integrated monolithically within a SO-8 package, this ASD™ device allows space saving on the board and greater reliability.

FEATURES

- STAND-OFF VOLTAGE FROM 62V TO 265V
- PEAK PULSE CURRENT : 30 A (10/1000 μ s)
- MAXIMUM DC CURRENT : $I_F = 0.2$ A
- HOLDING CURRENT : 150 mA

IN ACCORDANCE WITH THE FOLLOWING STANDARDS :

CCITT K17 - K20	10/700 μ s	1.5 kV
	5/310 μ s	38A
VDE 0433	10/700 μ s	2 kV
	5/310 μ s	40A(*)
CNET	0.5/700 μ s	1.5 kV
	0.2/310 μ s	38A
Bellcore TR-NWT-000974:	10/1000 μ s	1 kV
	10/1000 μ s	30A(*)
FCC Part 68	2/10 μ s	2.5 kV
	2/10 μ s	75A (*)

MIL STD883C Method 3015-6

(*) with series resistor or PTC.

TM: ASD is trademarks of STMicroelectronics.

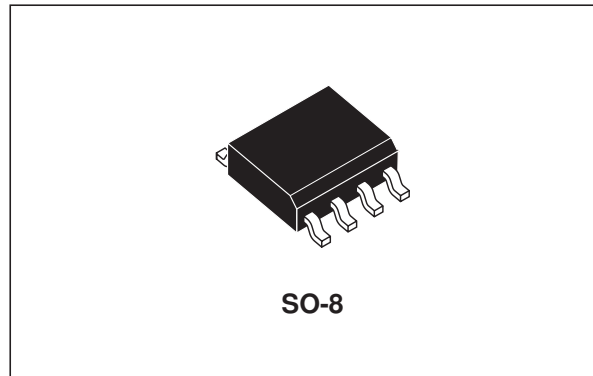

SCHEMATIC DIAGRAM

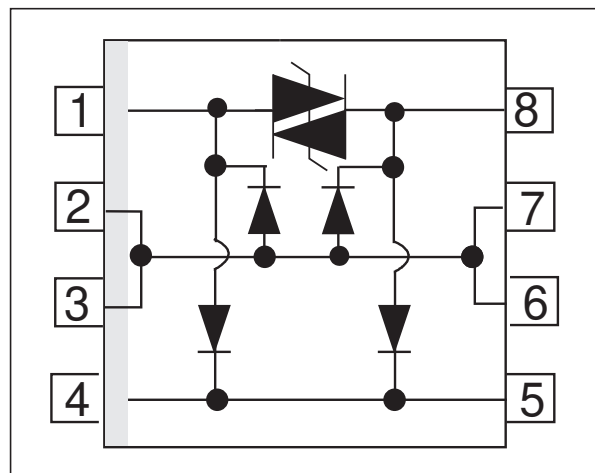

BENEFITS

- Diode bridge for polarity guard and crowbar protection within one device.
- Single chip for greater reliability
- Reduces component count versus discrete solution
- Saves space on the board

TSIxxB1

TYPICAL APPLICATION

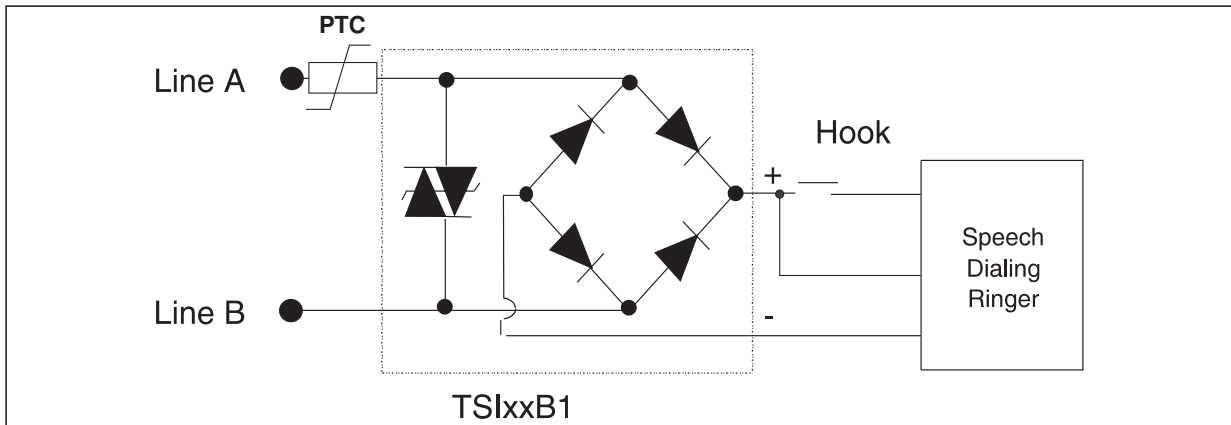

Telecom terminals have a diode bridge for polarity guard, located at the line interface stage. They also have above this diode bridge one crowbar protection device that is mandatory to prevent atmospheric effects and AC mains disturbances from damaging the electronic circuitry that follows the diode bridge.

ST proposes a one chip device that includes both protection and diode bridge. This is the concept of the TSIxxB1 devices.

Fig. 1 : The various uses of the TSIxxB1 in a conventional telecom network

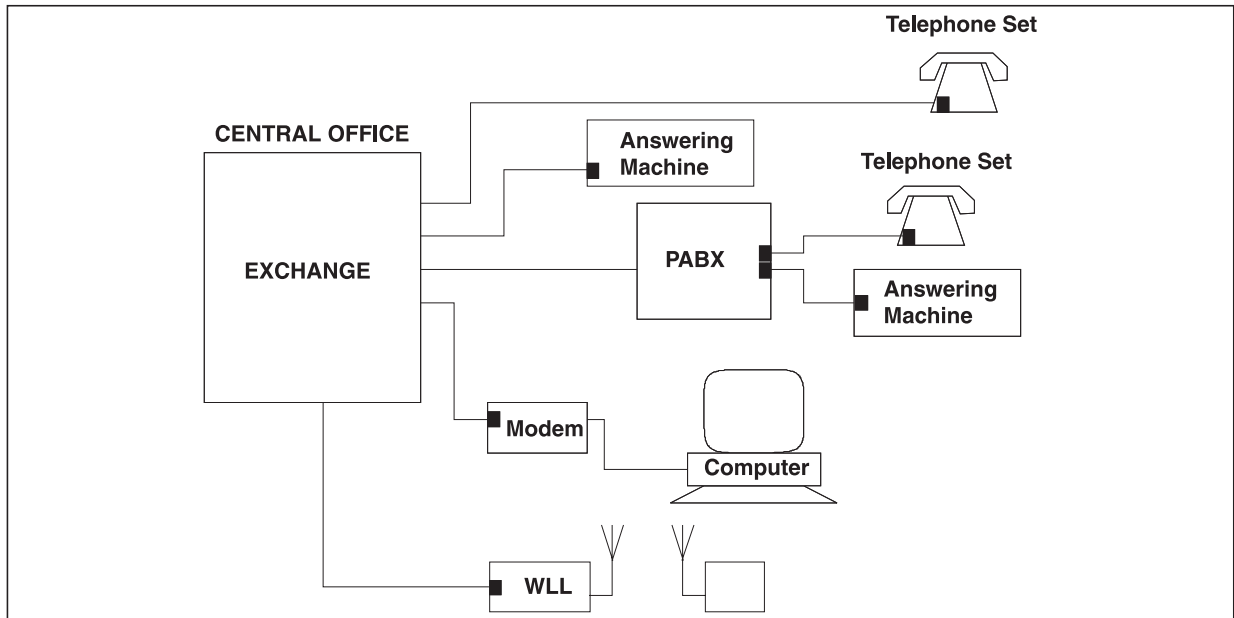

ELECTRICAL PARAMETERS

The V_{RM} value corresponds to the maximum voltage of the application in normal operation. For instance, if the maximum line voltage is ranging between (100V_{RMS} of ringing plus 48V of battery voltage), then the protection chosen for this application shall have a V_{RM} close to 200V.

The V_{BO} is the triggering voltage. This indicates the voltage limit for which the component short-circuits. Passing this V_{BO} makes the device turn on.

The I_{BO} is the current that makes the device turn on. Indeed, if we want a Trisil to be turned on not only the voltage across it shall pass the V_{BO} value but the current through it shall also pass the I_{BO} value.

In other words, if a voltage surge occurring on the line is higher than the V_{BO} value of a Trisil, whereas the line surge current is limited to a value that does not exceed the Trisil's I_{BO} value, then the Trisil will never turn into short circuit. At this time the surge will be clamped by the Trisil.

Anyhow the electronic circuitry located after the Trisil will always be protected whatever the Trisil state is (crowbar or clamping mode).

The I_H stands for the holding current. When the Trisil is turned on, as soon as the crossing current surge gets lower than this I_H value, the Trisil protection device turns back in its idle state.

Remark : for this reason the Trisil 's I_H value shall be chosen higher than what the maximum telecom line current can be.

TSIxXB1 BEHAVIOUR WITH REGARD TO SURGE STANDARD :

The TSIxXB1 is able to replace both diode bridge and usual discrete protection on telecom terminals. Furthermore it complies with the CCITT K17 recommendations :

- 10/700 μ s waveform surge test, (1.5kV
- AC power induction test
- AC power contact test

Fig. 2 : Test circuit for the CCITT K17 recommendations

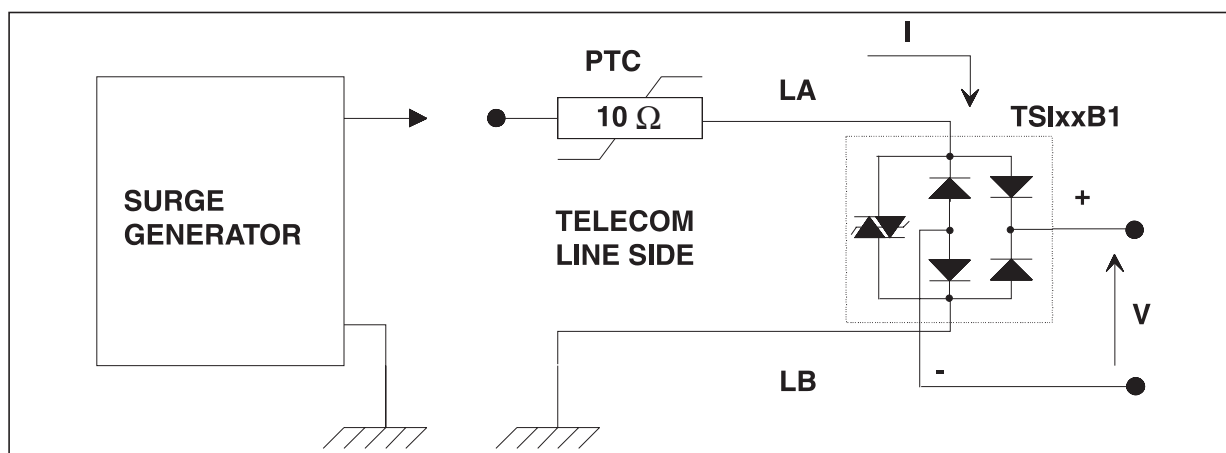

TSIxxB1

TEST # 1 LIGHTNING SIMULATION

This test concerns the 10/700 μs waveform surge, $\pm 1.5 \text{ kV}$.

The surge generator used for the test has the following circuitry (fig.2).

Fig. 2 : 10/700 μs waveform surge generator circuit

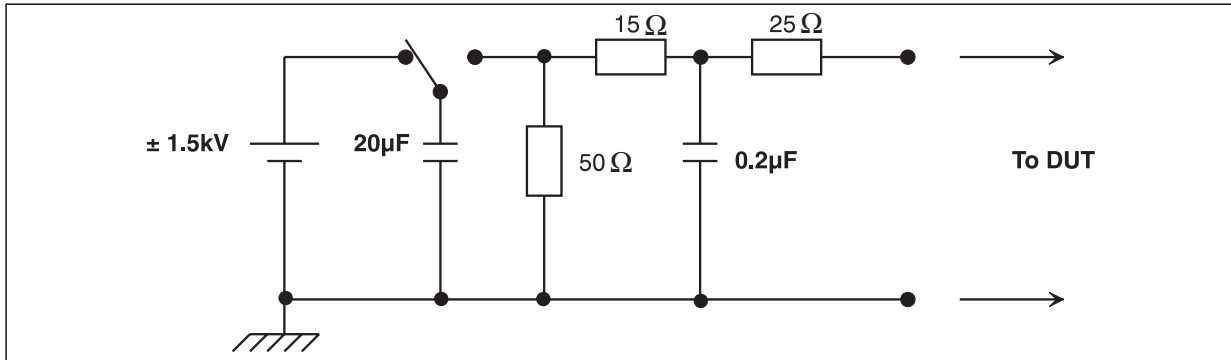

The behaviour of the TSI200B1 to this lightning surge is given below (fig. 3).

Fig. 3 : Voltage across the TSI200B1 at the + and - terminations and current through it for a 1.5 kV positive surge (fig.3a) and negative surge (fig. 3b)

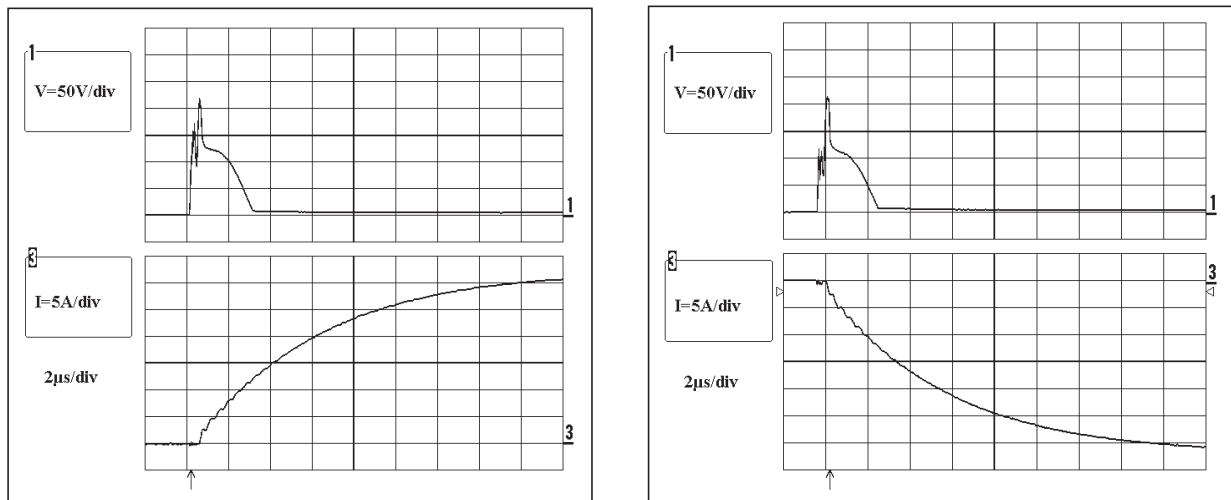

These curves show the peak voltage the surge generates across the TSI200B1 + and - terminations. This lasts a short time ($\sim 2 \mu\text{s}$) and after, as the internal protection behaves like a short circuit. The voltage drop across the TSIxxB1 becomes a few volts. In the meanwhile all the surge current flows in the protection.

As far as the 10/700 μs waveform surge test is concerned, the TSIxxB1 withstand the $\pm 1.5 \text{ kV}$ test.

**TEST # 2
AC POWER INDUCTION TEST**

This test simulates the induction phenomena that can happen between telecom lines and AC mains lines (fig. 4).

Fig. 4 : AC power induction test circuit

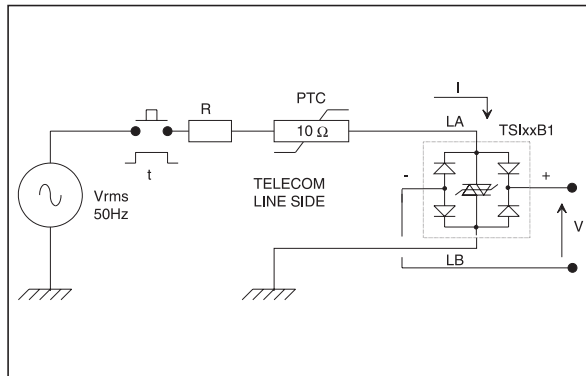

- Part #1
test conditions : $V_{RMS} = 240\text{ V}$
 $R = 600\ \Omega$
 $t = 0.2\text{ s}$
- Part #2
test conditions : $V_{RMS} = 600\text{ V}$
 $R = 600\ \Omega$
 $t = 0.2\text{ s}$

Fig. 5 : Voltage at the + and - terminations of the TSI200B1, and current through it while test part 1 is applied.

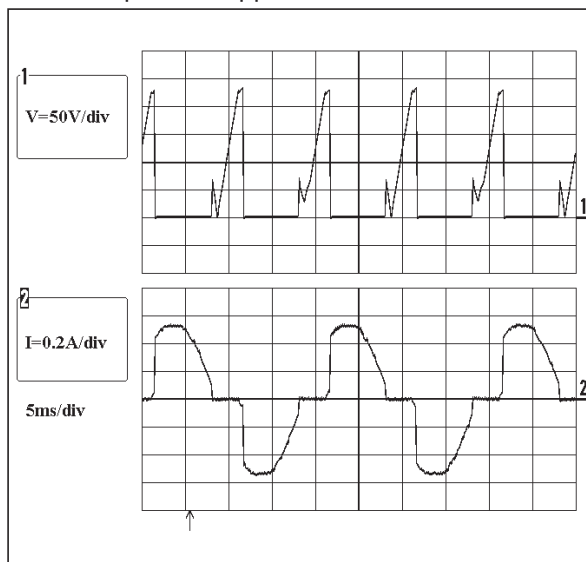

The TSIxxB1 withstand the AC power induction test in both cases.

**TEST #3
AC POWER CONTACT TEST**

This test simulates the direct contact between the telecom lines and the AC mains lines.

The AC power contact test consists in applying $240V_{RMS}$ through a $10\ \Omega$ PTC during 15 minutes long on the device under test. The CCITT K17 recommendation specifies an internal generator impedance allowing $10\ A_{RMS}$ when in short circuit.

The behavior of the TSI200B1 with respect to this surge is given in figure 6.

Fig. 6 : Voltage at the TSI200B1 + & - terminations and the current through it.

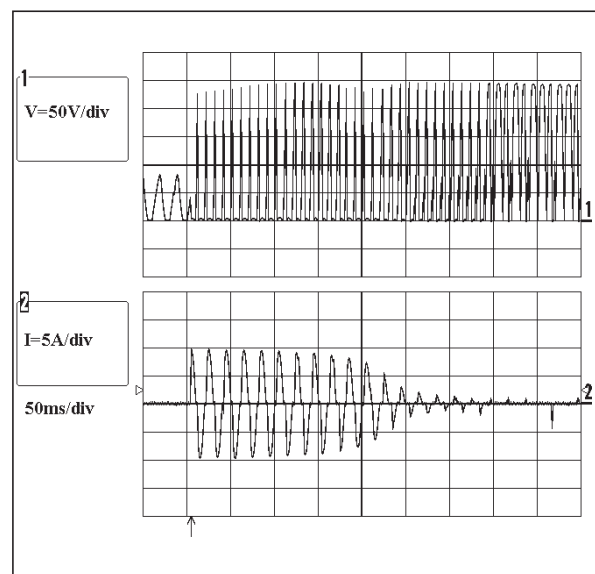

The figure 6 shows that after 250ms there is no current anymore flowing through the TSI200B1 device. This is due to the action of the serial PTC that limits the current through the line. This PTC is mandatory for this test. It can also be replaced by a fuse or any other serial protection that “opens” the line loop under AC contact test.

TS1xxB1

ABSOLUTE MAXIMUM RATINGS (T_{amb} = 25°C)

Symbol	Parameter	Value	Unit
I _{PP}	Non repetitive peak on-state current (see note 1)		
	10/1000 μs (open circuit voltage wave shape 10/100 μs)	30	A
	5/310 μs (open circuit voltage wave shape 10/700 μs)	40	
	2/10 μs (open circuit voltage wave shape 2/10 μs)	75	
I _F	Maximum DC current	0.2	A
I _{TSM}	Non repetitive surge peak on-state current	t _p = 20 ms	5
		t = 1 s	3.5
T _{stg}	Storage temperature range	- 55 to +150	°C
T _j	Maximum junction temperature	150	
T _L	Maximum lead temperature for soldering during 10 s	260	°C

Note 1 : Pulse waveform :

10/1000μs	t _r =10μs	t _p =1000μs
5/310μs	t _r =5μs	t _p =310μs
2/10μs	t _r =2μs	t _p =10μs

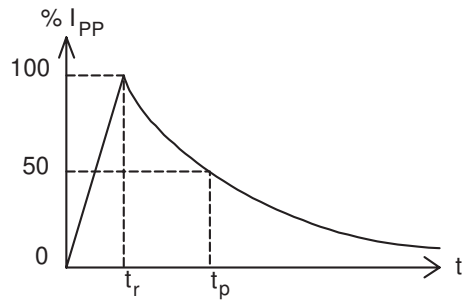

THERMAL RESISTANCE

Symbol	Parameter	Value	Unit
R _{th(j-a)}	Junction to ambient	170	°C/W

ELECTRICAL CHARACTERISTICS (T_{amb}=25°C)

Symbol	Parameter
V _{RM}	Stand-off voltage
V _{BO}	Breakover voltage
V _{BR}	Breakdown voltage
I _H	Holding current
I _{BO}	Breakover current
I _{RM}	Leakage current at V _{RM}
I _{PP}	Peak pulse current
C	Capacitance
αT	Temperature coefficient

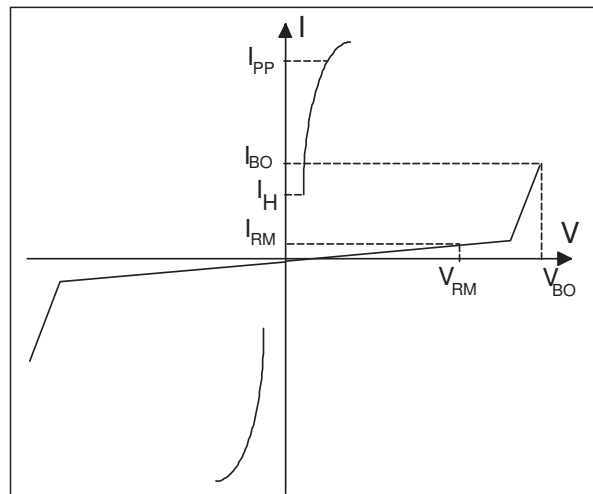

ELECTRICAL CHARACTERISTICS ($T_{amb} = 25\text{ }^{\circ}\text{C}$)
1 - PROTECTION DEVICES PARAMETERS

Type	$I_{RM} @ V_{RM}$		$V_{BO} @ I_{BO}$ note1 V max.	I_H note2 mA min.	I_{BO} note1 mA		C note3 pF typ.
	μA max.	V			min.	max.	
TSI62B1	1 5	50 62	90	150	50	400	200
TSI180B1	1 5	50 180	250	150	50	400	200
TSI200B1	1 5	50 200	290	150	50	400	200
TSI220B1	1 5	50 220	330	150	50	400	200
TSI265B1	1 5	50 265	380	150	50	400	200

Note 1 : Measured at 50 Hz, one cycle

Note 2 : See test circuit

Note 3 : $V_R = 0\text{V}$, $F = 1\text{MHz}$, between pins 1 and 8.

2 - DIODE BRIDGE PARAMETERS

Symbol	Test condition	Value	Unit
V_F (for one diode)	$I_F = 20\text{ mA}$	0.9	V
	$I_F = 100\text{ mA}$	1.1	V

FUNCTIONAL HOLDING CURRENT (I_H) TEST CIRCUIT : GO - NO GO TEST

This is a GO-NOGO Test which allows to confirm the holding current (I_H) level in a functional test circuit.

TEST PROCEDURE :

- 1) Adjust the current level at the I_H value by short circuiting the D.U.T.
- 2) Fire the D.U.T with a surge Current : $I_{pp} = 10\text{A}$, $10/1000\text{ }\mu\text{s}$.
- 3) The D.U.T will come back off-state within a duration of 50 ms max.

TSIxxB1

MARKING

Type	Marking
TSI180B1	TSI180
TSI200B1	TSI200
TSI220B1	TSI220

ORDER CODE

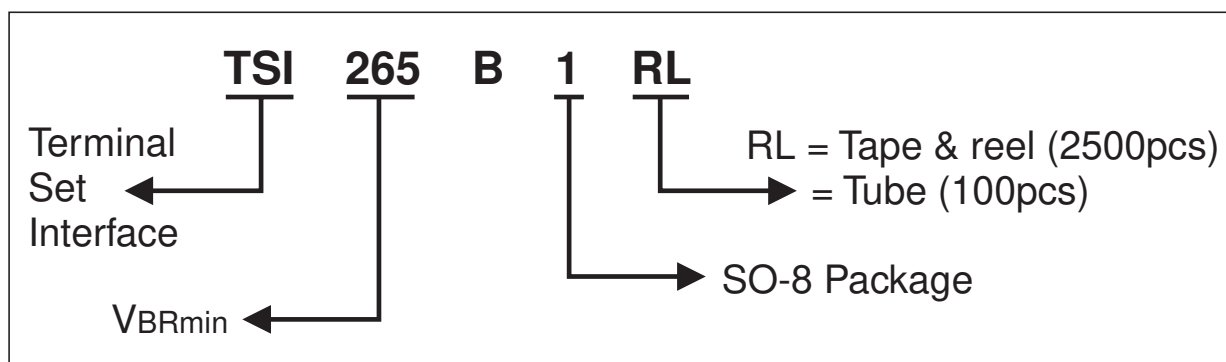

PACKAGE MECHANICAL DATA
SO-8

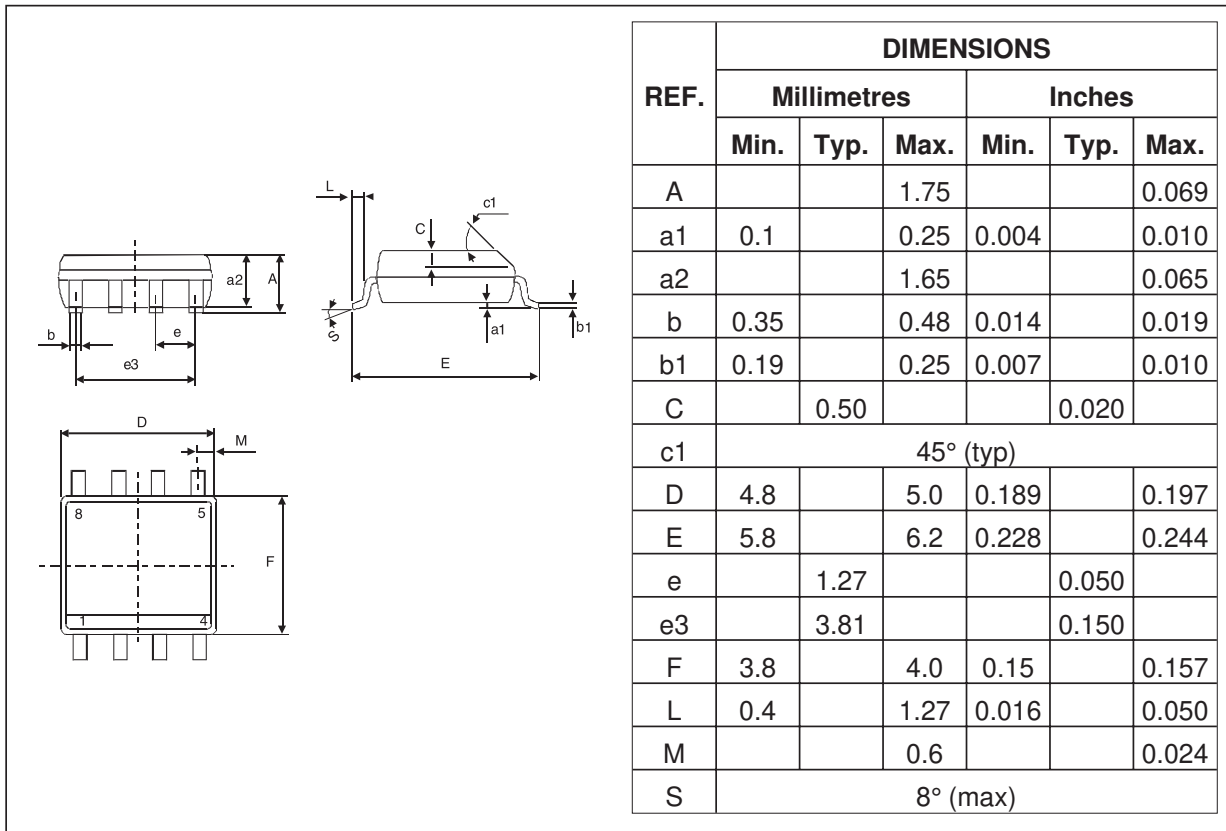

Packaging : product supplied in tape and reel or antistatic tubes.

Information furnished is believed to be accurate and reliable. However, STMicroelectronics assumes no responsibility for the consequences of use of such information nor for any infringement of patents or other rights of third parties which may result from its use. No license is granted by implication or otherwise under any patent or patent rights of STMicroelectronics. Specifications mentioned in this publication are subject to change without notice. This publication supersedes and replaces all information previously supplied. STMicroelectronics products are not authorized for use as critical components in life support devices or systems without express written approval of STMicroelectronics.

The ST logo is a registered trademark of STMicroelectronics.

All other names are the property of their respective owners.

© 2003 STMicroelectronics - All rights reserved.

STMicroelectronics GROUP OF COMPANIES

Australia - Belgium - Brazil - Canada - China - Czech Republic - Finland - France - Germany - Hong Kong - India - Israel - Italy - Japan - Malaysia - Malta - Morocco - Singapore - Spain - Sweden - Switzerland - United Kingdom - United States

www.st.com

