



Chipsmall Limited consists of a professional team with an average of over 10 year of expertise in the distribution of electronic components. Based in Hongkong, we have already established firm and mutual-benefit business relationships with customers from,Europe,America and south Asia,supplying obsolete and hard-to-find components to meet their specific needs.

With the principle of “Quality Parts,Customers Priority,Honest Operation,and Considerate Service”,our business mainly focus on the distribution of electronic components. Line cards we deal with include Microchip,ALPS,ROHM,Xilinx,Pulse,ON,Everlight and Freescale. Main products comprise IC,Modules,Potentiometer,IC Socket,Relay,Connector.Our parts cover such applications as commercial,industrial, and automotives areas.

We are looking forward to setting up business relationship with you and hope to provide you with the best service and solution. Let us make a better world for our industry!



Contact us

Tel: +86-755-8981 8866 Fax: +86-755-8427 6832

Email & Skype: info@chipsmall.com Web: www.chipsmall.com

Address: A1208, Overseas Decoration Building, #122 Zhenhua RD., Futian, Shenzhen, China



- High-Resolution Conversion of Light Intensity to Frequency With No External Components
- Communicates Directly With a Microcontroller
- Compact Three-Leaded Plastic Package
- Integral Visible-Light Cutoff Filter
- Single-Supply Operation . . . 2.7 V to 5.5 V
- High Irradiance Responsivity . . . Typically 500 Hz/($\mu\text{W}/\text{cm}^2$) at 940 nm
- Nonlinearity Error Typically 0.2% at 100 kHz
- Available in Through-Hole and Surface Mount Three-Lead Sidelooker Packages
- Replacement for TSL245
- Lead (Pb) Free Package Option Available

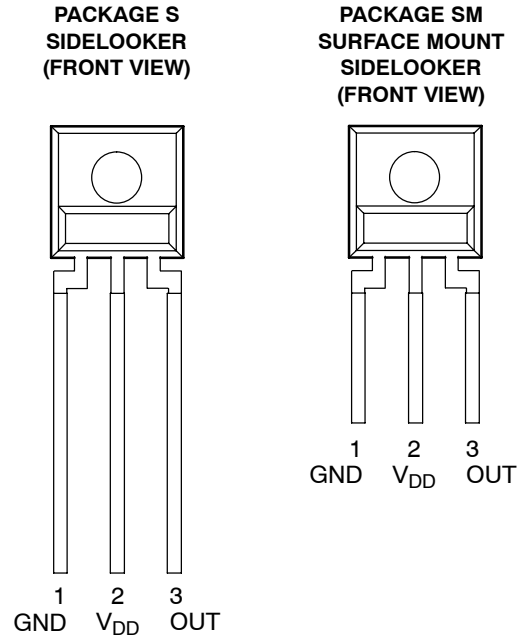

Description

The TSL245R light-to-frequency converter combines a silicon photodiode and a current-to-frequency converter on a single monolithic CMOS integrated circuit. Output is a square wave (50% duty cycle) with frequency directly proportional to light intensity (irradiance) on the photodiode. The digital output allows direct interface to a microcontroller or other logic circuitry. The TSL245R is characterized for operation over the temperature range of -25°C to 70°C and is supplied in a 3-lead plastic side-looker package with an integral visible-light cutoff filter and lens. When supplied in the lead (Pb) free package, the devices are RoHS compliant.

Functional Block Diagram



Available Options

DEVICE	T _A	PACKAGE - LEADS	PACKAGE DESIGNATOR	ORDERING NUMBER
TSL245R	-25°C to 70°	3-lead Sidelooker	S	TSL245R
TSL245R	-25°C to 70°	3-lead Sidelooker — Lead (Pb) Free	S	TSL245R-LF
TSL245R	-25°C to 70°	3-lead Surface Mount Sidelooker	SM	TSL245RSM
TSL245R	-25°C to 70°	3-lead Surface Mount Side-Looker — Lead (Pb) Free	SM	TSL245RSM-LF

TSL245R INFRARED LIGHT-TO-FREQUENCY CONVERTER

TAOS060D – SEPTEMBER 2007

Terminal Functions

TERMINAL NAME	NO.	TYPE	DESCRIPTION
GND	1		Power supply ground (substrate). All voltages are referenced to GND.
OUT	3	O	Output voltage.
V _{DD}	2		Supply voltage.

Absolute Maximum Ratings over operating free-air temperature range (unless otherwise noted)[†]

Supply voltage, V _{DD} (see Note 1)	6 V
Operating free-air temperature range, T _A	-25°C to 70°C
Storage temperature range, T _{stg}	-25°C to 85°C
Lead temperature 1,6 mm (1/16 inch) from case for 10 seconds (S Package)	260°C
Reflow solder, in accordance with J-STD-020C or J-STD-020D (SM Package)	260°C

[†] Stresses beyond those listed under “absolute maximum ratings” may cause permanent damage to the device. These are stress ratings only, and functional operation of the device at these or any other conditions beyond those indicated under “recommended operating conditions” is not implied. Exposure to absolute-maximum-rated conditions for extended periods may affect device reliability.

NOTE 1: All voltage values are with respect to GND.

Recommended Operating Conditions

	MIN	NOM	MAX	UNIT
Supply voltage, V _{DD}	2.7	5	5.5	V
Operating free-air temperature range, T _A	-25		70	°C

Electrical Characteristics at V_{DD} = 5 V, T_A = 25°C (unless otherwise noted)

PARAMETER	TEST CONDITIONS	MIN	TYP	MAX	UNIT
V _{OH} High-level output voltage	I _{OH} = -4 mA	4	4.5		V
V _{OL} Low-level output voltage	I _{OL} = 4 mA		0.25	0.4	V
I _{DD} Supply current			2	3	mA
Full-scale frequency [‡]		500			kHz
k _{SVS} Supply-voltage sensitivity	V _{DD} = 5 V ±10%		±0.5		%/V

[‡] Full-scale frequency is the maximum operating frequency of the device without saturation.

Operating Characteristics at V_{DD} = 5 V, T_A = 25°C, λ_p = 940 nm

PARAMETER	TEST CONDITIONS	MIN	TYP	MAX	UNIT
f _O Output frequency	E _e = 40 μW/cm ²	10	20	30	kHz
f _D Dark frequency	E _e = 0 μW/cm ²		0.4	10	Hz
R _e Irradiance responsivity			0.5		kHz/(μW/cm ²)
Nonlinearity [§]	f _O = 0 kHz to 10 kHz		±0.1%		%F.S.
	f _O = 0 kHz to 100 kHz		±0.2%		%F.S.
Step response to full-scale step input			1 pulse of new frequency plus 1 μs		

[§] Nonlinearity is defined as the deviation of f_O from a straight line between zero and full scale, expressed as a percent of full scale.

TYPICAL CHARACTERISTICS

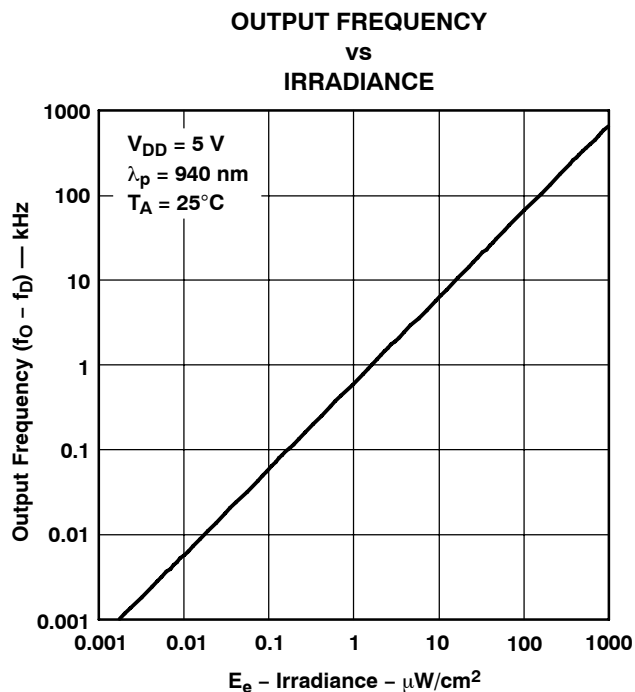

Figure 1

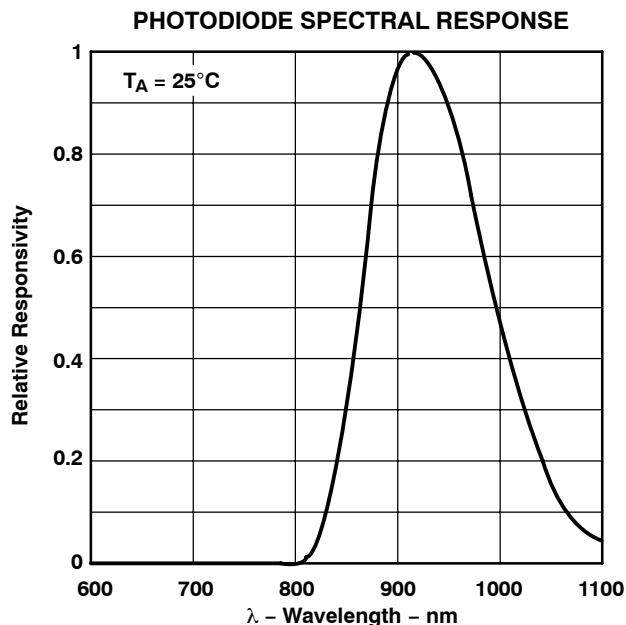

Figure 2

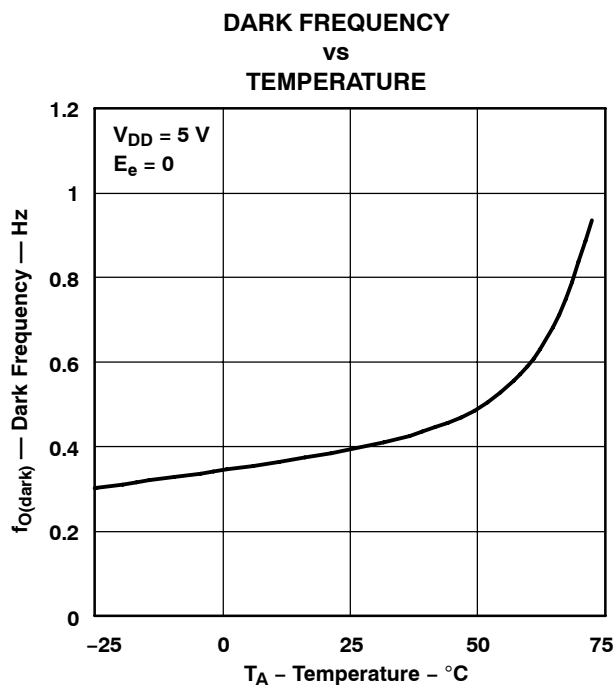

Figure 3

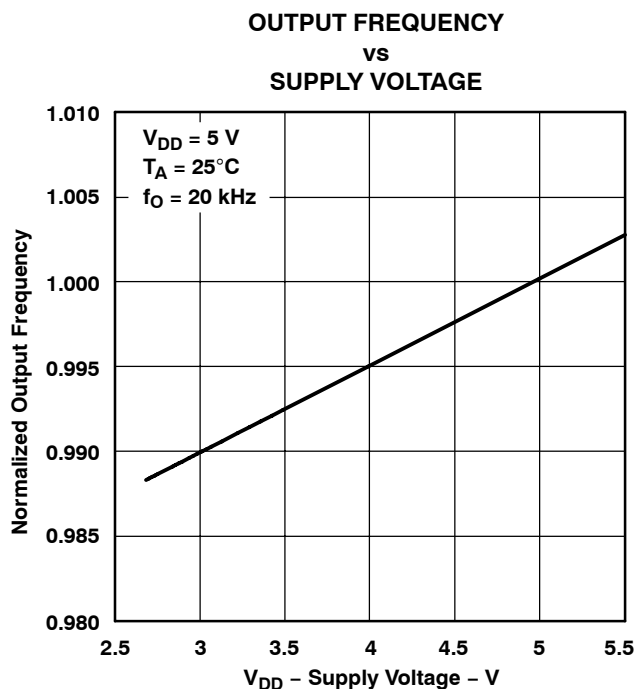

Figure 4

TSL245R INFRARED LIGHT-TO-FREQUENCY CONVERTER

TAOS060D – SEPTEMBER 2007

APPLICATION INFORMATION

Power-supply considerations

Power-supply lines must be decoupled by a 0.01- μF to 0.1- μF capacitor with short leads placed close to the TSL245R (Figure 5). A low-noise power supply is required to minimize jitter on output pulse.

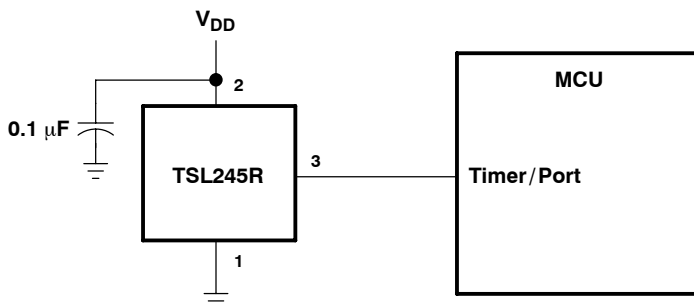

Figure 5. Typical TSL245R Interface to a Microcontroller

Device Operational Details

The frequency at the output pin (OUT) is given by:

$$f_O = f_D + (R_e) (E_e)$$

where:

- f_O is the output frequency
- f_D is the output frequency for dark condition ($E_e = 0$)
- R_e is the device responsivity for a given wavelength of light given in $\text{kHz}/(\mu\text{W}/\text{cm}^2)$
- E_e is the incident irradiance in $\mu\text{W}/\text{cm}^2$

f_D is an output frequency resulting from leakage currents. As shown in the equation above, this frequency represents a light-independent term in the total output frequency f_O . At very low light levels, this dark frequency can be a significant portion of f_O . The dark frequency is temperature dependent. For optimum performance of any given device over the full output range, the value of f_D should be measured (in the absence of light) and later subtracted from subsequent light measurement (see Figure 1).

Output interface

The output of the device is designed to drive a standard TTL or CMOS logic input over short distances. If lines greater than 12 inches are used on the output, a buffer or line driver is recommended.

Measuring the frequency

The choice of interface and measurement technique depends on the desired resolution and data-acquisition rate. For maximum data-acquisition rate, period-measurement techniques are used.

Period measurement requires the use of a fast reference clock with available resolution directly related to reference-clock rate. The technique is employed to measure rapidly varying light levels or to make a fast measurement of a constant light source.

Maximum resolution and accuracy may be obtained using frequency-measurement, pulse-accumulation, or integration techniques. Frequency measurements provide the added benefit of averaging out random- or high-frequency variations (jitter) resulting from noise in the light signal. Resolution is limited mainly by available counter registers and allowable measurement time. Frequency measurement is well suited for slowly varying or constant light levels and for reading average light levels over short periods of time. Integration, the accumulation of pulses over a very long period of time, can be used to measure exposure — the amount of light present in an area over a given time period.

APPLICATION INFORMATION

PCB Pad Layout

Suggested PCB pad layout guidelines for the SM surface mount package are shown in Figure 6.

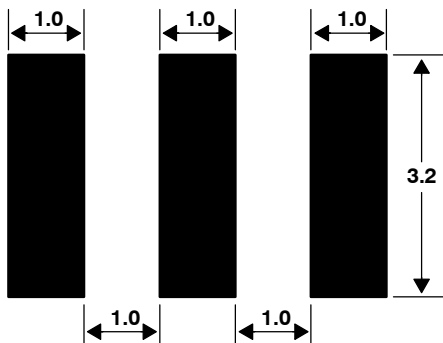

- NOTES: A. All linear dimensions are in millimeters.
B. This drawing is subject to change without notice.

Figure 6. Suggested SM Package PCB Layout

TSL245R INFRARED LIGHT-TO-FREQUENCY CONVERTER

TAOS060D – SEPTEMBER 2007

MECHANICAL DATA

PACKAGE S

PLASTIC SINGLE-IN-LINE SIDE-LOOKER PACKAGE

TOP VIEW

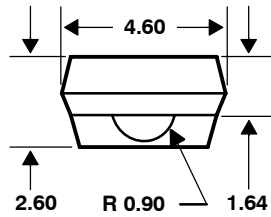

FRONT VIEW

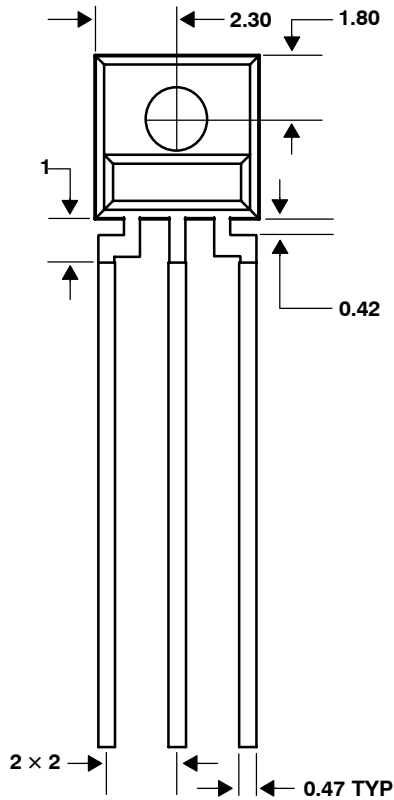

SIDE VIEW

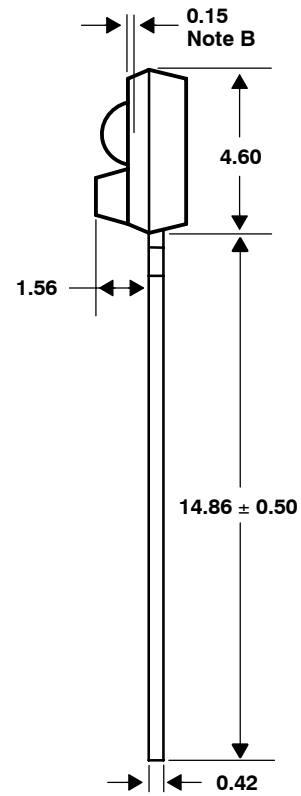

Lead Free
Available

- NOTES: A. All linear dimensions are in millimeters; tolerance is ± 0.25 mm unless otherwise stated.
 B. Dimension is to center of lens arc, which is located below the package face.
 C. The $0.96 \text{ mm} \times 0.96 \text{ mm}$ integrated photodiode active area is typically located in the center of the lens and 0.97 mm below the top of the lens surface.
 D. Lead finish for TSL245R: solder dipped, 63% Sn/37% Pb. Lead finish for TSL245xR-LF: solder dipped, 100% Sn.
 E. This drawing is subject to change without notice.

Figure 7. Package S — Single-In-Line Side-Looker Package Configuration

MECHANICAL DATA

PACKAGE SM

PLASTIC SURFACE MOUNT SIDE-LOOKER PACKAGE

TOP VIEW

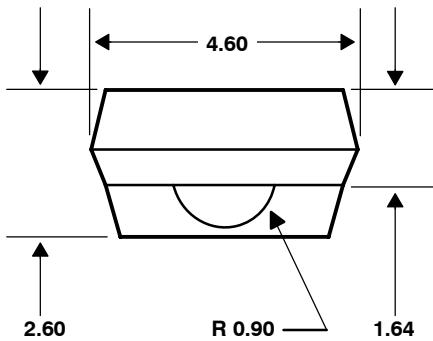

FRONT VIEW

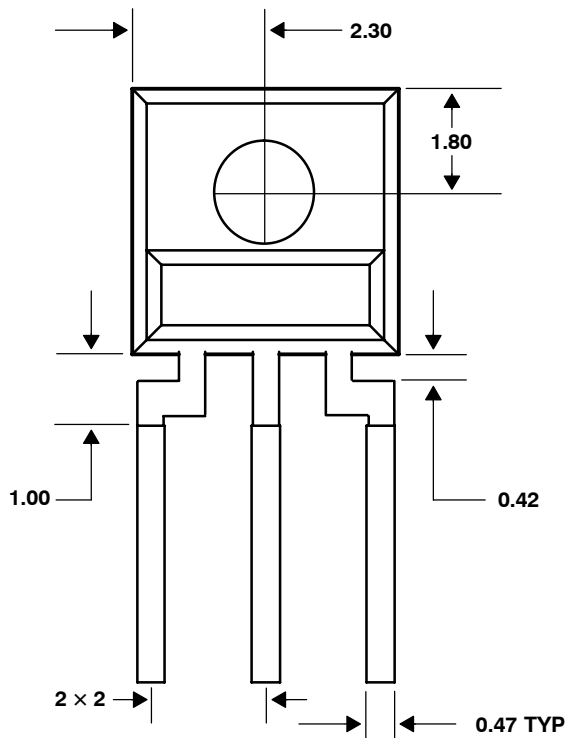

SIDE VIEW

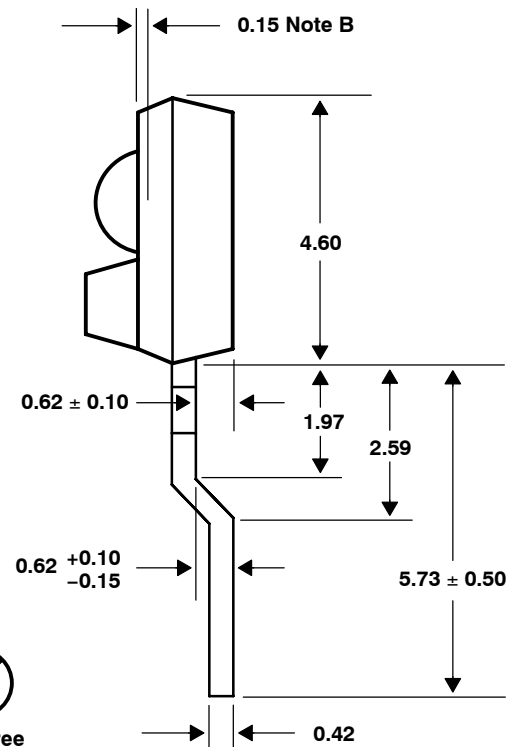

- NOTES: A. All linear dimensions are in millimeters; tolerance is ± 0.25 mm unless otherwise stated.
 B. Dimension is to center of lens arc, which is located below the package face.
 C. The $0.96 \text{ mm} \times 0.96 \text{ mm}$ integrated photodiode active area is typically located in the center of the lens and 0.97 mm below the top of the lens surface.
 D. Lead finish for TSL245RSM: solder dipped, 63% Sn/37% Pb. Lead finish for TSL245xRSM-LF: solder dipped, 100% Sn.
 E. This drawing is subject to change without notice.

Figure 8. Package SM — Surface Mount Side-Looker Package Configuration

TSL245R INFRARED LIGHT-TO-FREQUENCY CONVERTER

TAOS060D – SEPTEMBER 2007

MECHANICAL DATA

TOP VIEW

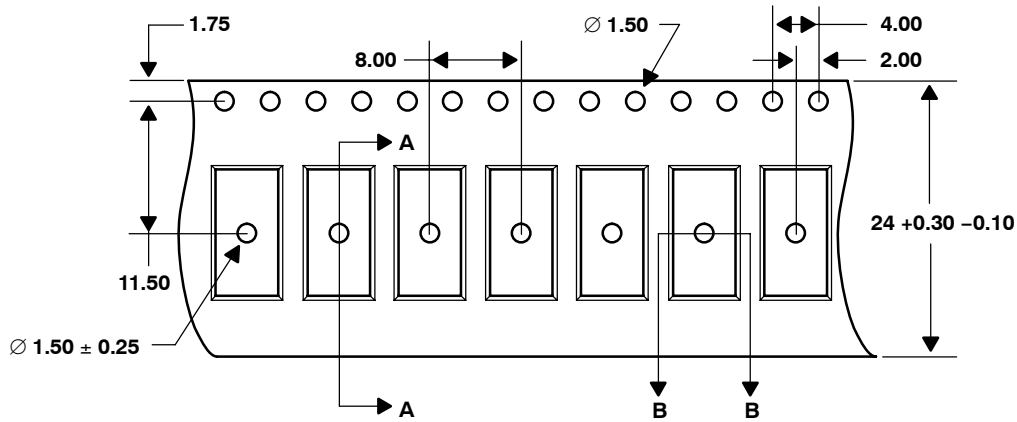

DETAIL A

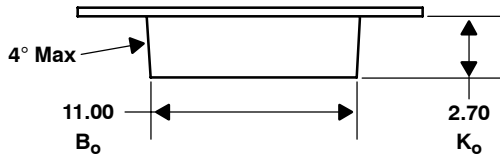

DETAIL B

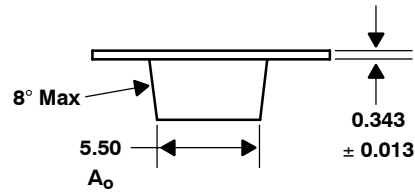

- NOTES: A. All linear dimensions are in millimeters, dimension tolerance is ± 0.10 mm unless otherwise noted.
 B. The dimensions on this drawing are for illustrative purposes only. Dimensions of an actual carrier may vary slightly.
 C. Symbols on drawing A_o , B_o , and K_o are defined in ANSI EIA Standard 481-B 2001.
 D. Each reel is 33 millimeters in diameter and contains 2500 parts.
 E. TAOS packaging tape and reel conform to the requirements of EIA Standard 481-B.
 F. Only surface mount parts (package SM) are supplied in tape and reel.
 G. This drawing is subject to change without notice.

Figure 9. Package SM Carrier Tape

PRODUCTION DATA — information in this document is current at publication date. Products conform to specifications in accordance with the terms of Texas Advanced Optoelectronic Solutions, Inc. standard warranty. Production processing does not necessarily include testing of all parameters.

LEAD-FREE (Pb-FREE) and GREEN STATEMENT

Pb-Free (RoHS) TAOS' terms *Lead-Free* or *Pb-Free* mean semiconductor products that are compatible with the current RoHS requirements for all 6 substances, including the requirement that lead not exceed 0.1% by weight in homogeneous materials. Where designed to be soldered at high temperatures, TAOS Pb-Free products are suitable for use in specified lead-free processes.

Green (RoHS & no Sb/Br) TAOS defines *Green* to mean Pb-Free (RoHS compatible), and free of Bromine (Br) and Antimony (Sb) based flame retardants (Br or Sb do not exceed 0.1% by weight in homogeneous material).

Important Information and Disclaimer The information provided in this statement represents TAOS' knowledge and belief as of the date that it is provided. TAOS bases its knowledge and belief on information provided by third parties, and makes no representation or warranty as to the accuracy of such information. Efforts are underway to better integrate information from third parties. TAOS has taken and continues to take reasonable steps to provide representative and accurate information but may not have conducted destructive testing or chemical analysis on incoming materials and chemicals. TAOS and TAOS suppliers consider certain information to be proprietary, and thus CAS numbers and other limited information may not be available for release.

NOTICE

Texas Advanced Optoelectronic Solutions, Inc. (TAOS) reserves the right to make changes to the products contained in this document to improve performance or for any other purpose, or to discontinue them without notice. Customers are advised to contact TAOS to obtain the latest product information before placing orders or designing TAOS products into systems.

TAOS assumes no responsibility for the use of any products or circuits described in this document or customer product design, conveys no license, either expressed or implied, under any patent or other right, and makes no representation that the circuits are free of patent infringement. TAOS further makes no claim as to the suitability of its products for any particular purpose, nor does TAOS assume any liability arising out of the use of any product or circuit, and specifically disclaims any and all liability, including without limitation consequential or incidental damages.

TEXAS ADVANCED OPTOELECTRONIC SOLUTIONS, INC. PRODUCTS ARE NOT DESIGNED OR INTENDED FOR USE IN CRITICAL APPLICATIONS IN WHICH THE FAILURE OR MALFUNCTION OF THE TAOS PRODUCT MAY RESULT IN PERSONAL INJURY OR DEATH. USE OF TAOS PRODUCTS IN LIFE SUPPORT SYSTEMS IS EXPRESSLY UNAUTHORIZED AND ANY SUCH USE BY A CUSTOMER IS COMPLETELY AT THE CUSTOMER'S RISK.

LUMENOLOGY, TAOS, the TAOS logo, and Texas Advanced Optoelectronic Solutions are registered trademarks of Texas Advanced Optoelectronic Solutions Incorporated.

TSL245R INFRARED LIGHT-TO-FREQUENCY CONVERTER

TAOS060D – SEPTEMBER 2007
