



Chipsmall Limited consists of a professional team with an average of over 10 year of expertise in the distribution of electronic components. Based in Hongkong, we have already established firm and mutual-benefit business relationships with customers from,Europe,America and south Asia,supplying obsolete and hard-to-find components to meet their specific needs.

With the principle of “Quality Parts,Customers Priority,Honest Operation,and Considerate Service”,our business mainly focus on the distribution of electronic components. Line cards we deal with include Microchip,ALPS,ROHM,Xilinx,Pulse,ON,Everlight and Freescale. Main products comprise IC,Modules,Potentiometer,IC Socket,Relay,Connector.Our parts cover such applications as commercial,industrial, and automotives areas.

We are looking forward to setting up business relationship with you and hope to provide you with the best service and solution. Let us make a better world for our industry!



## Contact us

Tel: +86-755-8981 8866 Fax: +86-755-8427 6832

Email & Skype: info@chipsmall.com Web: www.chipsmall.com

Address: A1208, Overseas Decoration Building, #122 Zhenhua RD., Futian, Shenzhen, China





**TAOS Inc.**

**is now**

**ams AG**

The technical content of this TAOS datasheet is still valid.

**Contact information:**

**Headquarters:**

ams AG

Tobelbaderstrasse 30

8141 Unterpremstaetten, Austria

Tel: +43 (0) 3136 500 0

e-Mail: [ams\\_sales@ams.com](mailto:ams_sales@ams.com)

Please visit our website at [www.ams.com](http://www.ams.com)

- Converts Light Intensity to Output Voltage
- Monolithic Silicon IC Containing Photodiode, Operational Amplifier, and Feedback Components
- High Sensitivity
- Single Voltage Supply Operation (2.7 V to 5.5 V)
- High Irradiance Responsivity . . . Typical 680 mV/( $\mu\text{W}/\text{cm}^2$ ) at  $\lambda_p = 640 \text{ nm}$
- Low Noise (200  $\mu\text{V}_{\text{rms}}$  Typ to 1 kHz)
- Rail-to-Rail Output
- High Power-Supply Rejection (35 dB at 1 kHz)
- Low-Profile Surface-Mount Package
- RoHS Compliant

PACKAGE T  
4-LEAD SMD  
(TOP VIEW)

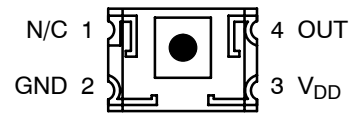

### Description

The TSL257T is a high-sensitivity low-noise light-to-voltage optical converter that combines a photodiode and a transimpedance amplifier on a single monolithic CMOS integrated circuit. Output voltage is directly proportional to light intensity (irradiance) on the photodiode. The TSL257T has a transimpedance gain of 320 M $\Omega$ . The device has improved offset voltage stability and low power consumption and is supplied in a compact 4-lead surface-mount package.

### Functional Block Diagram

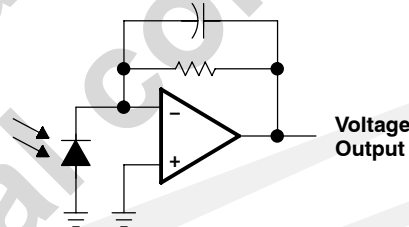

### Terminal Functions

TERMINAL NAME	T PKG NO.	DESCRIPTION
GND	2	Power supply ground (substrate). All voltages are referenced to GND.
OUT	4	Output voltage.
V <sub>DD</sub>	3	Supply voltage.
N/C	1	No connection.

# TSL257T HIGH-SENSITIVITY LIGHT-TO-VOLTAGE CONVERTER

TAOS065B – APRIL 2007

## Absolute Maximum Ratings over operating free-air temperature range (unless otherwise noted)<sup>†</sup>

Supply voltage, $V_{DD}$ (see Note 1)	6 V
Output current, $I_O$	$\pm 10$ mA
Duration of short-circuit current at (or below) 25°C	5 s
Operating free-air temperature range, $T_A$	-25°C to 85°C
Storage temperature range, $T_{stg}$	-25°C to 85°C
Solder conditions in accordance with JEDEC–J–SRD–020A, maximum temperature	260°C

<sup>†</sup> Stresses beyond those listed under “absolute maximum ratings” may cause permanent damage to the device. These are stress ratings only, and functional operation of the device at these or any other conditions beyond those indicated under “recommended operating conditions” is not implied. Exposure to absolute-maximum-rated conditions for extended periods may affect device reliability.

NOTE 1: All voltages are with respect to GND.

## Recommended Operating Conditions

	MIN	MAX	UNIT
Supply voltage, $V_{DD}$	2.7	5.5	V
Operating free-air temperature, $T_A$	0	70	°C

## Electrical Characteristics at $V_{DD} = 5$ V, $T_A = 25^\circ\text{C}$ , $\lambda_p = 640$ nm, $R_L = 10$ k $\Omega$ (unless otherwise noted) (see Notes 2, 3, and 4)

PARAMETER	TEST CONDITIONS	MIN	TYP	MAX	UNIT
$V_D$ Dark voltage	$E_e = 0$	0		15	mV
$V_{OM}$ Maximum output voltage swing	$V_{DD} = 4.5$ V, No Load		4.49		V
	$V_{DD} = 4.5$ V, $R_L = 10$ k $\Omega$	4	4.2		
$V_O$ Output voltage	$E_e = 2.93$ $\mu\text{W}/\text{cm}^2$	1.5	2	2.5	V
$\alpha_{VD}$ Temperature coefficient of dark voltage ( $V_D$ )	$T_A = 0^\circ\text{C}$ to 70°C		-15		$\mu\text{V}/^\circ\text{C}$
$R_e$ Irradiance responsivity	See Note 5		680		$\text{mV}/(\mu\text{W}/\text{cm}^2)$
PSRR Power supply rejection ratio	$f_{ac} = 100$ Hz, see Note 6		55		dB
	$f_{ac} = 1$ kHz, see Note 6		35		
$I_{DD}$ Supply current	$E_e = 2.93$ $\mu\text{W}/\text{cm}^2$		2	3.8	mA

NOTES: 2. Measured with  $R_L = 10$  k $\Omega$  between output and ground.

3. Optical measurements are made using small-angle incident radiation from a light-emitting diode (LED) optical source.

4. The input irradiance  $E_e$  is supplied by an AlInGaP LED with peak wavelength  $\lambda_p = 640$  nm.

5. Irradiance responsivity is characterized over the range  $V_O = 0.1$  V to 4.5 V. The best-fit straight line of Output Voltage  $V_O$  versus Irradiance  $E_e$  over this range will typically have a positive extrapolated  $V_O$  value for  $E_e = 0$ .

6. Power supply rejection ratio PSRR is defined as  $20 \log (\Delta V_{DD}(f)/\Delta V_O(f))$  with  $V_{DD}(f = 0) = 5$  V and  $V_O(f = 0) = 2$  V.

## Switching Characteristics at $V_{DD} = 5$ V, $T_A = 25^\circ\text{C}$ , $\lambda_p = 640$ nm, $R_L = 10$ k $\Omega$ (unless otherwise noted)

PARAMETER	TEST CONDITIONS	MIN	TYP	MAX	UNIT
$t_r$ Output pulse rise time, 10% to 90% of final value	See Note 10 and Figure 1		160	250	$\mu\text{s}$
$t_f$ Output pulse fall time, 10% to 90% of final value	See Note 10 and Figure 1		150	250	$\mu\text{s}$
$t_s$ Output settling time to 1% of final value	See Note 10 and Figure 1		330		$\mu\text{s}$
Integrated noise voltage	$f = \text{dc}$ to 1 kHz $E_e = 0$		200		$\mu\text{V}_{\text{rms}}$
$V_n$ Output noise voltage, rms	$f = 10$ Hz $E_e = 0$		6		$\mu\text{V}/\sqrt{\text{Hz}}$ rms
	$f = 100$ Hz $E_e = 0$		6		
	$f = 1$ kHz $E_e = 0$		7		

NOTE 7: Switching characteristics apply over the range  $V_O = 0.1$  V to 4.5 V.

**PARAMETER MEASUREMENT INFORMATION**

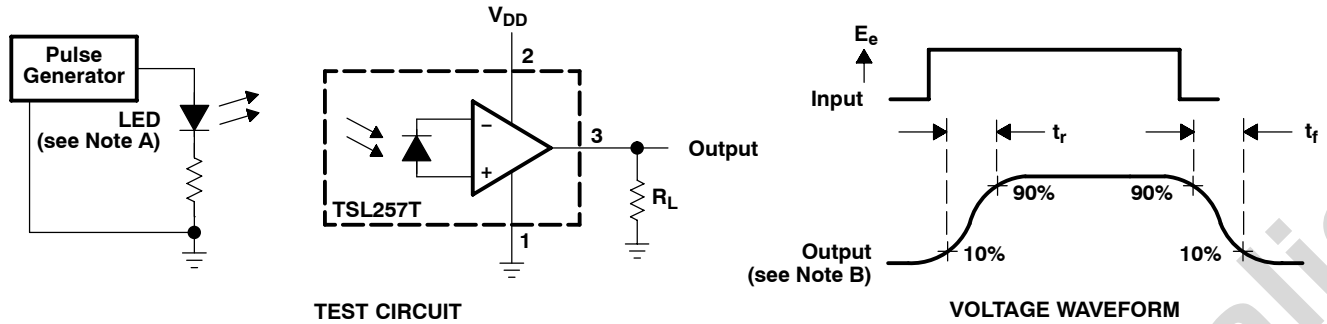

NOTES: A. The input irradiance is supplied by a pulsed AlInGaP light-emitting diode with the following characteristics:  $\lambda_p = 640 \text{ nm}$ ,  $t_r < 1 \mu\text{s}$ ,  $t_f < 1 \mu\text{s}$ .  
 B. The output waveform is monitored on an oscilloscope with the following characteristics:  $t_r < 100 \text{ ns}$ ,  $Z_i \geq 1 \text{ M}\Omega$ ,  $C_i \leq 20 \text{ pF}$ .

**Figure 1. Switching Times**

**TYPICAL CHARACTERISTICS**

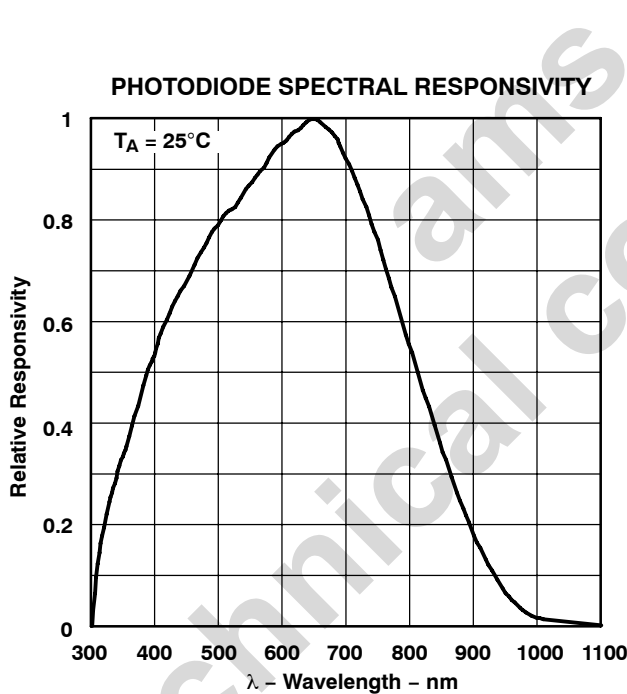

**Figure 2**

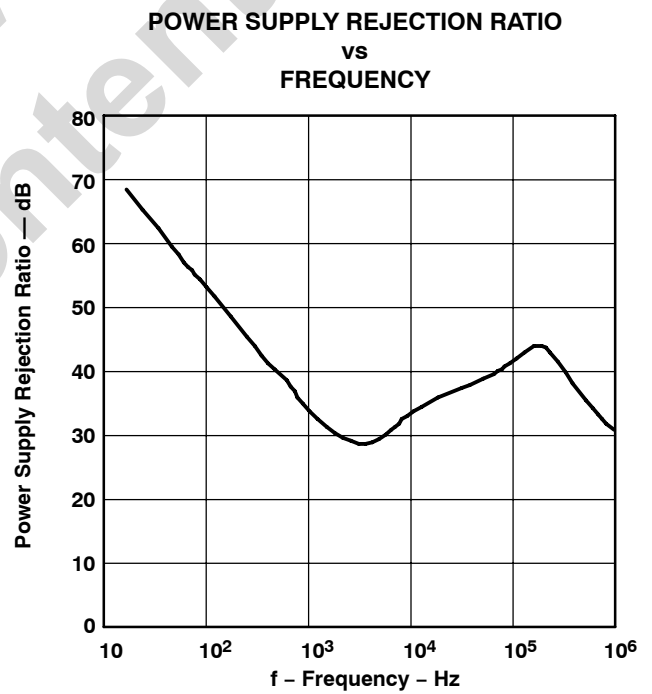

**Figure 3**

**TYPICAL CHARACTERISTICS**

**DARK VOLTAGE**  
**vs**  
**FREE-AIR TEMPERATURE**

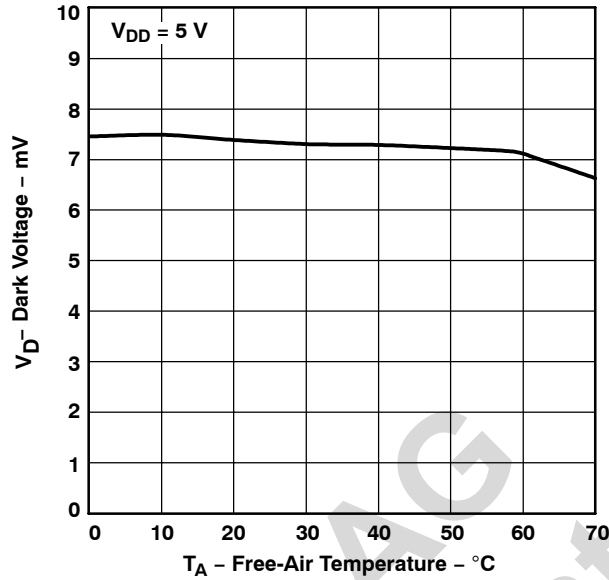

**Figure 4**

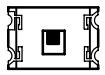

**NORMALIZED OUTPUT VOLTAGE**  
**vs.**  
**ANGULAR DISPLACEMENT**

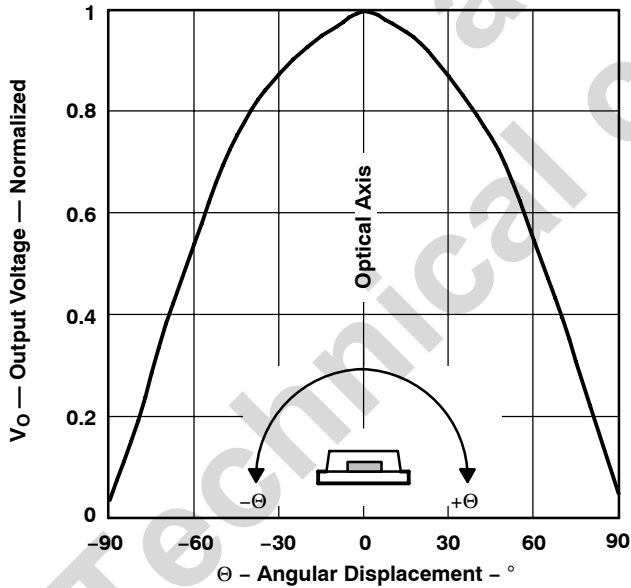

**Figure 5**



**NORMALIZED OUTPUT VOLTAGE**  
**vs.**  
**ANGULAR DISPLACEMENT**

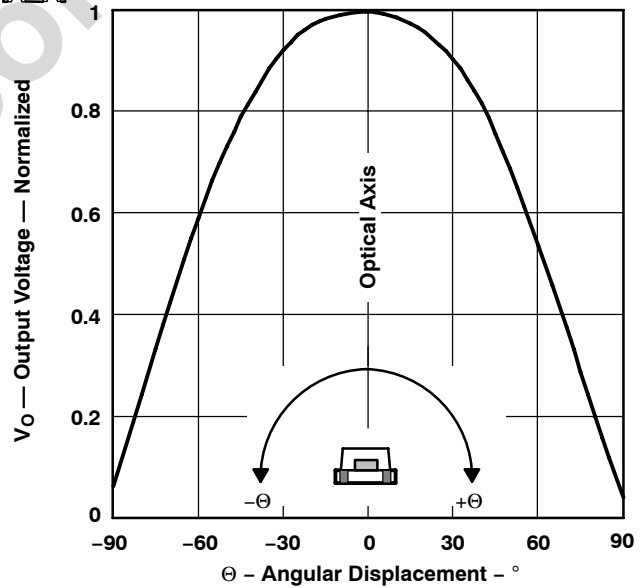
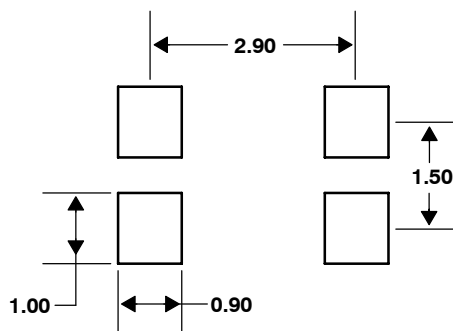

**Figure 6**

APPLICATION INFORMATION

PCB Pad Layout

Suggested PCB pad layout guidelines for the T package are shown in Figure 7.



- NOTES: A. All linear dimensions are in millimeters.  
B. This drawing is subject to change without notice.

Figure 7. Suggested T Package PCB Layout

**TSL257T**  
**HIGH-SENSITIVITY**  
**LIGHT-TO-VOLTAGE CONVERTER**

TAOS065B – APRIL 2007

**MECHANICAL DATA**

The TSL257T is supplied in a low-profile surface-mount package. This package contains no lead (Pb).

**PACKAGE T**

**Four-Lead Surface Mount Device**

**TOP VIEW**

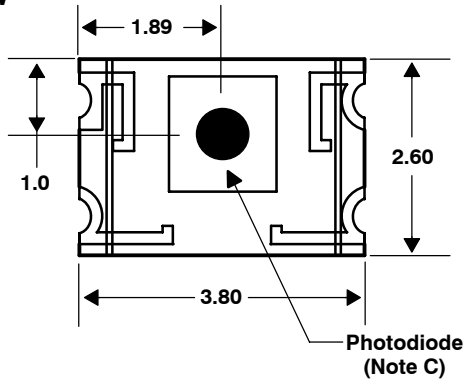

**DETAIL A: TYPICAL PACKAGE TERMINAL**

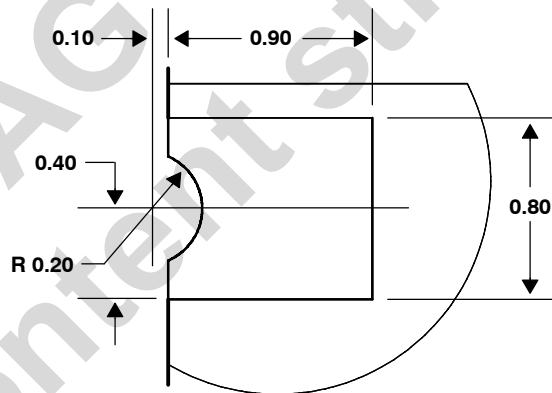

**SIDE VIEW**

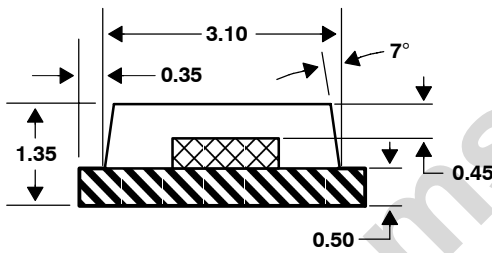

**BOTTOM VIEW**

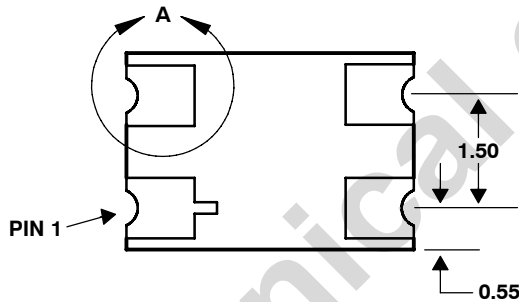

Lead Free

- NOTES: A. All linear dimensions are in millimeters.  
 B. Terminal finish is gold.  
 C. The center of the 0.75 mm diameter integrated photodiode active area is typically located 0.1 mm above the center of the package.  
 D. Dimension tolerance is  $\pm 0.15$  mm.  
 E. This drawing is subject to change without notice.

**Figure 8. Package T — Four-Lead Surface Mount Device Packaging Configuration**



**MECHANICAL DATA**

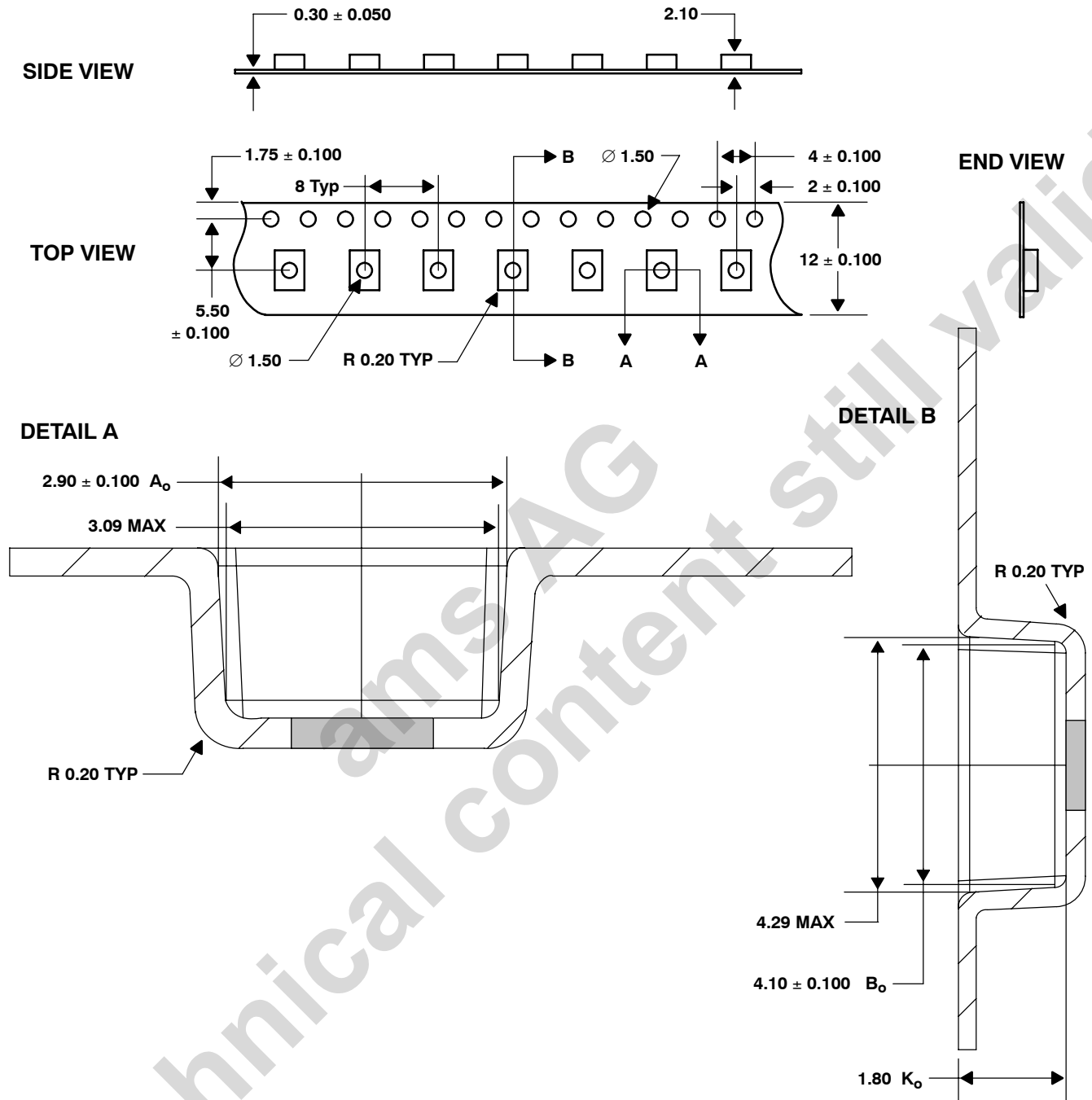

- NOTES:
- All linear dimensions are in millimeters.
  - The dimensions on this drawing are for illustrative purposes only. Dimensions of an actual carrier may vary slightly.
  - Symbols on drawing  $A_o$ ,  $B_o$ , and  $K_o$  are defined in ANSI EIA Standard 481-B 2001.
  - Each reel is 178 millimeters in diameter and contains 1000 parts.
  - TAOS packaging tape and reel conform to the requirements of EIA Standard 481-B.
  - In accordance with EIA standard, device pin 1 is located next to the sprocket holes in the tape.
  - This drawing is subject to change without notice.

**Figure 9. Four Lead Surface Mount Package Carrier Tape**

**TSL257T**  
**HIGH-SENSITIVITY**  
**LIGHT-TO-VOLTAGE CONVERTER**

TAOS065B – APRIL 2007

**MANUFACTURING INFORMATION**

The reflow profile specified here describes expected maximum heat exposure of devices during the solder reflow process of the device on a PWB. Temperature is measured at the top of the device. Devices should be limited to one pass through the solder reflow profile.

**Table 1. TSL257T Solder Reflow Profile**

PARAMETER	REFERENCE	TSL257T
Average temperature gradient in preheating		2.5°C/sec
Soak time	$t_{soak}$	2 to 3 minutes
Time above $T_1$ , 217°C	$t_1$	Max 60 sec
Time above $T_2$ , 230°C	$t_2$	Max 50 sec
Time above $T_3$ , ( $T_{peak} - 10^\circ\text{C}$ )	$t_3$	Max 10 sec
Peak temperature in reflow	$T_{peak}$	260° C (-0°C/+5°C)
Temperature gradient in cooling		Max -5°C/sec

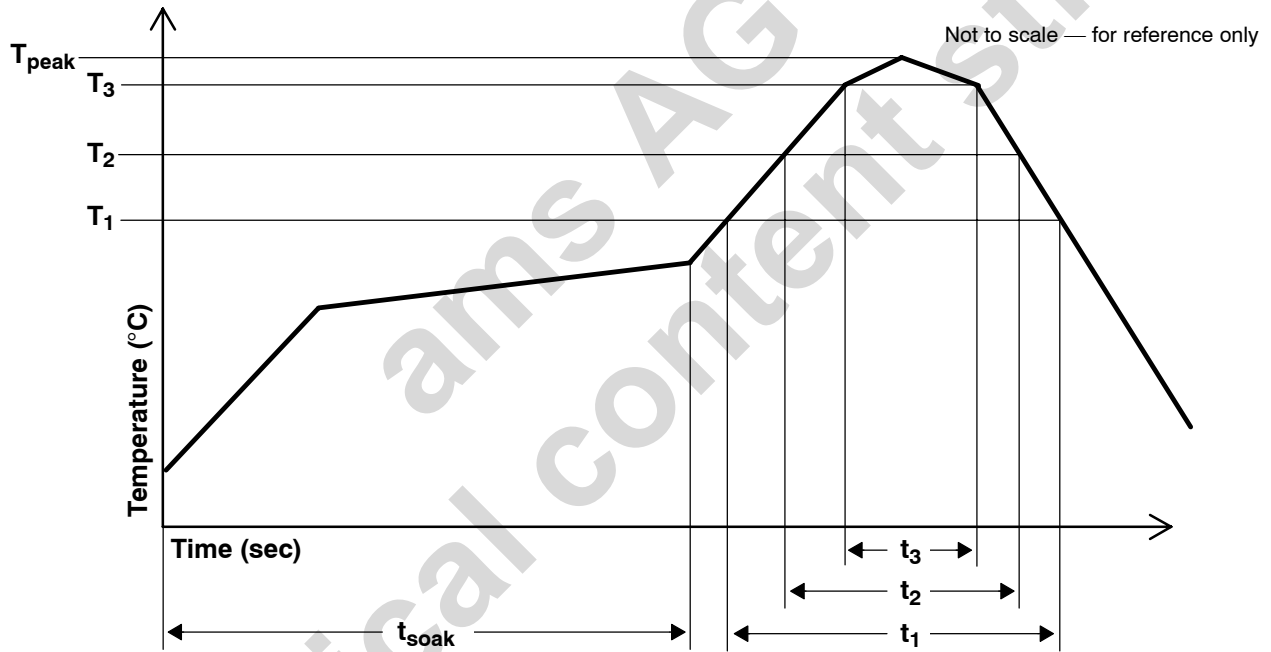

**Figure 10. TSL257T Solder Reflow Profile**

---

## MANUFACTURING INFORMATION

### Moisture Sensitivity

Optical characteristics of the device can be adversely affected during the soldering process by the release and vaporization of moisture that has been previously absorbed into the package molding compound. To ensure the package molding compound contains the smallest amount of absorbed moisture possible, each device is dry-baked prior to being packed for shipping. Devices are packed in a sealed aluminized envelope with silica gel to protect them from ambient moisture during shipping, handling, and storage before use.

This package has been assigned a moisture sensitivity level of MSL 3 and the devices should be stored under the following conditions:

Temperature Range	5°C to 50°C
Relative Humidity	60% maximum
Total Time	6 months from the date code on the aluminized envelope — if unopened
Opened Time	168 hours or fewer

Rebaking will be required if the devices have been stored unopened for more than 6 months or if the aluminized envelope has been open for more than 168 hours. If rebaking is required, it should be done at 90°C for 4 hours.

# TSL257T HIGH-SENSITIVITY LIGHT-TO-VOLTAGE CONVERTER

TAOS065B – APRIL 2007

---

**PRODUCTION DATA** — information in this document is current at publication date. Products conform to specifications in accordance with the terms of Texas Advanced Optoelectronic Solutions, Inc. standard warranty. Production processing does not necessarily include testing of all parameters.

## **LEAD-FREE (Pb-FREE) and GREEN STATEMENT**

**Pb-Free (RoHS)** TAOS' terms *Lead-Free* or *Pb-Free* mean semiconductor products that are compatible with the current RoHS requirements for all 6 substances, including the requirement that lead not exceed 0.1% by weight in homogeneous materials. Where designed to be soldered at high temperatures, TAOS Pb-Free products are suitable for use in specified lead-free processes.

**Green (RoHS & no Sb/Br)** TAOS defines *Green* to mean Pb-Free (RoHS compatible), and free of Bromine (Br) and Antimony (Sb) based flame retardants (Br or Sb do not exceed 0.1% by weight in homogeneous material).

**Important Information and Disclaimer** The information provided in this statement represents TAOS' knowledge and belief as of the date that it is provided. TAOS bases its knowledge and belief on information provided by third parties, and makes no representation or warranty as to the accuracy of such information. Efforts are underway to better integrate information from third parties. TAOS has taken and continues to take reasonable steps to provide representative and accurate information but may not have conducted destructive testing or chemical analysis on incoming materials and chemicals. TAOS and TAOS suppliers consider certain information to be proprietary, and thus CAS numbers and other limited information may not be available for release.

## **NOTICE**

Texas Advanced Optoelectronic Solutions, Inc. (TAOS) reserves the right to make changes to the products contained in this document to improve performance or for any other purpose, or to discontinue them without notice. Customers are advised to contact TAOS to obtain the latest product information before placing orders or designing TAOS products into systems.

TAOS assumes no responsibility for the use of any products or circuits described in this document or customer product design, conveys no license, either expressed or implied, under any patent or other right, and makes no representation that the circuits are free of patent infringement. TAOS further makes no claim as to the suitability of its products for any particular purpose, nor does TAOS assume any liability arising out of the use of any product or circuit, and specifically disclaims any and all liability, including without limitation consequential or incidental damages.

TEXAS ADVANCED OPTOELECTRONIC SOLUTIONS, INC. PRODUCTS ARE NOT DESIGNED OR INTENDED FOR USE IN CRITICAL APPLICATIONS IN WHICH THE FAILURE OR MALFUNCTION OF THE TAOS PRODUCT MAY RESULT IN PERSONAL INJURY OR DEATH. USE OF TAOS PRODUCTS IN LIFE SUPPORT SYSTEMS IS EXPRESSLY UNAUTHORIZED AND ANY SUCH USE BY A CUSTOMER IS COMPLETELY AT THE CUSTOMER'S RISK.

LUMENOLOGY, TAOS, the TAOS logo, and Texas Advanced Optoelectronic Solutions are registered trademarks of Texas Advanced Optoelectronic Solutions Incorporated.