



Chipsmall Limited consists of a professional team with an average of over 10 year of expertise in the distribution of electronic components. Based in Hongkong, we have already established firm and mutual-benefit business relationships with customers from,Europe,America and south Asia,supplying obsolete and hard-to-find components to meet their specific needs.

With the principle of “Quality Parts,Customers Priority,Honest Operation,and Considerate Service”,our business mainly focus on the distribution of electronic components. Line cards we deal with include Microchip,ALPS,ROHM,Xilinx,Pulse,ON,Everlight and Freescale. Main products comprise IC,Modules,Potentiometer,IC Socket,Relay,Connector.Our parts cover such applications as commercial,industrial, and automotives areas.

We are looking forward to setting up business relationship with you and hope to provide you with the best service and solution. Let us make a better world for our industry!



## Contact us

Tel: +86-755-8981 8866 Fax: +86-755-8427 6832

Email & Skype: info@chipsmall.com Web: www.chipsmall.com

Address: A1208, Overseas Decoration Building, #122 Zhenhua RD., Futian, Shenzhen, China



# TSL2771

## Light-to-Digital Converter with Proximity Sensing

### General Description

The TSL2771 family of devices provides both ambient light sensing (ALS) and proximity detection (when coupled with an external IR LED). The ALS approximates human eye response to light intensity under a variety of lighting conditions and through a variety of attenuation materials. The proximity detection feature allows a large dynamic range of operation for use in short distance detection behind dark glass such as in a cell phone or for longer distance measurements for applications such as presence detection for monitors or laptops. The programmable proximity detection enables continuous measurements across the entire range. In addition, an internal state machine provides the ability to put the device into a low power mode in between ALS and proximity measurements providing very low average power consumption.

While useful for general purpose light sensing, the device is particularly useful for display management with the purpose of extending battery life and providing optimum viewing in diverse lighting conditions. Display panel and keyboard backlighting can account for up to 30 to 40 percent of total platform power. The ALS features are ideal for use in tablets, notebook PCs, LCD monitors, flat-panel televisions, and cell phones.

The proximity function is targeted specifically towards cell phone, LCD monitor, laptop, and flat-panel television applications. In cell phones, the proximity detection can detect when the user positions the phone close to their ear. The device is fast enough to provide proximity information at a high repetition rate needed when answering a phone call. It can also detect both close and far distances so the application can implement more complex algorithms to provide a more robust interface. In laptop or monitor applications, the product is sensitive enough to determine whether a user is in front of the laptop using the keyboard or away from the desk. This provides both improved *green* power saving capability and the added security to lock the computer when the user is not present.

*Ordering Information and Content Guide appear at end of datasheet.*

## Key Benefits & Features

The benefits and features of TSL2771, Light-to-Digital Converter with Proximity Sensing are listed below:

**Figure 1:**  
**Added Value of Using TSL2771**

Benefits	Features
<ul style="list-style-type: none"> <li>Enables Operation in IR Light Environments</li> </ul>	<ul style="list-style-type: none"> <li>Patented Dual-Diode Architecture</li> </ul>
<ul style="list-style-type: none"> <li>Enables Operation in 10k Lux Sunlight and Accurate Sensing Behind Spectrally Distorting Materials</li> </ul>	<ul style="list-style-type: none"> <li>1M:1 Dynamic Range</li> </ul>
<ul style="list-style-type: none"> <li>Allows Multiple Power-Level Selection Without External Passives</li> </ul>	<ul style="list-style-type: none"> <li>Programmable LED Drive Current</li> </ul>
<ul style="list-style-type: none"> <li>Reduces Micro-Processor Interrupt Overhead</li> </ul>	<ul style="list-style-type: none"> <li>Programmable Interrupt Function</li> </ul>
<ul style="list-style-type: none"> <li>Reduces board Space Requirements while Simplifying Designs</li> </ul>	<ul style="list-style-type: none"> <li>Area Efficient 2mm x 2mm Dual Flat No-Lead (FN) Package</li> </ul>

- Ambient Light Sensing and Proximity Detection in a Single Device
- Ambient Light Sensing (ALS)
  - Approximates Human Eye Response
  - Programmable Analog Gain
  - Programmable Integration Time
  - Programmable Interrupt Function with Upper and Lower Threshold
  - Resolution Up to 16 Bits
  - Very High Sensitivity — Operates Well Behind Darkened Glass
  - Up to 1,000,000:1 Dynamic Range
- Proximity Detection
  - Programmable Number of IR Pulses
  - Programmable Current Sink for the IR LED — No Limiting Resistor Needed
  - Programmable Interrupt Function with Upper and Lower Threshold
  - Covers a 2000:1 Dynamic Range
- Programmable Wait Timer
  - Programmable from 2.72 ms to > 8 Seconds
  - Wait State — 65 mA Typical Current
- I<sup>2</sup>C Interface Compatible
  - Up to 400 kHz (I<sup>2</sup>C Fast Mode)
  - Dedicated Interrupt Pin
- Sleep Mode – 2.5 mA Typical Current

### Applications

TSL2771, Light-to-Digital Converter with Proximity Sensing is ideal for:

- Cell Phone Backlight Dimming
- Cell Phone Touch Screen Disable
- Notebook/Monitor Security
- Automatic Speakerphone Enable
- Automatic Menu Popup

### Functional Block Diagram

The functional blocks of this device are shown below:

Figure 2:  
TSL2771 Block Diagram

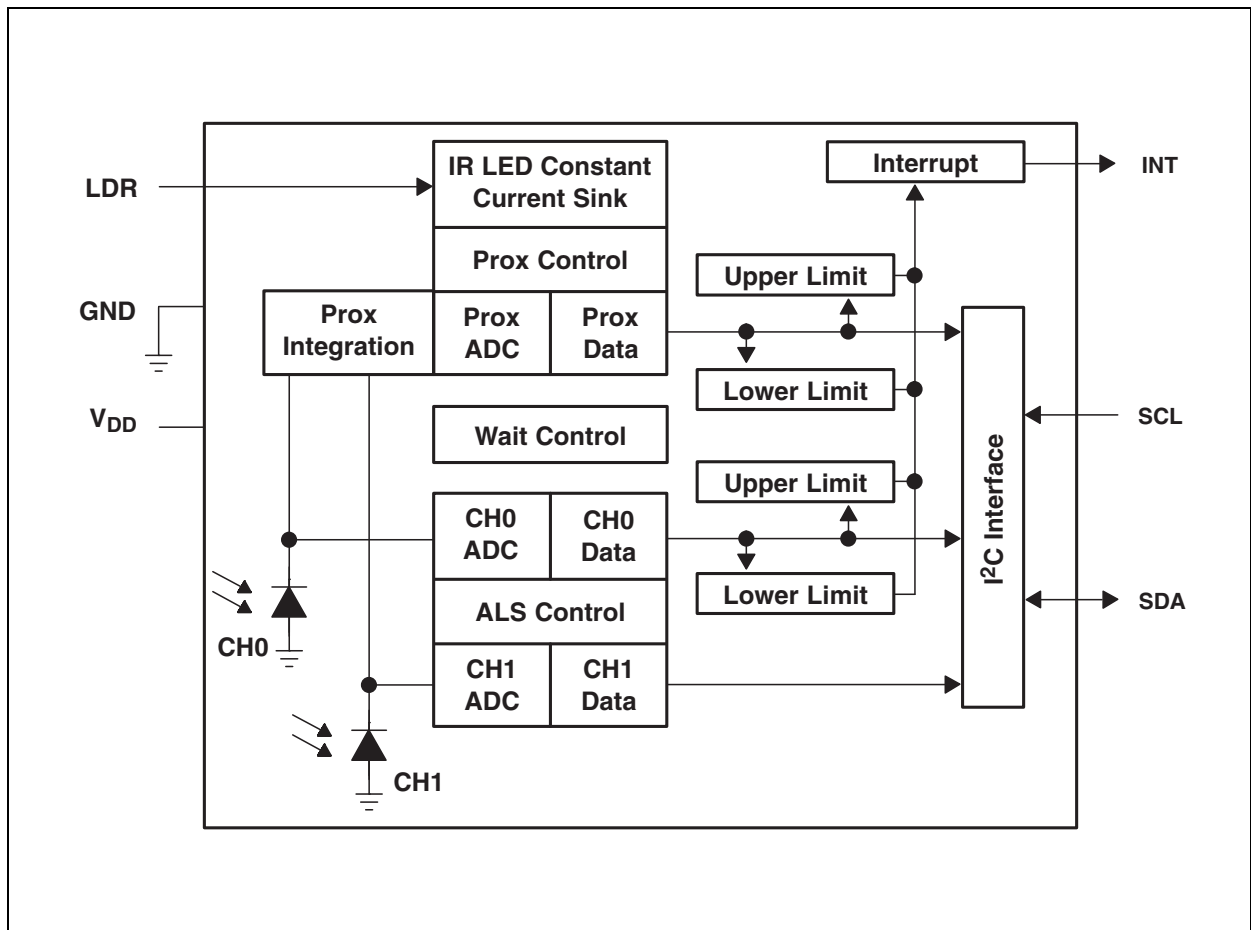



## Detailed Description

The TSL2771 light-to-digital device provides on-chip photodiodes, integrating amplifiers, ADCs, accumulators, clocks, buffers, comparators, a state machine, and an I<sup>2</sup>C interface. Each device combines a Channel 0 photodiode (CH0), which is responsive to both visible and infrared light, and a channel 1 photodiode (CH1), which is responsive primarily to infrared light. Two integrating ADCs simultaneously convert the amplified photodiode currents into a digital value providing up to 16 bits of resolution. Upon completion of the conversion cycle, the conversion result is transferred to the data registers. This digital output can be read by a microprocessor through which the illuminance (ambient light level) in Lux is derived using an empirical formula to approximate the human eye response.

Communication to the device is accomplished through a fast (up to 400 kHz), two-wire I<sup>2</sup>C serial bus for easy connection to a microcontroller or embedded controller. The digital output of the device is inherently more immune to noise when compared to an analog interface.

The device provides a separate pin for level-style interrupts. When interrupts are enabled and a pre-set value is exceeded, the interrupt pin is asserted and remains asserted until cleared by the controlling firmware. The interrupt feature simplifies and improves system efficiency by eliminating the need to poll a sensor for a light intensity or proximity value. An interrupt is generated when the value of an ALS or proximity conversion exceeds either an upper or lower threshold. In addition, a programmable interrupt persistence feature allows the user to determine how many consecutive exceeded thresholds are necessary to trigger an interrupt. Interrupt thresholds and persistence settings are configured independently for both ALS and proximity.

Proximity detection requires only a single external IR LED. An internal LED driver can be configured to provide a constant current sink of 12.5 mA, 25 mA, 50 mA, or 100 mA of current. No external current limiting resistor is required. The number of proximity LED pulses can be programmed from 1 to 255 pulses. Each pulse has a 16- $\mu$ s period. This LED current, coupled with the programmable number of pulses, provides a 2000:1 contiguous dynamic range.

## Pin Assignments

The TSL2771 pin assignments are described below:

**Figure 3:**  
Package FN Dual Flat No-Lead (Top View)

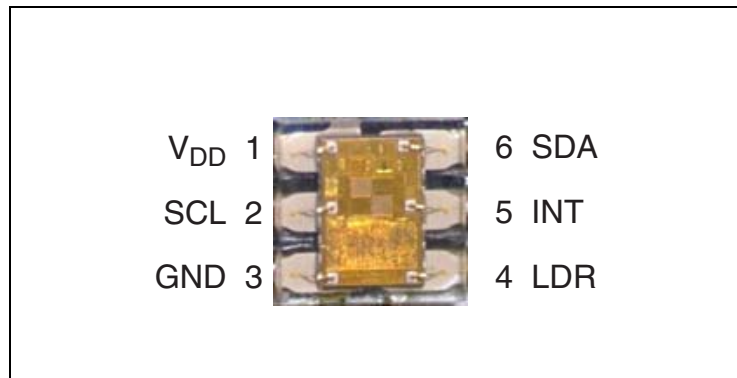

**Figure 4:**  
Terminal Functions

Terminal		Type	Description
Name	No		
V <sub>DD</sub>	1		Supply voltage.
SCL	2	I	I <sup>2</sup> C serial clock input terminal — clock signal for I <sup>2</sup> C serial data.
GND	3		Power supply ground. All voltages are referenced to GND.
LDR	4	O	LED driver for proximity emitter — up to 100 mA, open drain.
INT	5	O	Interrupt — open drain (active low).
SDA	6	I/O	I <sup>2</sup> C serial data I/O terminal — serial data I/O for I <sup>2</sup> C

## Absolute Maximum Ratings

Stresses beyond those listed under [Absolute Maximum Ratings](#) may cause permanent damage to the device. These are stress ratings only, and functional operation of the device at these or any other conditions beyond those indicated under [Recommended Operating Conditions](#) is not implied. Exposure to absolute-maximum-rated conditions for extended periods may affect device reliability.

**Figure 5:**  
**Absolute Maximum Ratings Over Operating Free-Air Temperature Range (unless otherwise noted)**

Symbol	Parameter	Min	Max	Units
$V_{DD}^{(1)}$	Supply voltage		3.8	V
$V_O$	Digital output voltage range	-0.5	3.8	V
$I_O$	Digital output current	-1	20	mA
$T_{stg}$	Storage temperature range	-40	85	°C
$ESD_{HBM}$	ESD tolerance, human body model	±2000		V

**Note(s):**

1. All voltages are with respect to GND.

**Figure 6:**  
**Recommended Operating Conditions**

Symbol	Parameter	Min	Nom	Max	Unit
$V_{DD}$	Supply voltage	2.6	3	3.6	V
$T_A$	Operating free-air temperature	-30		70	°C

**Figure 7:**  
**Operating Characteristics;  $V_{DD} = 3\text{ V}$ ,  $T_A = 25^\circ\text{C}$  (unless otherwise noted)**

Symbol	Parameter	Test Conditions	Min	Typ	Max	Unit
$I_{DD}$	Supply current	Active — LDR pulse OFF		175	250	$\mu\text{A}$
		Wait mode		65		
		Sleep mode - no I <sup>2</sup> C activity		2.5	4	
$V_{OL}$	INT, SDA output low voltage	3 mA sink current	0		0.4	V
		6 mA sink current	0		0.6	
$I_{LEAK}$	Leakage current, SDA, SCL, INT pins		-5		5	$\mu\text{A}$
$I_{LEAK}$	Leakage current, LDR pin			$\pm 10$		$\mu\text{A}$
$V_{IH}$	SCL, SDA input high voltage	TSL27711, TSL27715	$0.7V_{DD}$			V
		TSL27713, TSL27717	1.25			
$V_{IL}$	SCL, SDA input low voltage	TSL27711, TSL27715			$0.3V_{DD}$	V
		TSL27713, TSL27717			0.54	



**Figure 8:**
**ALS Characteristics;  $V_{DD} = 3\text{ V}$ ,  $T_A = 25^\circ\text{C}$ , Gain = 16, AEN = 1 (unless otherwise noted) <sup>(1)</sup> <sup>(2)</sup> <sup>(3)</sup>**

Parameter	Test Conditions	Channel	Min	Typ	Max	Unit
Dark ADC count value	$E_e = 0$ , AGAIN = 120x, ATIME = 0xDB (100 ms)	CH0	0	1	5	counts
		CH1	0	1	5	
ADC integration time step size	ATIME = 0xFF		2.58	2.72	2.9	ms
ADC Number of integration steps			1		256	steps
ADC counts per step	ATIME = 0xFF		0		1024	counts
ADC count value	ATIME = 0xC0		0		65535	counts
ADC count value	$\lambda_p = 625\text{ nm}$ , $E_e = 171.6\ \mu\text{W}/\text{cm}^2$ , ATIME = 0xF6 (27 ms) <sup>(2)</sup>	CH0	4000	5000	6000	counts
		CH1		790		
	$\lambda_p = 850\text{ nm}$ , $E_e = 219.7\ \mu\text{W}/\text{cm}^2$ , ATIME = 0xF6 (27 ms) <sup>(3)</sup>	CH0	4000	5000	6000	
		CH1		2800		
ADC count value ratio: CH1/CH0	$\lambda_p = 625\text{ nm}$ , ATIME 0xF6 (27 ms) <sup>(2)</sup>		10.8	15.8	20.8	%
	$\lambda_p = 850\text{ nm}$ , ATIME 0xF6 (27 ms) <sup>(3)</sup>		41	56	68	
$R_e$ Irradiance responsivity	$\lambda_p = 625\text{ nm}$ , ATIME = 0xF6 (27 ms) <sup>(2)</sup>	CH0		29.1		counts/ ( $\mu\text{W}/\text{cm}^2$ )
		CH1		4.6		
	$\lambda_p = 850\text{ nm}$ , ATIME = 0xF6 (27 ms) <sup>(3)</sup>	CH0		22.8		
		CH1		12.7		
Gain scaling, relative to 1x gain setting	8x		-10		10	%
	16x		-10		10	
	120x		-10		10	

**Note(s):**

- Optical measurements are made using small-angle incident radiation from light-emitting diode optical sources. Visible 625 nm LEDs and infrared 850 nm LEDs are used for final product testing for compatibility with high-volume production.
- The 625 nm irradiance  $E_e$  is supplied by an AlInGaP light-emitting diode with the following typical characteristics: peak wavelength  $\lambda_p = 625\text{ nm}$  and spectral halfwidth  $\Delta\lambda_{1/2} = 20\text{ nm}$ .
- The 850 nm irradiance  $E_e$  is supplied by a GaAs light-emitting diode with the following typical characteristics: peak wavelength  $\lambda_p = 850\text{ nm}$  and spectral halfwidth  $\Delta\lambda_{1/2} = 42\text{ nm}$ .

**Figure 9:**  
**Proximity Characteristics;  $V_{DD} = 3\text{ V}$ ,  $T_A = 25^\circ\text{C}$ , PEN = 1 (unless otherwise noted)**

Parameter	Test Conditions	Condition	Min	Typ	Max	Unit
$I_{DD}$ Supply current	LDR pulse ON			3		mA
ADC conversion time step size	PTIME = 0xFF		2.58	2.72	2.9	ms
ADC number of integration steps			1		256	steps
ADC counts per step	PTIME = 0xFF		0		1023	counts
IR LED pulse count			0		255	pulses
pulse period	Two or more pulses			16		$\mu\text{s}$
LED pulse width — LED ON time				7.3		$\mu\text{s}$
LED drive current	$I_{SINK}$ sink current @ 600 mV, LDR pin	PDRIVE=0	75	100	125	mA
		PDRIVE=1		50		
		PDRIVE=2		25		
		PDRIVE=3		12.5		
Operating distance <sup>(1)</sup>				18		inches

**Note(s):**

1. Proximity Operating Distance is dependent upon emitter properties and the reflective properties of the proximity surface. The nominal value shown uses an IR emitter with a peak wavelength of 850nm and a 20° half angle. The proximity surface used is a 90% reflective (white surface) 16 × 20-inch Kodak Gray Card. 60 mw/SR, 100 mA, 64 pulses, open view (no glass). **Note:** Greater distances are achievable with appropriate system considerations.

**Figure 10:**  
**Wait Characteristics;  $V_{DD} = 3\text{ V}$ ,  $T_A = 25^\circ\text{C}$ , WEN = 1 (unless otherwise noted)**

Parameter	Test Conditions	Channel	Min	Typ	Max	Unit
Wait step size	WTIME = 0xFF		2.58	2.72	2.9	ms
Wait number of integration steps			1		256	steps

**Figure 11:**  
**AC Electrical Characteristics;  $V_{DD} = 3\text{ V}$ ,  $T_A = 25^\circ\text{C}$ , (unless otherwise noted)**

Symbol	Parameter <sup>(1)</sup>	Test Conditions	Min	Typ	Max	Unit
$f_{(SCL)}$	Clock frequency (I <sup>2</sup> C only)		0		400	kHz
$t_{(BUF)}$	Bus free time between start and stop condition		1.3			$\mu\text{s}$
$t_{(HDSTA)}$	Hold time after (repeated) start condition. After this period, the first clock is generated.		0.6			$\mu\text{s}$
$t_{(SUSTA)}$	Repeated start condition setup time		0.6			$\mu\text{s}$
$t_{(SUSTO)}$	Stop condition setup time		0.6			$\mu\text{s}$
$t_{(HDDAT)}$	Data hold time		0			$\mu\text{s}$
$t_{(SUDAT)}$	Data setup time		100			ns
$t_{(LOW)}$	SCL clock low period		1.3			$\mu\text{s}$
$t_{(HIGH)}$	SCL clock high period		0.6			$\mu\text{s}$
$t_F$	Clock/data fall time				300	ns
$t_R$	Clock/data rise time				300	ns
$C_i$	Input pin capacitance				10	pF

**Note(s):**

1. Specified by design and characterization; not production tested.

### Parameter Measurement Information

**Figure 12:**  
Timing Diagrams

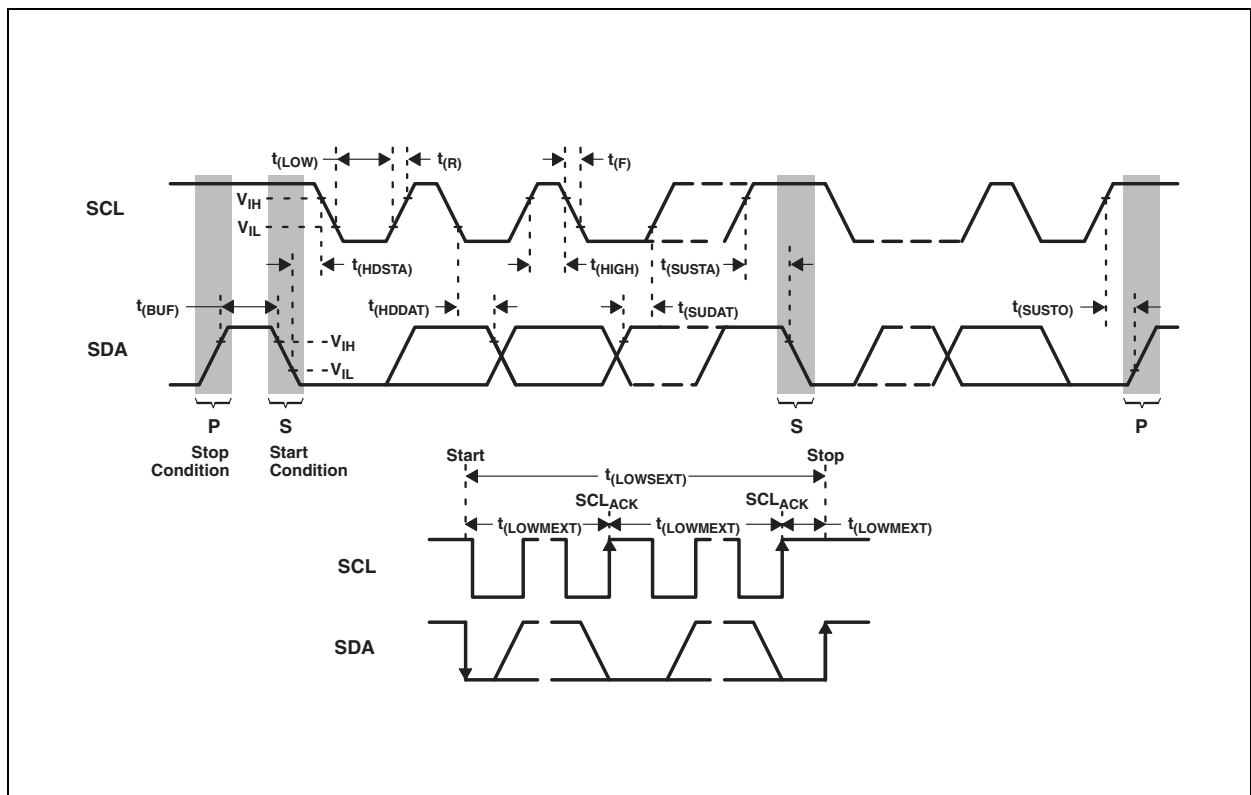

Typical Operating Characteristics

Figure 13: Spectral Responsivity

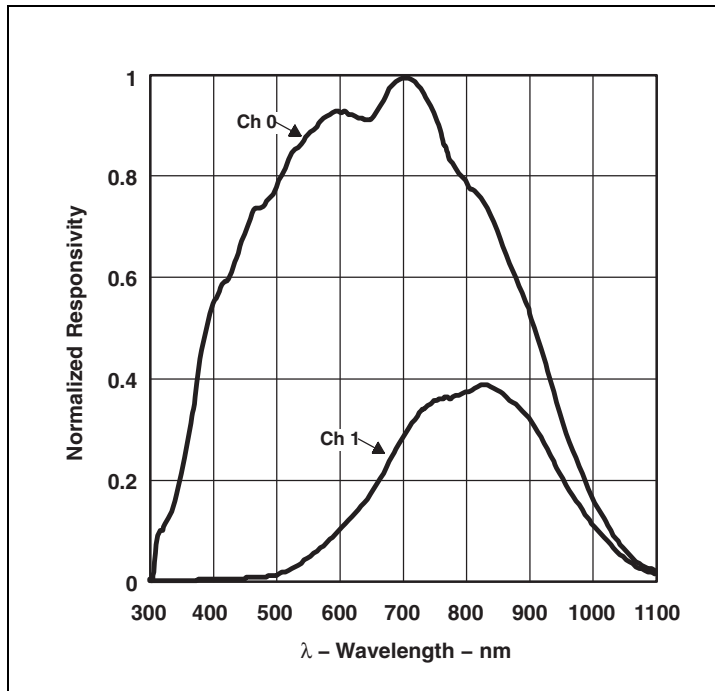
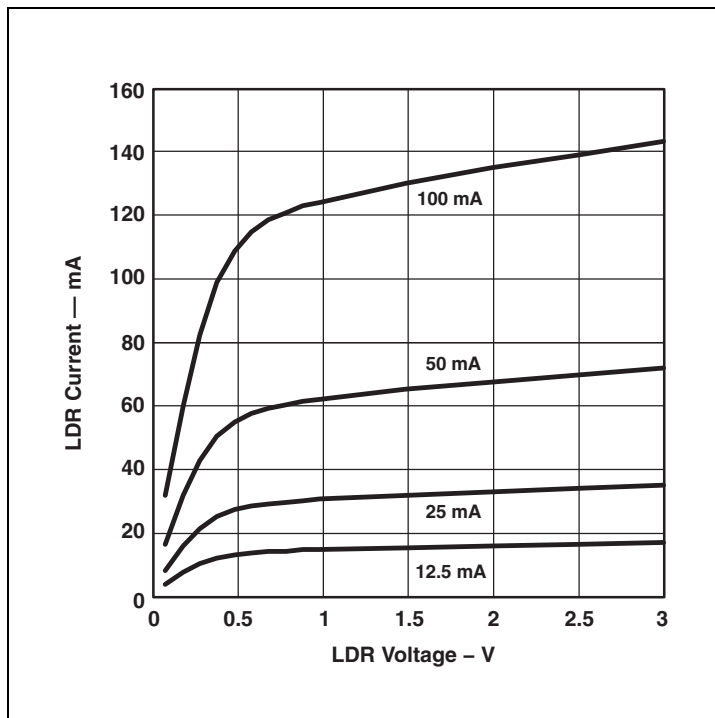
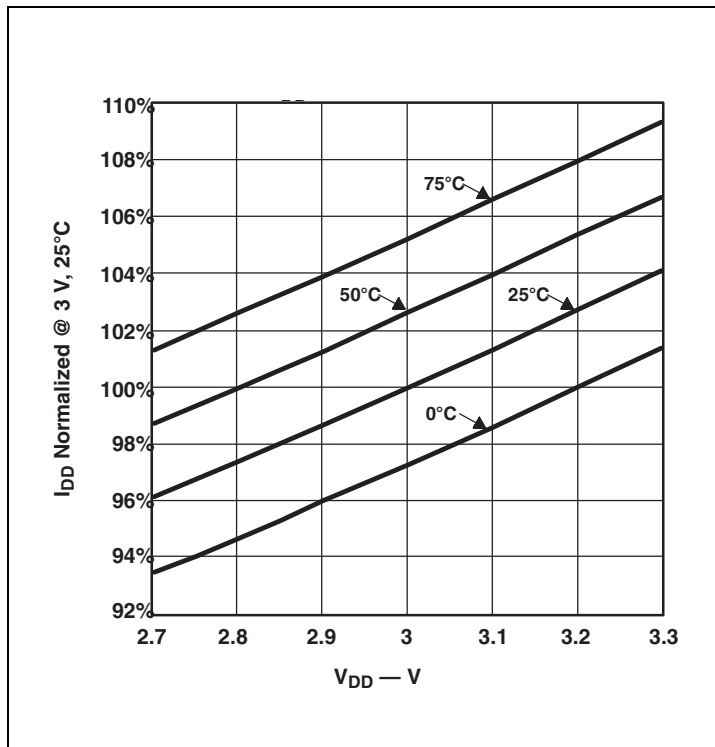

Figure 14: Typical LDR Current vs. Voltage



**Figure 15:**  
Normalized  $I_{DD}$  vs.  $V_{DD}$  and Temperature



**Figure 16:**  
Normalized Responsivity vs. Angular Displacement

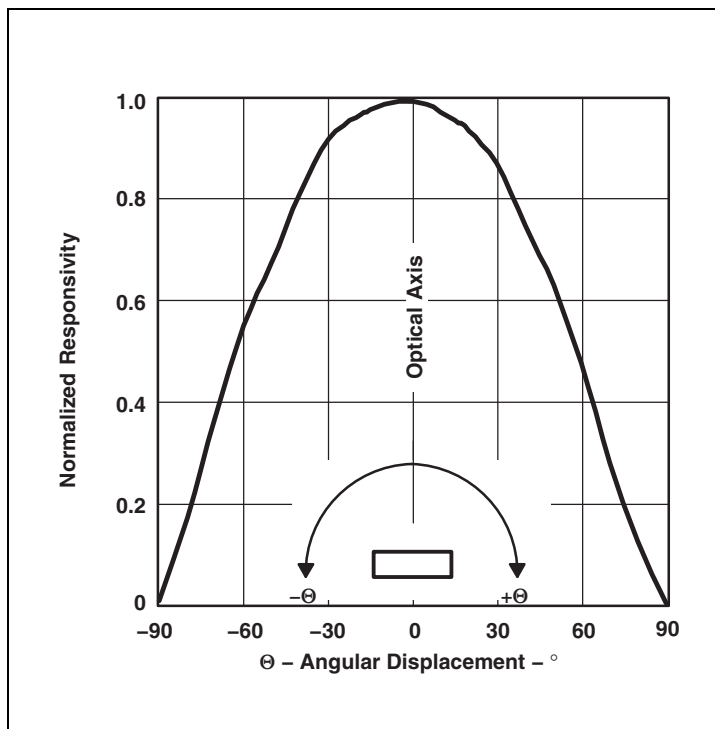



## Principles Of Operation

### System State Machine

The device provides control of ALS, proximity detection, and power management functionality through an internal state machine (Figure 17). After a power-on-reset, the device is in the sleep mode. As soon as the PON bit is set, the device will move to the start state. It will then continue through the Prox, Wait, and ALS states. If these states are enabled, the device will execute each function. If the PON bit is set to 0, the state machine will continue until all conversions are completed and then go into a low power sleep mode.

**Figure 17:**  
Simplified State Diagram

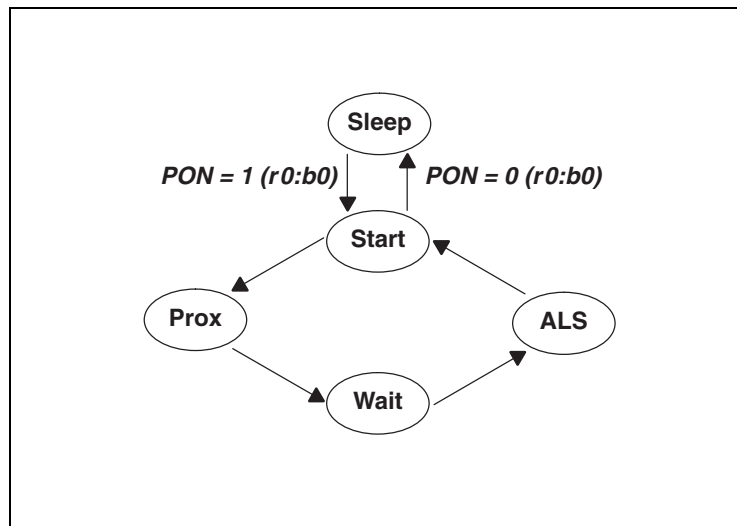

**Note(s):** In this document, the nomenclature uses the bit field name in italics followed by the register number and bit number to allow the user to easily identify the register and bit that controls the function. For example, the power ON (PON) is in register 0, bit 0. This is represented as *PON (r0:b0)*.

### Photodiodes

Conventional silicon detectors respond strongly to infrared light, which the human eye does not see. This can lead to significant error when the infrared content of the ambient light is high (such as with incandescent lighting) due to the difference between the silicon detector response and the brightness perceived by the human eye.

This problem is overcome through the use of two photodiodes. The Channel 0 photodiode, referred to as the CH0 channel, is sensitive to both visible and infrared light, while the Channel 1 photodiode, referred to as CH1, is sensitive primarily to infrared light. Two integrating ADCs convert the photodiode currents to digital outputs. The ADC digital outputs from the two channels are used in a formula to obtain a value that approximates the human eye response in units of lux.

### ALS Operation

The ALS engine contains ALS gain control (AGAIN) and two integrating analog-to-digital converters (ADC) for the Channel 0 and Channel 1 photodiodes. The ALS integration time (ATIME) impacts both the resolution and the sensitivity of the ALS reading. Integration of both channels occurs simultaneously and upon completion of the conversion cycle, the results are transferred to the data registers (C0DATA and C1DATA). This data is also referred to as channel *count*. The transfers are double-buffered to ensure data integrity.

Figure 18:  
ALS Operation

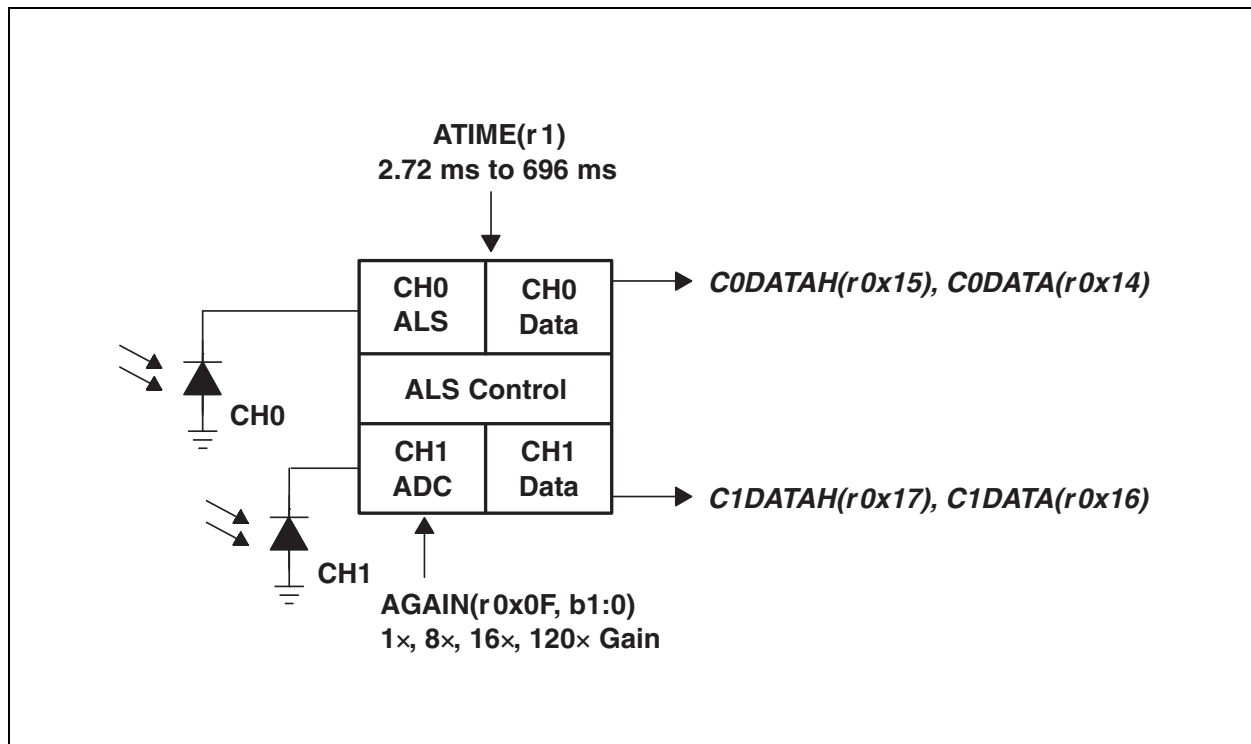

The registers for programming the integration and wait times are a 2's complement values. The actual time can be calculated as follows:

$$\text{ATIME} = 256 - \text{Integration Time} / 2.72 \text{ ms}$$

Inversely, the time can be calculated from the register value as follows:

$$\text{Integration Time} = 2.72 \text{ ms} \times (256 - \text{ATIME})$$

In order to reject 50/60-Hz ripple strongly present in fluorescent lighting, the integration time needs to be programmed in multiples of 10 / 8.3 ms or the half cycle time. Both frequencies can be rejected with a programmed value of 50 ms (ATIME = 0xED) or multiples of 50 ms (i.e. 100, 150, 200, 400, 600).

The registers for programming the AGAIN hold a two-bit value representing a gain of 1x, 8x, 16x, or 120x. The gain, in terms of amount of gain, will be represented by the value AGAINx, i.e. AGAINx = 1, 8, 16, or 120.

### Lux Equation

The lux calculation is a function of CH0 channel count (C0DATA), CH1 channel count (C1DATA), ALS gain (AGAINx), and ALS integration time in milliseconds (ATIME\_ms). If an aperture, glass/plastic, or a light pipe attenuates the light equally across the spectrum (300 nm to 1100 nm), then a scaling factor referred to as glass attenuation (GA) can be used to compensate for attenuation. For a device in open air with no aperture or glass/plastic above the device, GA = 1. If it is not spectrally flat, then a custom lux equation with new coefficients should be generated. (See **ams** application note).

Counts per Lux (CPL) needs to be calculated only when ATIME or AGAIN is changed, otherwise it remains a constant. The first segment of the equation (Lux1) covers fluorescent and incandescent light. The second segment (Lux2) covers dimmed incandescent light. The final lux is the maximum of Lux1, Lux2, or 0.

$$\text{CPL} = (\text{ATIME\_ms} \times \text{AGAINx}) / (\text{GA} \times 53)$$

$$\text{Lux1} = (\text{C0DATA} - 2 \times \text{C1DATA}) / \text{CPL}$$

$$\text{Lux2} = (0.6 \times \text{C0DATA} - \text{C1DATA}) / \text{CPL}$$

$$\text{Lux} = \text{MAX}(\text{Lux1}, \text{Lux2}, 0)$$

### Proximity Detection

Proximity sensing uses an external light source (generally an infrared emitter) to emit light, which is then viewed by the integrated light detector to measure the amount of reflected light when an object is in the light path (Figure 19). The amount of light detected from a reflected surface can then be used to determine an object’s proximity to the sensor.

Figure 19: Proximity Detection

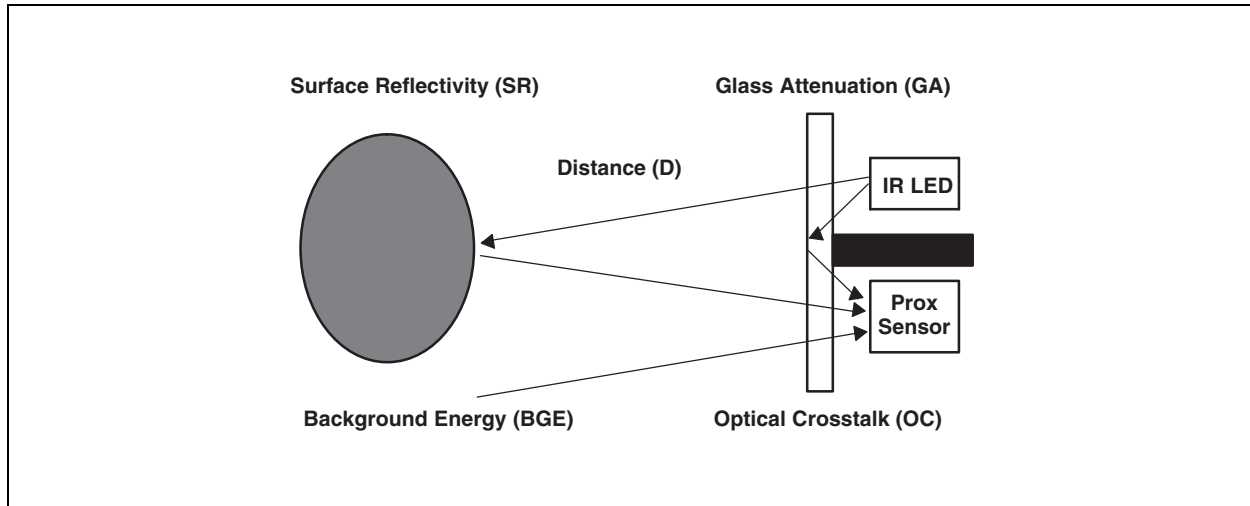

The device has controls for the number of IR pulses (PPCOUNT), the integration time (PTIME), the LED drive current (PDRIVE), and the photodiode configuration (PDIODE) (Figure 20). The photodiode configuration can be set to CH1 diode (recommended), CH0 diode, or a combination of both diodes. At the end of the integration cycle, the results are latched into the proximity data (PDATA) register.

Figure 20: Proximity Detection Operation

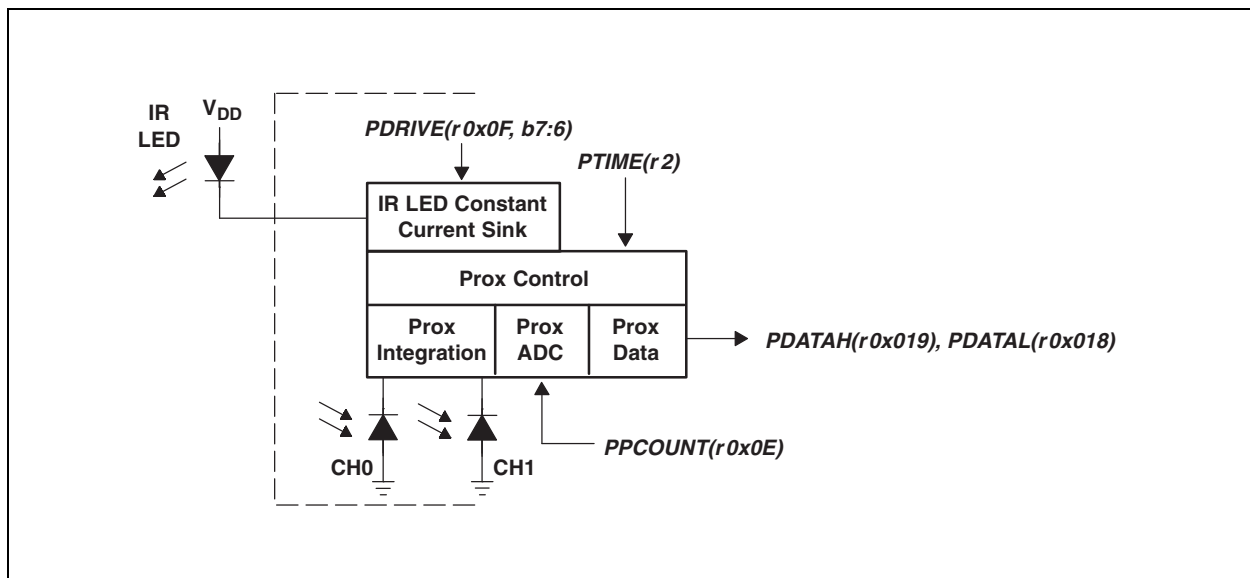

The LED drive current is controlled by a regulated current sink on the LDR pin. This feature eliminates the need to use a current limiting resistor to control LED current. The LED drive current can be configured for 12.5 mA, 25 mA, 50 mA, or 100 mA. For higher LED drive requirements, an external P type transistor can be used to control the LED current.

The number of LED pulses can be programmed to any value between 1 and 255 pulses as needed. Increasing the number of LED pulses at a given current will increase the sensor sensitivity. Sensitivity grows by the square root of the number of pulses. Each pulse has a 16- $\mu$ s period.

**Figure 21:**  
Proximity IR LED Waveform

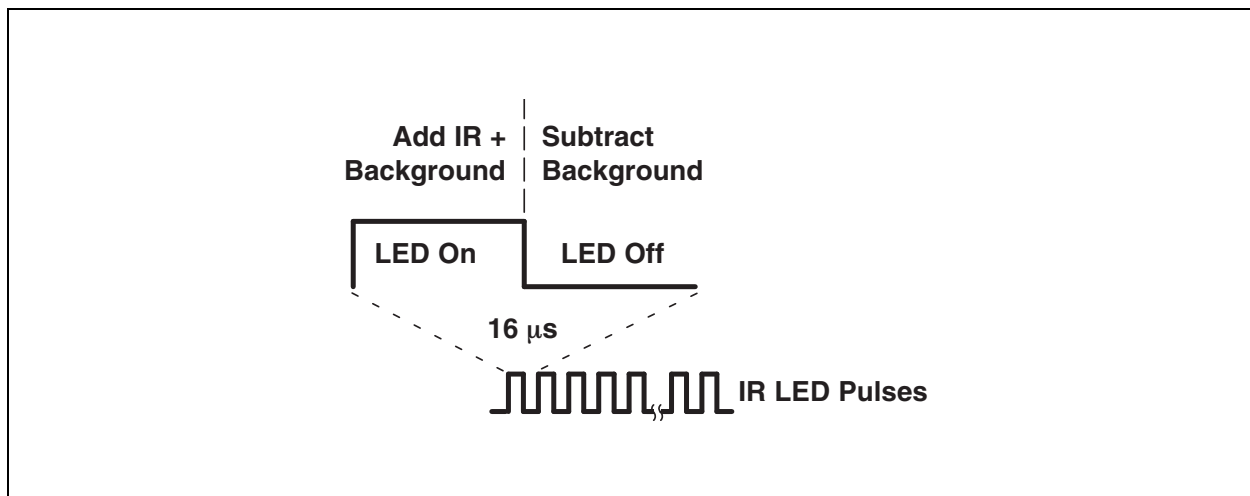

The proximity integration time (PTIME) is the period of time that the internal ADC converts the analog signal to a digital count. It is recommended that this be set to a minimum of PTIME = 0xFF or 2.72 ms.

The combination of LED power and number of pulses can be used to control the distance at which the sensor can detect proximity. Figure 22 shows an example of the distances covered with settings such that each curve covers 2x the distance. Counts up to 64 pulses provide a 16x range.

**Figure 22:**  
Proximity ADC Count vs. Relative Distance

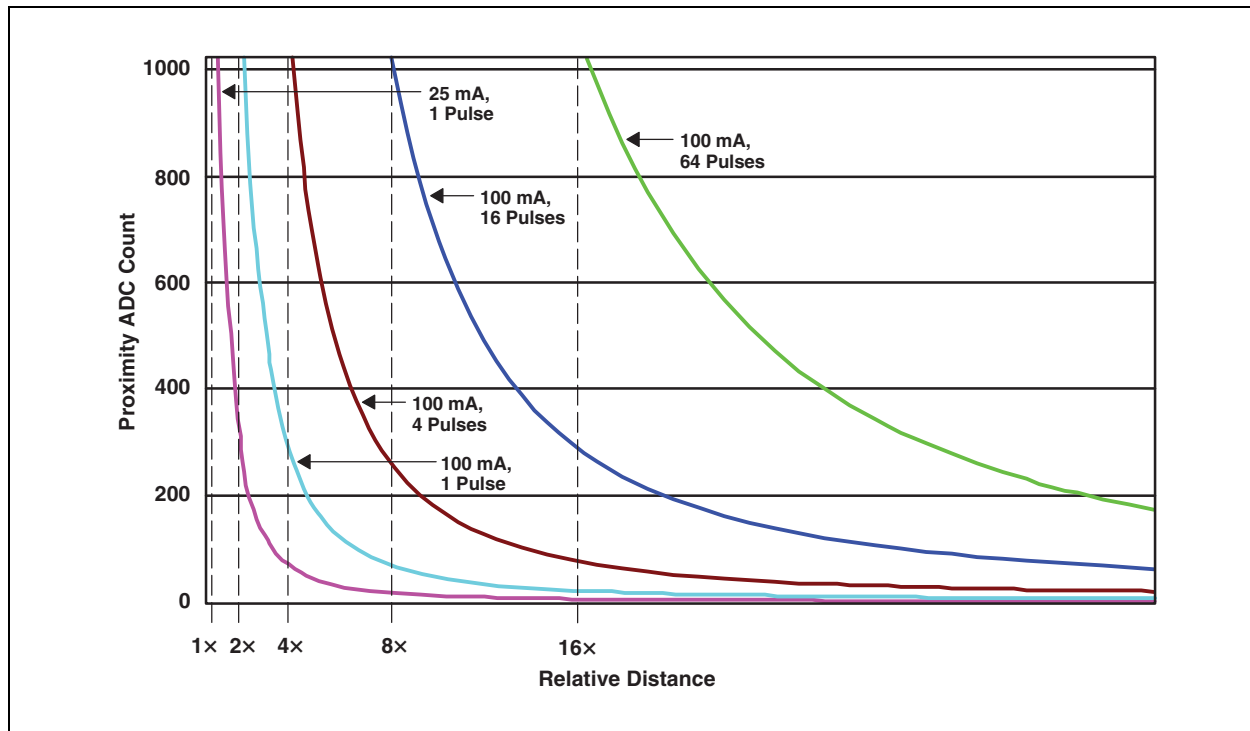

## Interrupts

The interrupt feature simplifies and improves system efficiency by eliminating the need to poll the sensor for light intensity or proximity values outside of a user-defined range. While the interrupt function is always enabled and its status is available in the status register (0x13), the output of the interrupt state can be enabled using the proximity interrupt enable (PIEN) or ALS interrupt enable (AIEN) fields in the enable register (0x00).

Four 16-bit interrupt threshold registers allow the user to set limits below and above a desired light level and proximity range. An interrupt can be generated when the ALS CH0 data (C0DATA) falls outside of the desired light level range, as determined by the values in the ALS interrupt low threshold registers (AILTx) and ALS interrupt high threshold registers (AIHTx). Likewise, an out-of-range proximity interrupt can be generated when the proximity data (PDATA) falls below the proximity interrupt low threshold (PILTx) or exceeds the proximity interrupt high threshold (PIHTx). It is important to note that the low threshold value must be less than the high threshold value for proper operation.

To further control when an interrupt occurs, the device provides a persistence filter. The persistence filter allows the user to specify the number of consecutive out-of-range ALS or proximity occurrences before an interrupt is generated. The persistence register (0x0C) allows the user to set the ALS persistence (APERS) and the proximity persistence (PPERS) values. See the persistence register for details on the persistence filter values. Once the persistence filter generates



an interrupt, it will continue until a special function interrupt clear command is received (see [Command Register](#)).

**Figure 23:**  
Programmable Interrupt

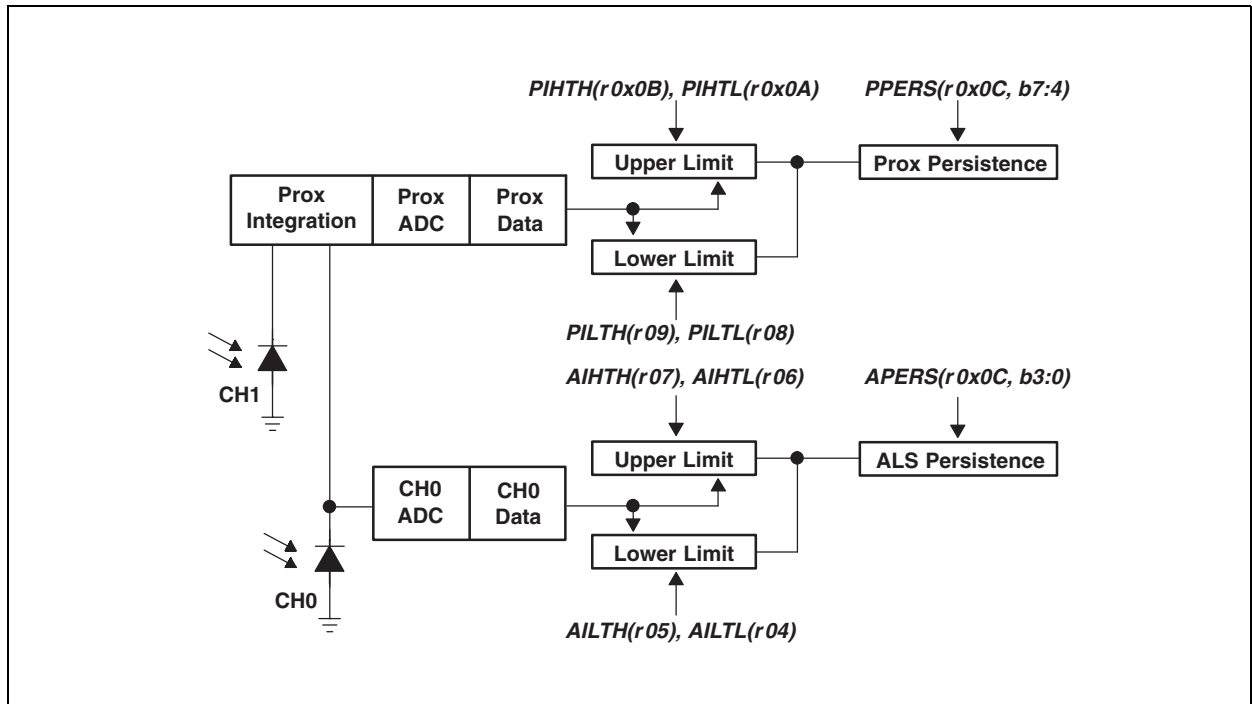

### State Diagram

Figure 24 shows a more detailed flow for the state machine. The device starts in the sleep mode. The PON bit is written to enable the device. A 2.72-ms delay will occur before entering the start state. If the PEN bit is set, the state machine will step through the proximity states of proximity accumulate and then proximity ADC conversion. As soon as the conversion is complete, the state machine will move to the following state.

If the WEN bit is set, the state machine will then cycle through the wait state. If the WLONG bit is set, the wait cycles are extended by 12x over normal operation. When the wait counter terminates, the state machine will step to the ALS state.

The AEN should always be set, even in proximity-only operation. In this case, a minimum of 1 integration time step should be programmed. The ALS state machine will continue until it reaches the terminal count at which point the data will be latched in the ALS register and the interrupt set, if enabled.

Figure 24:  
Expanded State Diagram

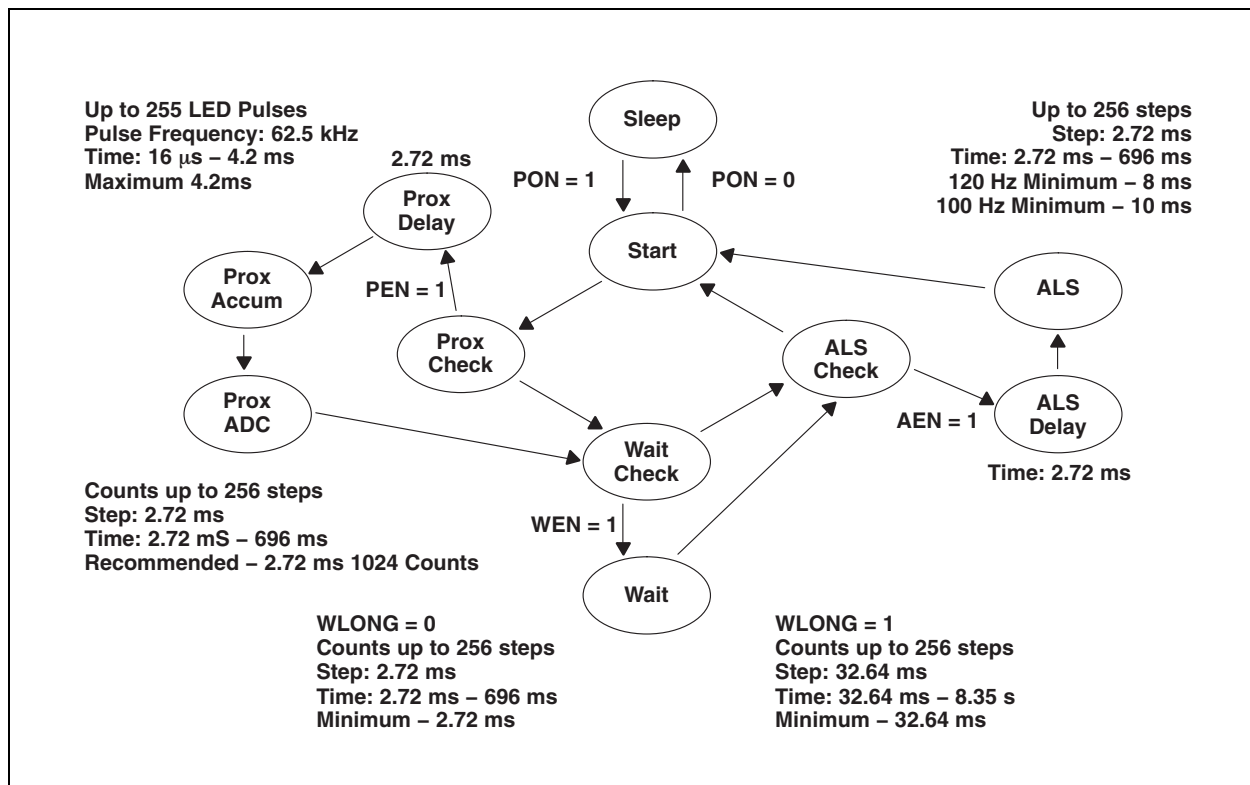

### Power Management

Power consumption can be controlled through the use of the wait state timing because the wait state consumes only 65  $\mu\text{A}$  of power. Figure 25 shows an example of using the power management feature to achieve an average power consumption of 155  $\mu\text{A}$  current with four 100-mA pulses of proximity detection and 50 ms of ALS detection.

Figure 25:  
Power Consumption Calculations

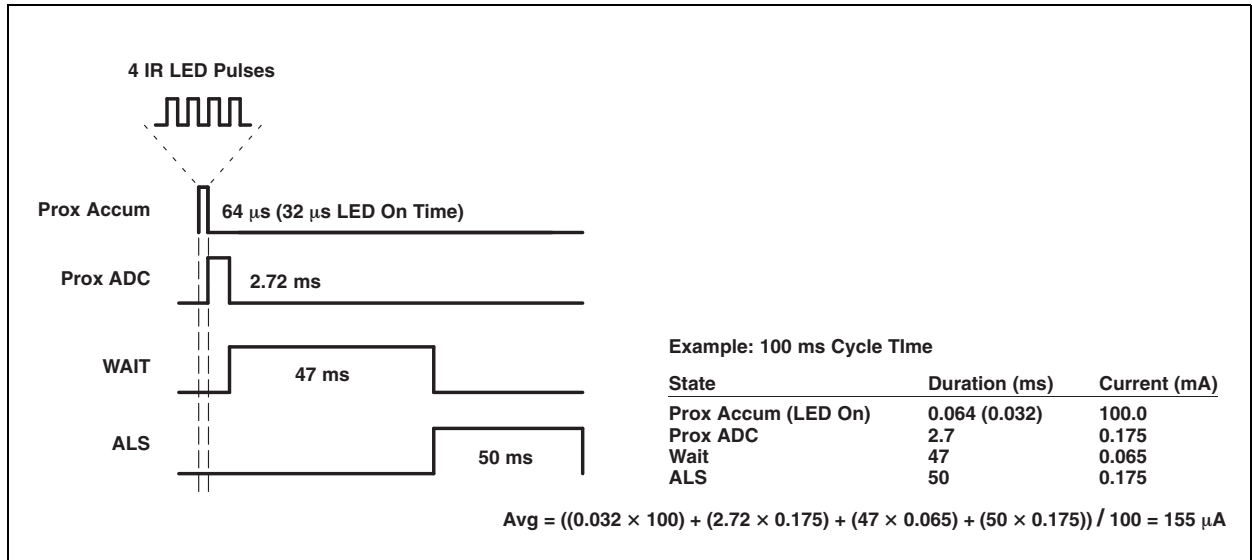

## I<sup>2</sup>C Protocol

Interface and control are accomplished through an I<sup>2</sup>C serial compatible interface (standard or fast mode) to a set of registers that provide access to device control functions and output data. The devices support the 7-bit I<sup>2</sup>C addressing protocol.

The I<sup>2</sup>C standard provides for three types of bus transaction: read, write, and a combined protocol (Figure 26). During a write operation, the first byte written is a command byte followed by data. In a combined protocol, the first byte written is the command byte followed by reading a series of bytes. If a read command is issued, the register address from the previous command will be used for data access. Likewise, if the MSB of the command is not set, the device will write a series of bytes at the address stored in the last valid command with a register address. The command byte contains either control information or a 5-bit register address. The control commands can also be used to clear interrupts.

The I<sup>2</sup>C bus protocol was developed by Philips (now NXP). For a complete description of the I<sup>2</sup>C protocol, please review the NXP I<sup>2</sup>C design specification at <http://www.i2c-bus.org/references/>.



A	Acknowledge (0)
N	Not Acknowledged (1)
P	Stop Condition
R	Read (1)
S	Start Condition
S	Repeated Start Condition
W	Write (0)
...	Continuation of protocol
	Master-to-Slave
	Slave-to-Master

Figure 26:  
I<sup>2</sup>C Protocols



## Register Set

The TSL2771 is controlled and monitored by data registers and a command register accessed through the serial interface.

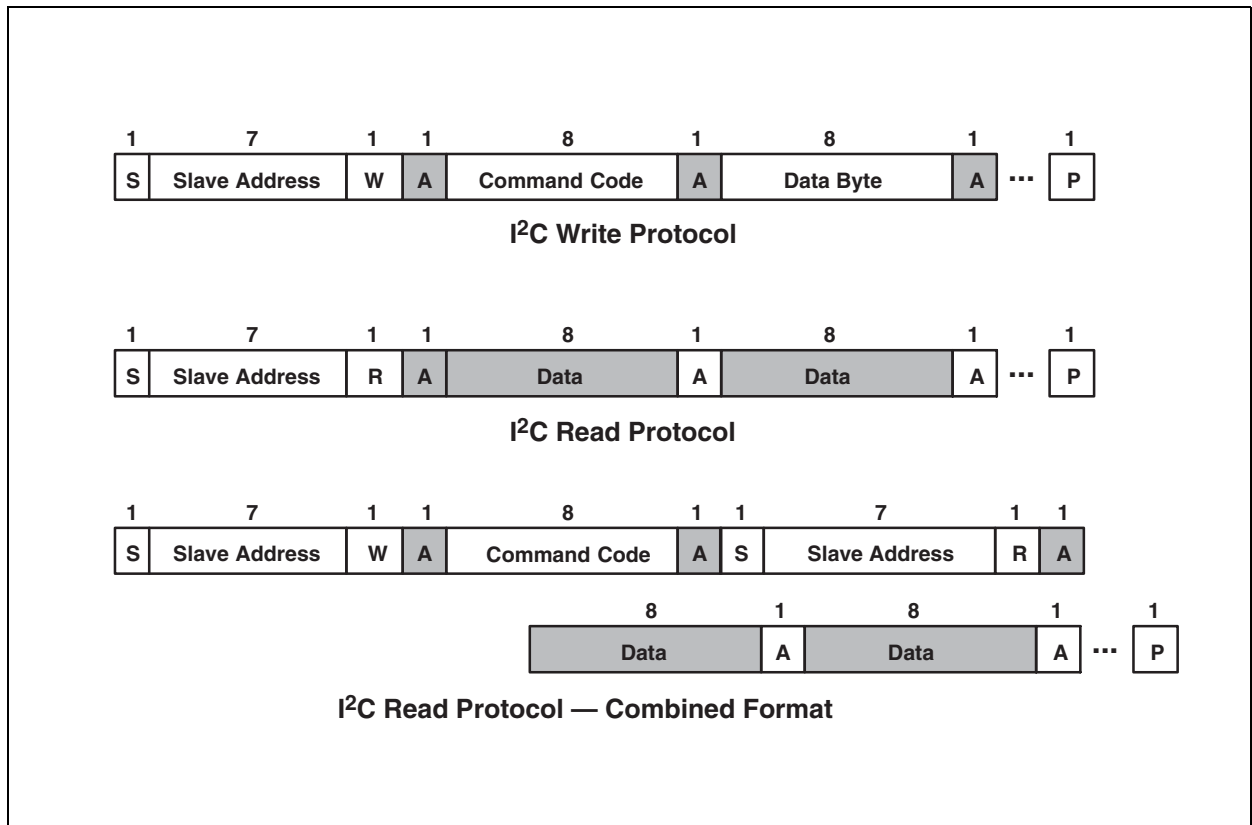
These registers provide for a variety of control functions and can be read to determine results of the ADC conversions. The register set is summarized in [Figure 27](#).

**Figure 27:**  
Register Address

Address	Register Name	R/W	Register Function	Reset Value
--	COMMAND	W	Specifies register address	0x00
0x00	ENABLE	R/W	Enables states and interrupts	0x00
0x01	ATIME	R/W	ALS ADC time	0xFF
0x02	PTIME	R/W	Proximity ADC time	0xFF
0x03	WTIME	R/W	Wait time	0xFF
0x04	AILTL	R/W	ALS interrupt low threshold low byte	0x00
0x05	AILTH	R/W	ALS interrupt low threshold high byte	0x00
0x06	AIHTL	R/W	ALS interrupt high threshold low byte	0x00
0x07	AIHTH	R/W	ALS interrupt high threshold high byte	0x00
0x08	PILTL	R/W	Proximity interrupt low threshold low byte	0x00
0x09	PILTH	R/W	Proximity interrupt low threshold high byte	0x00
0x0A	PIHTL	R/W	Proximity interrupt high threshold low byte	0x00
0x0B	PIHTH	R/W	Proximity interrupt high threshold high byte	0x00
0x0C	PERS	R/W	Interrupt persistence filters	0x00
0x0D	CONFIG	R/W	Configuration	0x00
0x0E	PPCOUNT	R/W	Proximity pulse count	0x00
0x0F	CONTROL	R/W	Control register	0x00
0x12	ID	R	Device ID	ID
0x13	STATUS	R	Device status	0x00
0x14	C0DATA	R	CH0 ADC low data register	0x00
0x15	C0DATAH	R	CH0 ADC high data register	0x00
0x16	C1DATA	R	CH1 ADC low data register	0x00
0x17	C1DATAH	R	CH1 ADC high data register	0x00