



Chipsmall Limited consists of a professional team with an average of over 10 year of expertise in the distribution of electronic components. Based in Hongkong, we have already established firm and mutual-benefit business relationships with customers from,Europe,America and south Asia,supplying obsolete and hard-to-find components to meet their specific needs.

With the principle of “Quality Parts,Customers Priority,Honest Operation,and Considerate Service”,our business mainly focus on the distribution of electronic components. Line cards we deal with include Microchip,ALPS,ROHM,Xilinx,Pulse,ON,Everlight and Freescale. Main products comprise IC,Modules,Potentiometer,IC Socket,Relay,Connector.Our parts cover such applications as commercial,industrial, and automotives areas.

We are looking forward to setting up business relationship with you and hope to provide you with the best service and solution. Let us make a better world for our industry!



## Contact us

Tel: +86-755-8981 8866 Fax: +86-755-8427 6832

Email & Skype: info@chipsmall.com Web: www.chipsmall.com

Address: A1208, Overseas Decoration Building, #122 Zhenhua RD., Futian, Shenzhen, China



DO NOT SCALE FROM THIS PRINT

TSM-1XX-XX-XXX-SV-XX-XXX-XX

No. OF POSITIONS  
-02 THRU -50

LEAD STYLE  
SEE TABLE 1

PLATING SPECIFICATION

- T: MATT TIN CONTACT AND TAIL
- S: SELECTIVE, 30 Au / 50 Ni MIN ON CONTACT, MATTE TIN TAIL
- G: GOLD, 10 Au / 50 Ni MIN ON CONTACT, 3 Au / 50 Ni MIN ON TAIL
- L: LIGHT SELECTIVE, 10 Au / 50 Ni MIN ON CONTACT, MATTE TIN ON TAIL
- F: FLASH SELECTIVE, 3 Au / 50 Ni MIN ON CONTACT, MATTE TIN TAIL
- H: HEAVY GOLD, 30 Au / 50 Ni MIN ON CONTACT, 3 Au / 50 Ni MIN ON TAIL
- TL: TIN / LEAD (90/10+/-5%) CONTACT AND TAIL [LEAD STYLE -01 & -02 ONLY]
- STL: SELECTIVE, 30 Au / 50 Ni MIN ON CONTACT, TIN/LEAD (90/10+/-5%) TAIL [LEAD STYLE -01 & -02 ONLY]
- TM: MATTE TIN CONTACT AND TAIL
- SM: SELECTIVE, 30 Au / 50 Ni MIN ON CONTACT, MATTE TIN TAIL
- LM: LIGHT SELECTIVE, 10 Au / 50 Ni MIN ON CONTACT, MATTE TIN TAIL
- FM: FLASH SELECTIVE, 3 Au / 50 Ni MIN ON CONTACT, MATTE TIN TAIL
- SS: STRIPE SELECTIVE, 30 Au / 50 Ni MIN ON CONTACT, MATTE TIN TAIL (SEE NOTE 9)

OPTION #3

- P: PICK & PLACE PAD (SEE FIG. 3) [USE PPP-07] (4 POS MINIMUM OR -02 & -03 POS WITH -TR) (SEE NOTE 7)
- TR: TAPE & REEL (SEE NOTE 7) (-02 THRU -22 POS)

OPTION #2

POLARIZED POSITION: SPECIFY PIN OMITTED

OPTION #1

- LC: LOCKING CLIP (SEE FIG. 1) (SEE NOTE 8) [USE LC-08-TM-02] (-03 THRU -36 POS: 2 PER STRIP, -02 POS: 1 PER STRIP)
- A: ALIGNMENT PIN (SEE FIG. 2)

ROW SPECIFICATION

-SV: SINGLE VERTICAL (USE TSM-XX-SV-XX)

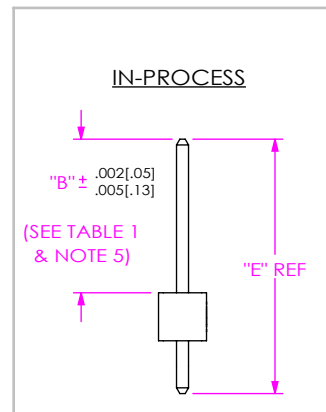
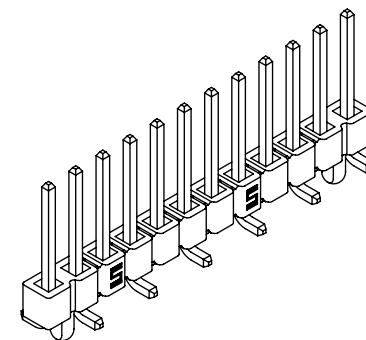
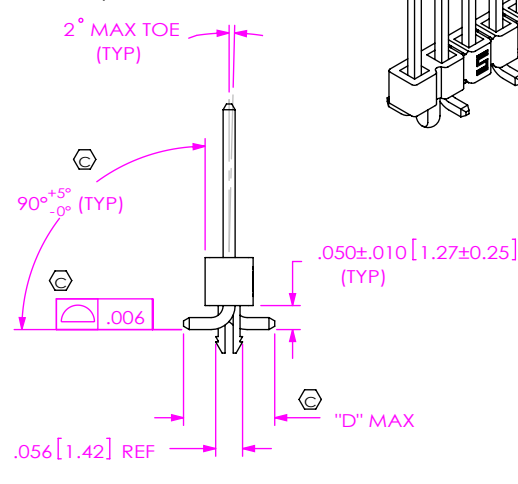
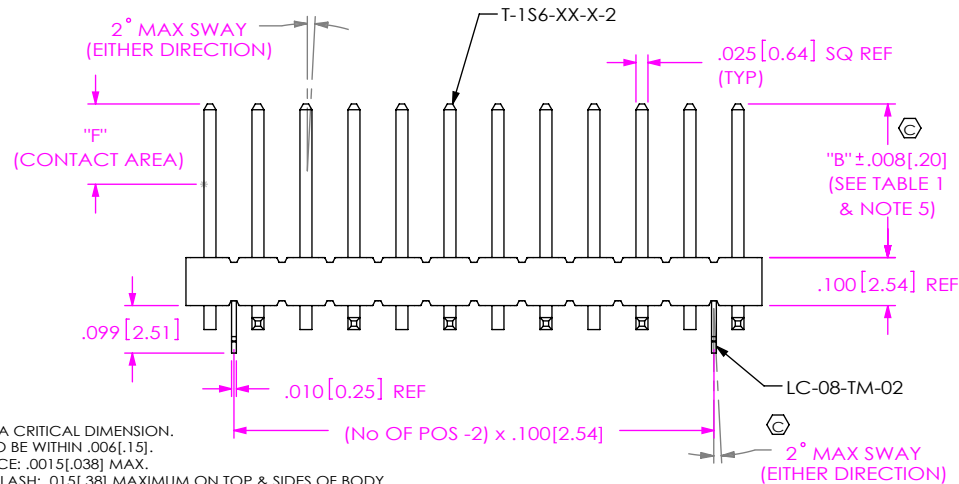
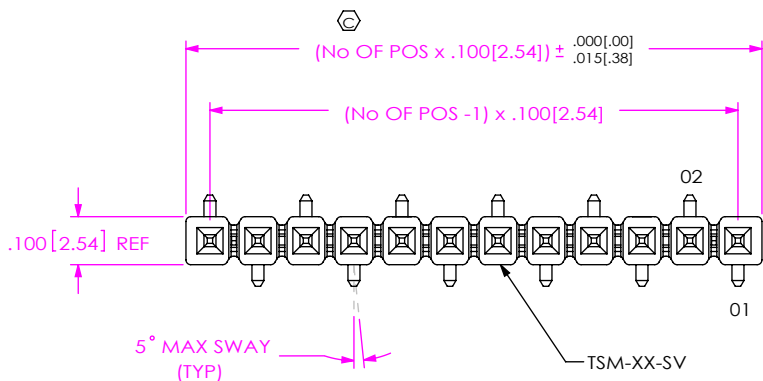

NOTES:

1.  $\text{⊕}$  REPRESENTS A CRITICAL DIMENSION.
2. COPLANARITY TO BE WITHIN .006[.15].
3. BURR ALLOWANCE: .0015[.038] MAX.
4. MAXIMUM CUT FLASH: .015[.38] MAXIMUM ON TOP & SIDES OF BODY AND .030[.76] MAXIMUM ON SURFACE MOUNT SIDE OF BODY.
5. POST HEIGHT VARIATION BETWEEN ANY TWO PINS: .005[.13] MAXIMUM.
6. MAXIMUM ALLOWABLE BOW: .002[.05] INCH/INCH AFTER ASSEMBLY.
7. LEADS MAY NOT BE VISIBLE FOR CUSTOMER VISUAL INSPECTION WITH -P OPTION ON SMALLER POSITIONS PARTS.
8. DUE TO THE HIGH AMOUNT OF INSERTION FORCE NEEDED, THE -LC OPTION IS NOT COMPATIBLE WITH AUTO PLACEMENT. SAMTEC RECOMMENDS MANUAL PLACEMENT FOR ALL ASSEMBLIES WITH THE -LC OPTION.
9. -01 LEAD STYLE ONLY, MATES WITH SSW, SSQ, BCS, SSM, ESW, ESQ.
10. MINIMUM PUSHOUT FORCE: 2LB. [8.90 N]

TABLE 1

STYLE	"B"	"C"	"D" MAX	"E"	"F"	TERMINAL
-01	.230[5.84]	.280[7.11]	.208[5.28]	.445[11.30]	.165 [4.19]	T-1S6-16-X-2
-02	.320[8.13]	.370[9.40]	.205[5.20]	.530[13.46]	.165 [4.19]	T-1S6-08-X-2
-03	.420[10.67]	.470[11.94]	.205[5.20]	.630[16.00]	.165 [4.19]	T-1S6-15-X-2
-04	.120[3.05]	.270[6.86]	.208[5.28]	.335[8.51]	.050 [1.27]	T-1S6-21-X-2
-05	.075[1.91]	.270[6.86]	.223[5.66]	.300[7.62]	.050 [1.27]	T-1S6-18-X-2

FIG 1

TSM-112-02-XXX-SV-LC SHOWN

UNLESS OTHERWISE SPECIFIED, DIMENSIONS ARE IN INCHES.

TOLERANCES ARE:

DECIMALS ANGLES  
 .XX: ±.01 [.3] 2°  
 .XXX: ±.005 [.13]  
 .XXXX: ±.0020 [.051]

PROPRIETARY NOTE

THIS DOCUMENT CONTAINS CONFIDENTIAL AND PROPRIETARY INFORMATION AND ALL DESIGN, MANUFACTURING, REPRODUCTION, USE, PATENT RIGHTS AND SALES RIGHTS ARE EXPRESSLY RESERVED BY SAMTEC, INC. THIS DOCUMENT SHALL NOT BE DISCLOSED, IN WHOLE OR PART, TO ANY UNAUTHORIZED PERSON OR ENTITY NOR REPRODUCED, TRANSFERRED OR INCORPORATED IN ANY OTHER PROJECT IN ANY MANNER WITHOUT THE EXPRESS WRITTEN CONSENT OF SAMTEC, INC.

MATERIAL: DO NOT SCALE DRAWING

INSULATOR:  
LCP, UL 94 VO  
COLOR: BLACK

TERMINAL: PHOS BRONZE

F:\DWG\MISC\MKTG\TSM-1XX-XX-XXX-SV-XX-XXX-MKT.SLDDRW

SHEET SCALE: 2.5:1



520 PARK EAST BLVD, NEW ALBANY, IN 47150  
 PHONE: 812-944-6733 FAX: 812-948-5047  
 e-Mail info@SAMTEC.com code 53322

DESCRIPTION:

SINGLE ROW .100 SMT ASSEMBLY

DWG. NO.

TSM-1XX-XX-XXX-SV-XX-XXX-XX

BY: DEAN P

8/21/2002

SHEET 1 OF 2

FIG 3

-P: PICK & PLACE PAD OPTION  
4 POSITION MINIMUM  
[PLACE PAD ON CENTERLINE AS SHOWN]

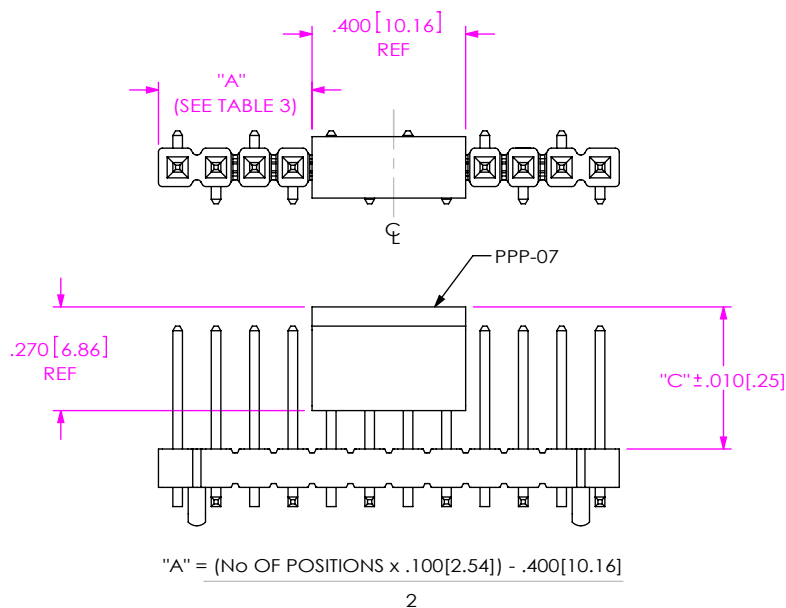

POSITION	TOLERANCE
-02 THRU -04	"A" +/- .010
-05 THRU -50	"A" +/- .020

FIG 2

-A: ALIGNMENT PIN OPTION  
TSM-112-02-X-SV-A SHOWN  
[DIFFERENT AS SHOWN, OTHERWISE SAME AS FIG 1]

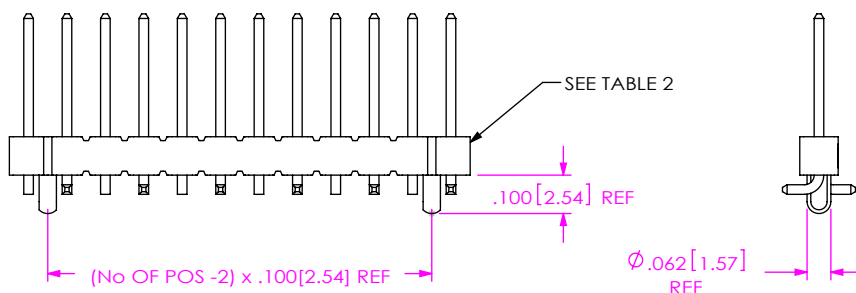

POSITION	USE BODY
-3	TSM-03-SV-A
-02 & -04 THRU -50	TSM-XX-SV-X

PACKAGING TABLE

STYLE	OPTION	TUBE	PLUG
-01	----	PT-1-24-02-29 (SEE NOTE 3)	TP-24
-02, -04, -05	----	PT-1-24-02-29 (SEE NOTE 3)	TP-24
-01, -02, -04, -05	-LC, -A	PT-1-24-02-29 (SEE NOTE 3)	TP-24
-01, -04, -05	-P	PT-1-24-05-29	TP-03
-01, -04, -05	-LC-P, -A-P	PT-1-24-05-29	TP-03
-02	-P	PT-1-24-13-29	TP-03
-02	-LC-P, -A-P	PT-1-24-13-29	TP-03
-03	----	PT-1-24-10-29 (SEE NOTE 3)	TP-24
-03	-LC, -A	PT-1-24-10-29 (SEE NOTE 3)	TP-24
-03	-P	PT-1-24-14-29	TP-09
-03	-LC-P, -A-P	PT-1-24-14-29	TP-09

NOTES:

1. LOAD PARTS POSITION 1 FIRST IN SAME DIRECTION AS ARROW.
2. NOTE DELETED
3. PACKAGE POSITIONS -04 THRU -36.
4. POLARIZED 4 POSITION PARTS WITHOUT PADS ARE TO BE LAYER PACKAGED OR PACKAGED IN TAPE AND REEL.

FIG 4

TUBE PACKAGING

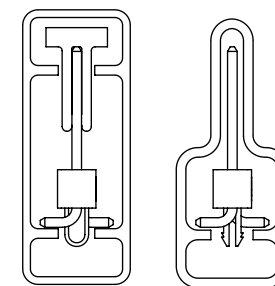
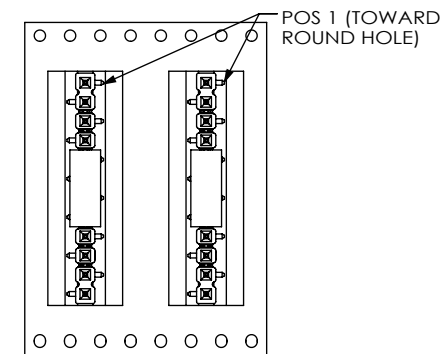
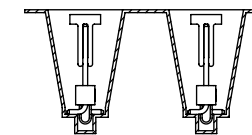

FIG 5

-TR: TAPE & REEL PACKAGING OPTION



USER DIRECTION OF UN-REELING  
POCKET NOT DETAILED



F:\DWG\MISC\MKTG\TSM-1XX-XX-XXX-SV-XX-XXX-XX-MKT.SLDDRW

PROPRIETARY NOTE

THIS DOCUMENT CONTAINS CONFIDENTIAL AND PROPRIETARY INFORMATION AND ALL DESIGN, MANUFACTURING, REPRODUCTION, USE, PATENT RIGHTS AND SALES RIGHTS ARE EXPRESSLY RESERVED BY SAMTEC, INC. THIS DOCUMENT SHALL NOT BE DISCLOSED, IN WHOLE OR PART, TO ANY UNAUTHORIZED PERSON OR ENTITY NOR REPRODUCED, TRANSFERRED OR INCORPORATED IN ANY OTHER PROJECT IN ANY MANNER WITHOUT THE EXPRESS WRITTEN CONSENT OF SAMTEC, INC.



520 PARK EAST BLVD, NEW ALBANY, IN 47150  
PHONE: 812-944-6733 FAX: 812-948-5047  
e-Mail: info@SAMTEC.com code 55322

DO NOT SCALE DRAWING

SHEET SCALE: 2:1

DESCRIPTION:  
SINGLE ROW .100 SMT ASSEMBLY  
DWG. NO.  
TSM-1XX-XX-XXX-SV-XX-XXX-XX  
BY: DEAN P 8/21/2002 SHEET 2 OF 2