



Chipsmall Limited consists of a professional team with an average of over 10 year of expertise in the distribution of electronic components. Based in Hongkong, we have already established firm and mutual-benefit business relationships with customers from,Europe,America and south Asia,supplying obsolete and hard-to-find components to meet their specific needs.

With the principle of “Quality Parts,Customers Priority,Honest Operation,and Considerate Service”,our business mainly focus on the distribution of electronic components. Line cards we deal with include Microchip,ALPS,ROHM,Xilinx,Pulse,ON,Everlight and Freescale. Main products comprise IC,Modules,Potentiometer,IC Socket,Relay,Connector.Our parts cover such applications as commercial,industrial, and automotives areas.

We are looking forward to setting up business relationship with you and hope to provide you with the best service and solution. Let us make a better world for our industry!



Contact us

Tel: +86-755-8981 8866 Fax: +86-755-8427 6832

Email & Skype: info@chipsmall.com Web: www.chipsmall.com

Address: A1208, Overseas Decoration Building, #122 Zhenhua RD., Futian, Shenzhen, China



Primary PWM Controller

- **Current-mode PWM Controller**
- **Internal Under Voltage Protection**
- **Programmable Under Voltage**
- **High-current Output Drive Suitable for Power Mosfet**
- **Programmable Soft Start**
- **2kV ESD Protection**

DESCRIPTION

The TSM007 integrated circuit incorporates all circuitry to implement off line or DC-DC power supply applications using a fixed frequency current mode control.

Based on a standard current mode PWM controller, this device includes additional features for higher integration.

APPLICATION

- **PC SMPS**

ORDER CODE

Part Number	Temperature Range	Package	Packaging
TSM007IN	0, +95°C	DIP	Tube
TSM007ID		SO	Tube
TSM007IDT		SO	Tape & Reel

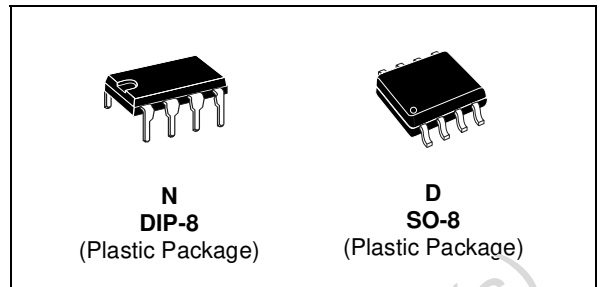

PIN CONNECTIONS (top view)

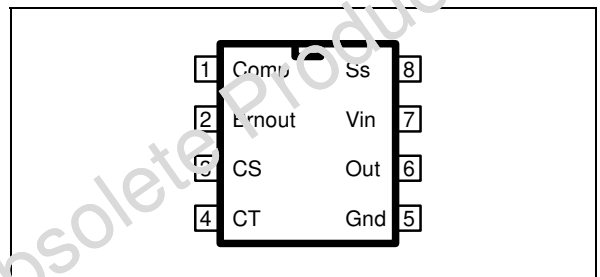

1 Block Diagram

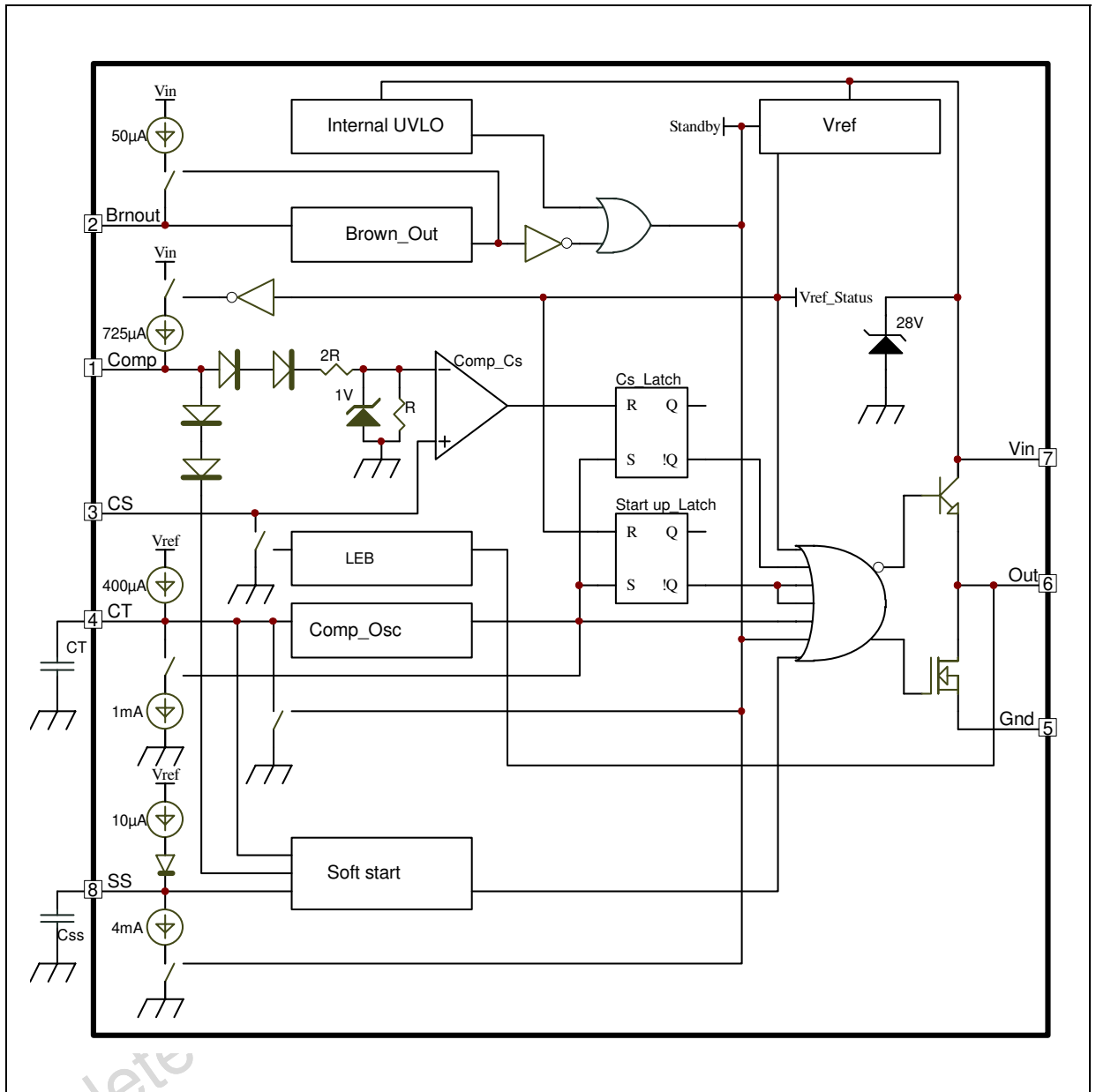

PIN DESCRIPTION

Name	Pin	Type	Function
COMP	1	Analog input	Current comparator for current mode control.
BRNOUT	2	Analog input	Undervoltage.
CS	3	Analog input	Current sense.
CT	4	Timing capacitor	Sets the oscillator frequency.
GND	5	Power supply	Signal ground.
OUT	6	Analog output	Totem pole output to direct drive a power MOSFET.
VIN	7	Power supply	Supply input voltage.
SS	8	Timing capacitor	Soft start.

2 Absolute Maximum Ratings

Symbol	DC Supply Voltage	Value	Unit
V _{in}	DC Supply Voltage ¹	-0.3 to 25	V
I _o	DC output current	0.1	A
I _{opeak}	Peak output current	1	A
V _{comp}	COMP terminal voltage	-0.3 to 5.5	V
I _{sinkcomp}	COMP terminal sink current	6	mA
V _{Brnout}	Brown out terminal voltage	-0.3 to V _{in}	V
V _{cs}	CS terminal voltage	-0.3 to 6.3	V
V _{ct}	CT terminal voltage	-0.3 to 5.0	V
V _{out}	OUT terminal voltage	-0.3 to V _{in}	V
V _{ss}	SS terminal voltage	-0.3 to 6.4	V
P _t	Power dissipation at 25°C	500	mW
T _{stg}	Storage temperature	-40 to 150	°C
T _j	Junction temperature	150	°C
ESD	Electrostatic Discharge	2	kV

1) All voltage values, except differential voltage are with respect to network ground terminal (GND).

OPERATING CONDITIONS

Symbol	Parameter	Value	Unit
V _{cc}	DC Supply Conditions	12 to 25	V
T _{oper}	Operating Free Air Temperature Range	0 to 95	°C

3 Electrical Characteristics

Tamb = 25°C, Vin=12V, Ct=1.5nF unless otherwise specified

Symbol	Parameter	Test Condition	Min	Typ	Max	Unit
Oscillator						
Fosc	Oscillating frequency		84	100	116	kHz
Foscmax	Maximum oscillating frequency		500			kHz
Δfosc1	Typical oscillating voltage stability	12V ≤ Vin ≤ 25V		±0.5	±2.0	%
Δfosc2	Typical oscillating temperature stability	0°C ≤ Ta ≤ 70°C		±10		%
Ici	Charge current	Vct=2V	336	400	464	μA
Icd	Discharge current	Vct=2V	504	600	696	μA
Vthct	Upper trip point			3.0		V
Vtlct	Lower trip point			1.4		V
ΔVct	Amplitude			1.6		V
Brown out						
Vbr	Threshold voltage		2.42	2.50	2.58	V
Ibr-on	Brown out terminal source current	Vbr=3V, 0°C ≤ T ≤ 70°C	42	50	58	μA
Vbrin	Input voltage		-0.3		Vin	V
Comp						
Icomp	Source current	Vcomp=5V	0.5	0.725	0.950	μA
Current sense						
Avcs	Gain	0V ≤ Vcs ≤ 0.8V	2.85	3.00	3.15	
Vthcs	Maximum sensing voltage	Vcomp=5V	0.9	1.0	1.1	V
PSRR	Power supply voltage rejection ratio	12V ≤ Vin ≤ 25V		70		dB
Ibcs	Input bias current	Vcs=2V		0.5	10	μA
Leading edge blanking						
LEB	Delay to output	Vcs = 0 to 1 V Vcomp = 2 V		280		ns
Output						
VOL1	Output low voltage 1	Iosink=20mA		0.1	1.5	V
VOL2	Output low voltage 2	Iosink=200mA		0.8	2.2	V
VOH1	Output high voltage 1	Iosource=20mA	Vin-2.0	Vin-1.5		V
VOH2	Output high voltage 2	Iosource=200mA	Vin-3.0	Vin-1.7		V
tr	Rise time	CL=1nF, 10% to 90%		100	150	ns
tf	Fall time	CL=1nF, 90% to 10%		30	60	ns
VOL3	UVLO saturation	Vin=5V, Iosink=1mA		0.05	1.1	V
Dmax	Maximum duty cycle		54	60	66	%
Soft start						
Iiss	Source current	Vss=2V	8	10	12	μA
dIiss	Temperature stability	0°C ≤ Ta ≤ 70°C	7	10	13	μA
Icss	Sink current	Vss=2V, Vbr=2V	4			mA
VHss	Clamp voltage		4.2			V
VLss	Low voltage	Vbr=2V			0.2	V
Internal Under Voltage Lockout (UVLO)						
VH	UVLO top threshold		8.9	9.5	10.1	V
VL	UVLO bottom threshold		7.3	7.9	8.5	V
dVuvlo	UVLO hysteresis voltage	dVuvlo=VH-VL		1.6		V
Total current consumption						
Iin	Operating current	CL=3.3nF, Vin=12V		10	13	mA
Istby	Supply current in standby mode	Vbr ≤ 1V, Vin=12V		250	350	μA

4 Functional Description

TSM007: PWM Controller IC

Internal UVLO function

The Under Voltage Lock Out function disables the whole device when supply voltage is lower than the threshold.

Vref block

The Vref block provides an internal 5V reference voltage to the IC. An internal Vref status signal is active when Vref is lower than 4.7V and is used to drive the output driver low when Vref is not valid.

Startup latch

The startup latch is set when the IC exits from standby mode or UVLO state. It is reset when the CT capacitor is discharged for the first time.

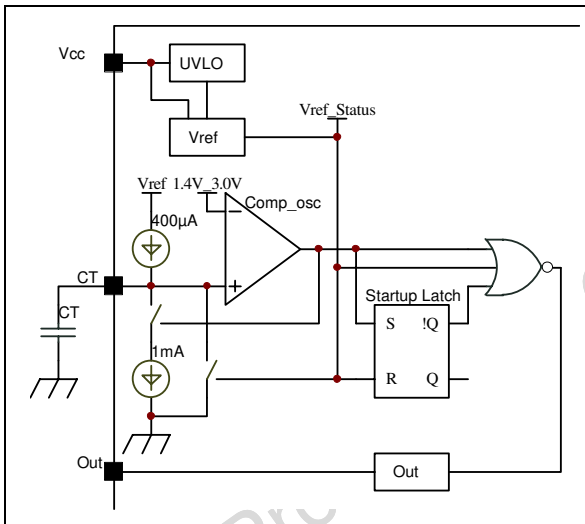

Current sense input

A voltage proportional to the transformer primary winding current is applied to the CS pin. The control IC uses this information to perform current mode control. The PWM function will be stopped if the CS pin voltage is greater than 1.0V.

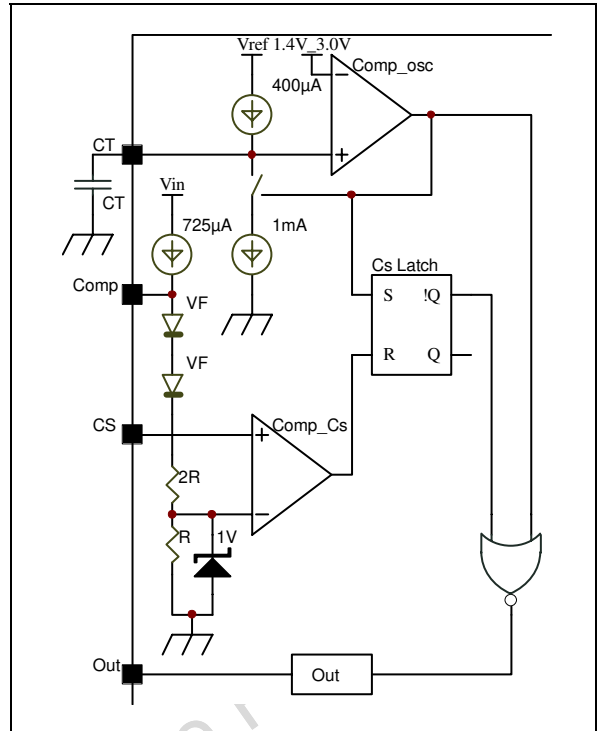

Oscillator

A capacitor from the CT pin to GND sets the oscillating frequency.

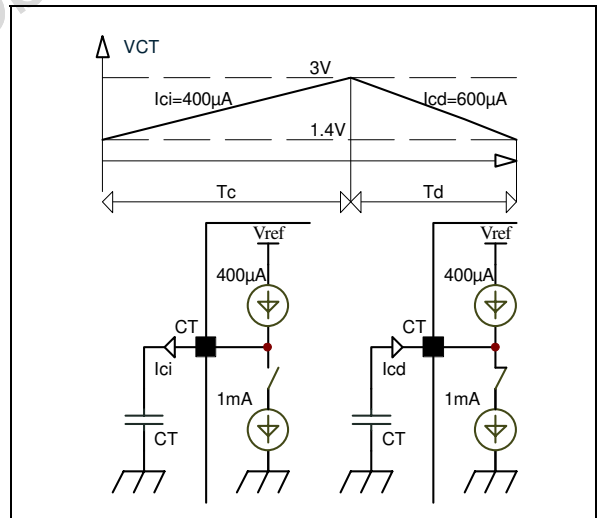

$$T = T_c + T_d$$

$$T = CT \Delta V_{ct} / I_{ci} + CT \Delta V_{ct} / I_{cd}$$

Let's assume $F = 1/T = 100\text{KHz}$

$$\implies CT = (I_{ci} I_{cd}) / (F \Delta V_{ct} (I_{ci} + I_{cd}))$$

$$\implies CT = 1.5\text{nF}$$

Soft start

A capacitor from the SS pin to GND provides the soft start function. The capacitor starts to charge when VIN reaches the UVLO threshold and Vref is good. The soft start block enables the IC to start with a progressive PWM duty cycle. The soft start period is set by the external capacitor C_{SS}. The soft start comparator drives the output driver low when the SS pin voltage is greater than the CT pin voltage minus one V_F voltage..

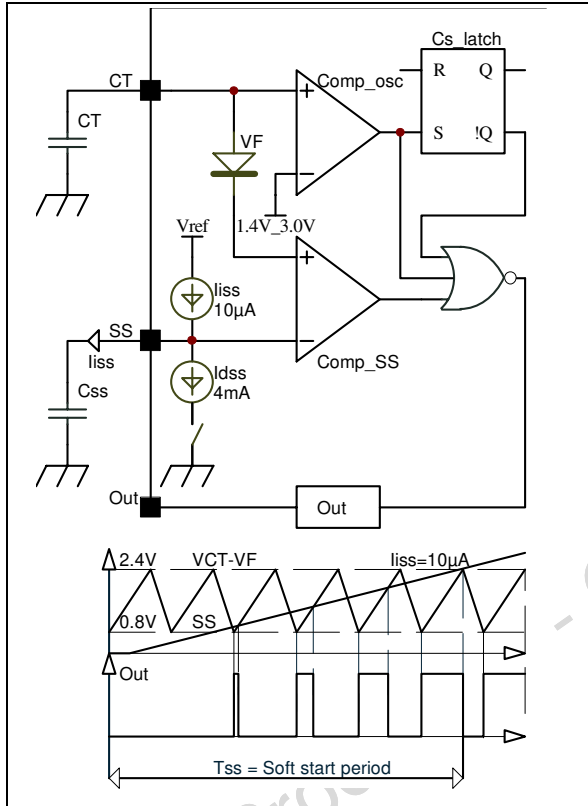

$$T_{SS} = C_{SS} \times (V_{thct} - V_F) / I_{SS}$$

Let's assume T_{SS} = 50ms

$$\implies C_{SS} = T_{SS} \times I_{SS} / (V_{thct} - V_F)$$

$$\implies C_{SS} = 210\text{nF}$$

Brown out

A voltage proportional to the Bulk capacitor voltage is applied to the BRNOUT pin. When this pin signal is less than 2.5V, the IC is disabled: SS and CT pins go low, V_{ref} is disabled and the IC goes to standby mode. All bias currents are switched off. The 2.5V voltage at the negative input of comparator Comp_Brown out is still active. When Brown out voltage goes higher than 2.5V, V_{ref} is enabled again. A startup period is started, and then a soft start occurs..

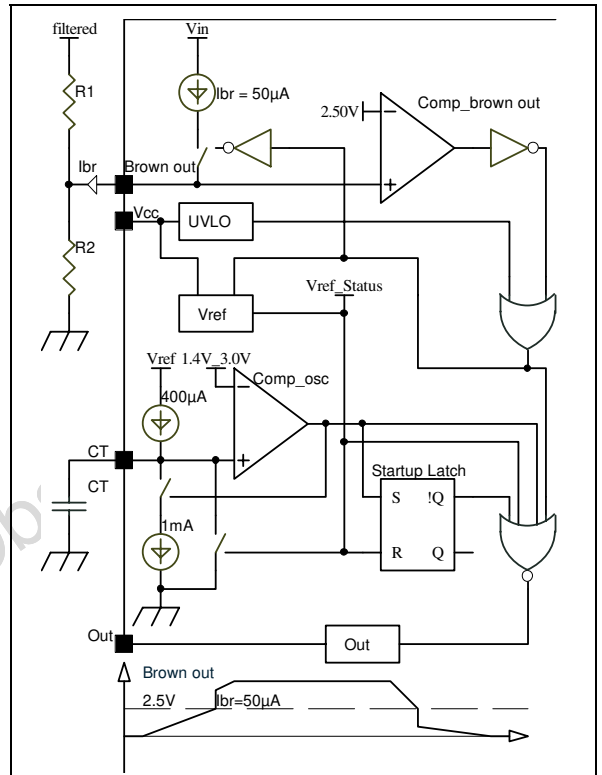

Let's assume BRNOUT acts for V_{filtered} = 200V

$$R_2 = 15\text{K}\Omega$$

$$R_1 = R_2 \times (V_{filtered} - UVLO) / UVLO$$

When BRNOUT is below 2.5V

$$I_{R2} = V_{filtered} \times (R_1 + R_2)$$

When BRNOUT is above 2.5V

$$I_{R2} = I_{BR} + V_{filtered} \times (R_1 + R_2)$$

$$BRNOUT = R_2 \times (I_{BR} + V_{filtered} \times (R_1 + R_2))$$

$$R_1 = 1185\text{K}\Omega$$

$$R_2 = 167\mu\text{A}$$

When BRNOUT is above 2.5V

$$I_{R2} = 237\mu\text{A}$$

$$BRNOUT = 3.55\text{V}$$

COMP input

This pin is connected to the current comparator for current mode control. The pin should be connected to the collector (primary side) of an optocoupler which anode (secondary side) is driven by the output of error amplifier.

The COMP input is used to set the reference level for the current sense comparator. The current sense threshold is set to $(V_{comp} - 2 * V_{be}) / 3$.

Standby consumption

The low current value supply in stand by mode reduces the consumption ..

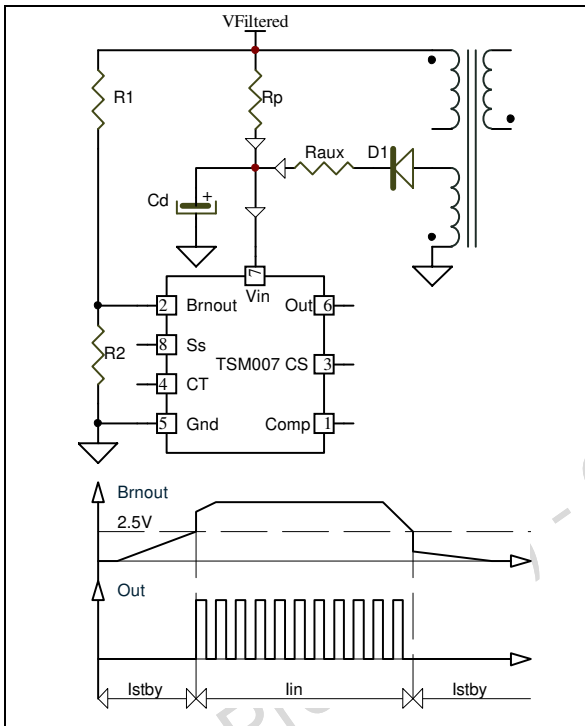

When Brnout is below 2.5V, Vfiltered below 200V the PWM is off.

==> $I_{cc} = I_{stby}$.

$$R_p \approx (V_{filtered} - V_z) / I_{stby}$$

In normal mode, the Vfiltered voltage can go up to 400V.

$$\text{==> } R_{pmax} \text{ dissipation} = (V_{filtered} - V_{in})^2 / R_p$$

The lin current is provided by the auxiliary winding.

Let's assume $V_{filtered} = 200V$

$$R_p = 620K\Omega$$

$$R_{pmax} \text{ dissipation} = 220mW$$

Output driver

The OUT totem pole output is capable to sink and source more than 1.0A (peak) in order to direct drive a power MOSFET..

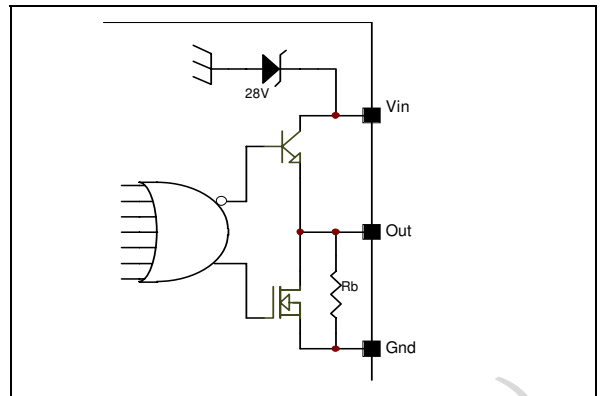
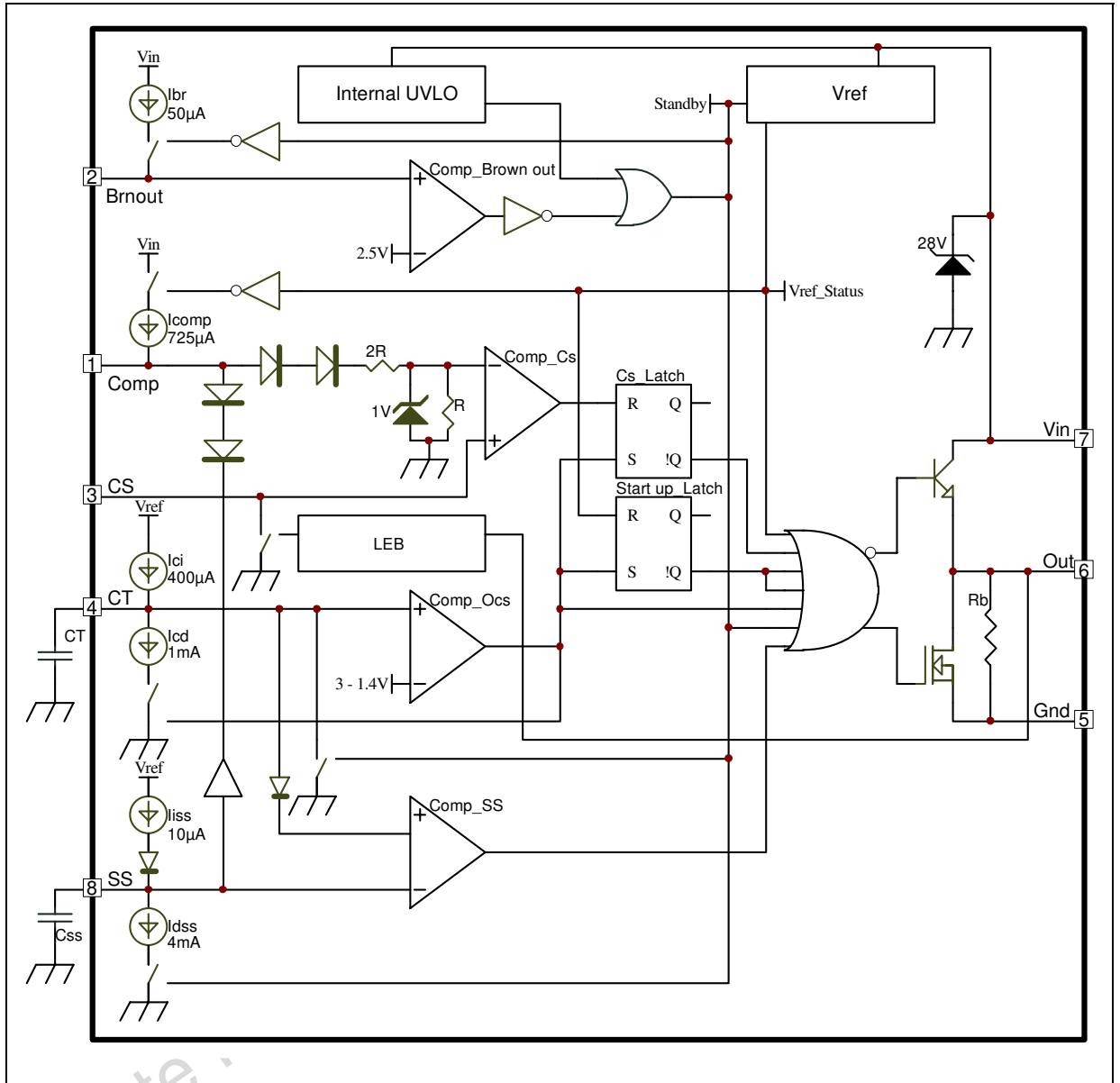
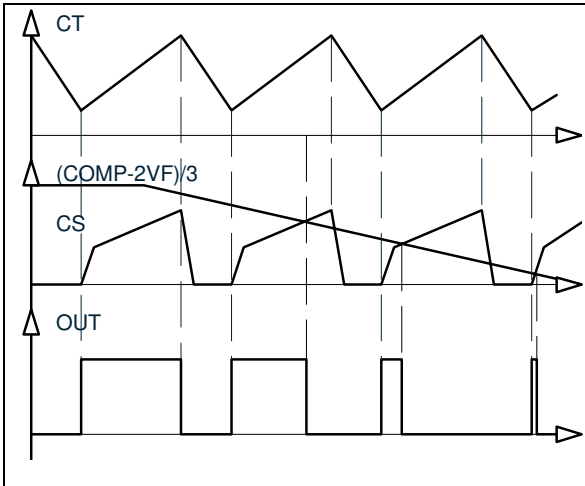

Fig. 1: Detailed Internal Schematic



Timing for PWM function



Timing for Soft Start function

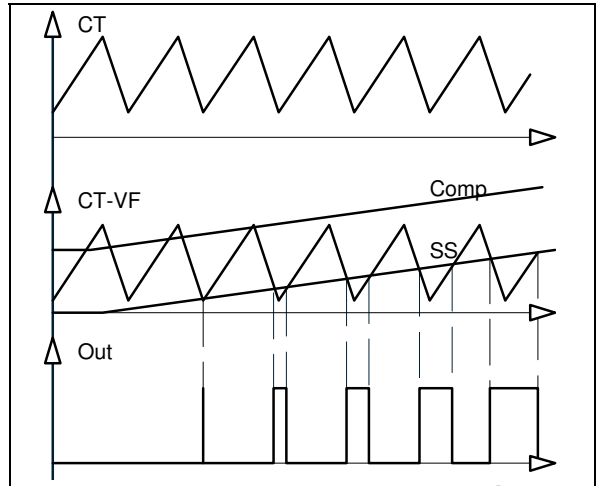

Timing at Vref rise up and shut down

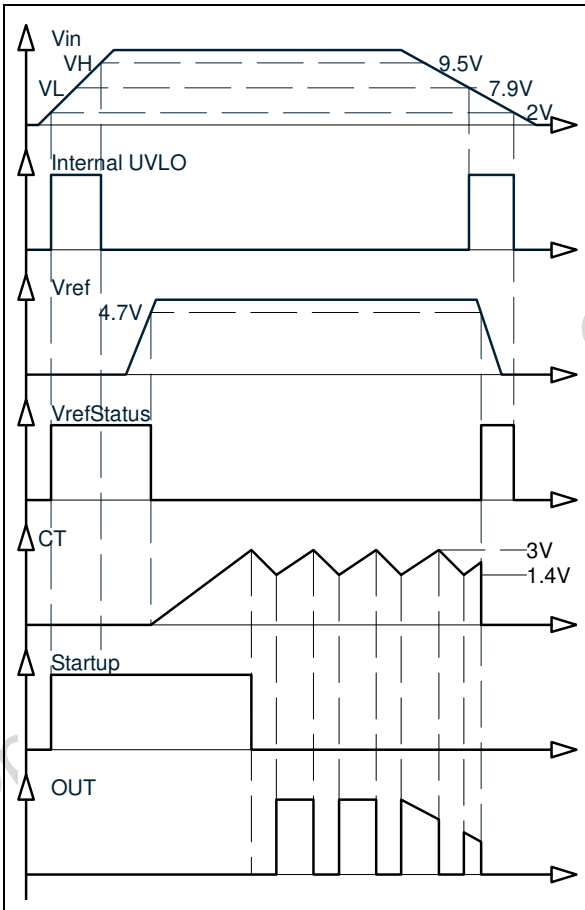

Timing at UVLO rise up and shut down

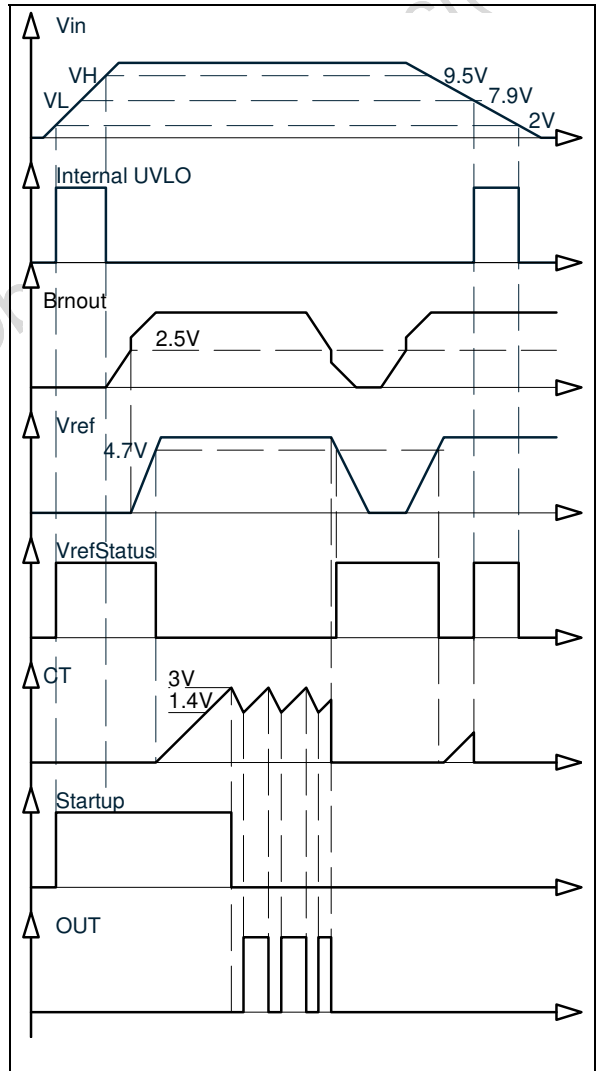
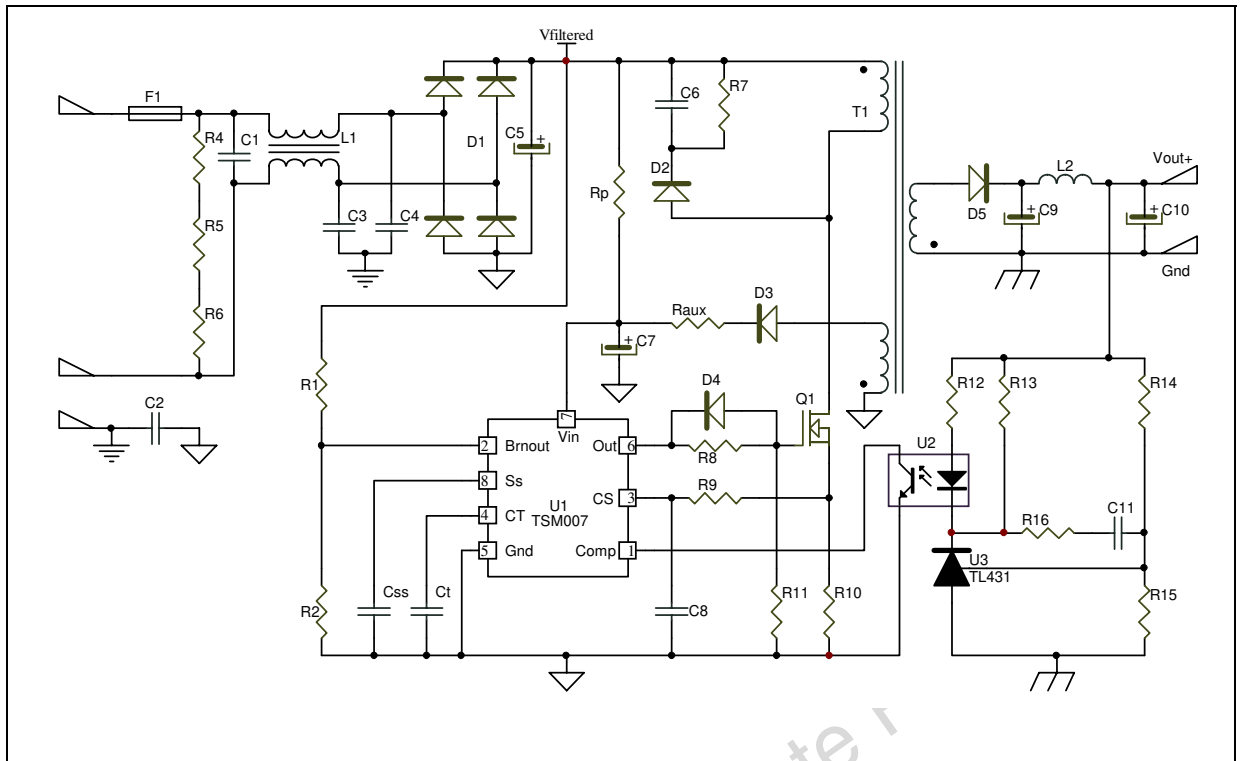

Fig. 2: Application schematic



5 Package Mechanical Data

Plastic DIP-8 MECHANICAL DATA

DIM.	mm.			inch		
	MIN.	TYP.	MAX.	MIN.	TYP.	MAX.
A		3.3			0.130	
a1	0.7			0.028		
B	1.39		1.65	0.055		0.065
B1	0.91		1.04	0.036		0.041
b		0.5			0.020	
b1	0.38		0.5	0.015		0.020
D			9.8			0.386
E		8.8			0.346	
e		2.54			0.100	
e3		7.62			0.300	
e4		7.62			0.300	
F			7.1			0.280
l			4.8			0.189
L		3.3			0.130	
Z	0.44		1.6	0.017		0.063

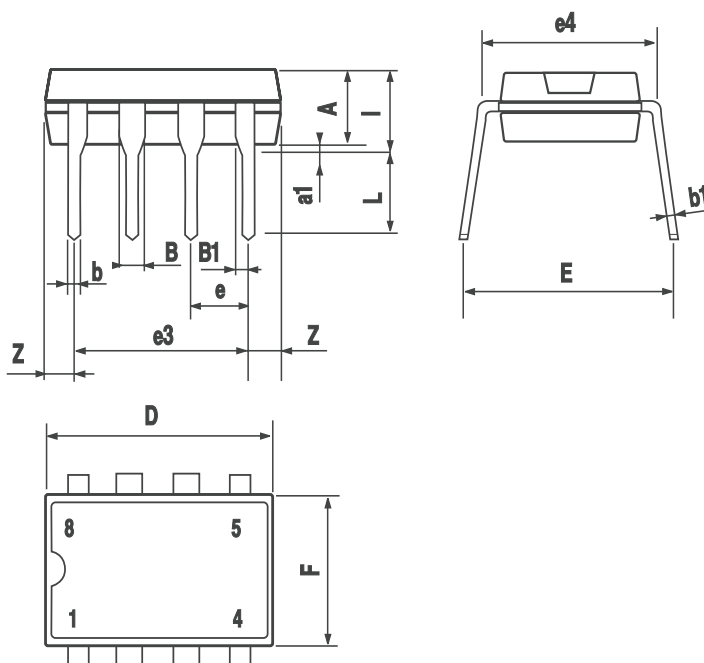

P001F

SO-8 MECHANICAL DATA

DIM.	mm.			inch		
	MIN.	TYP	MAX.	MIN.	TYP.	MAX.
A	1.35		1.75	0.053		0.069
A1	0.10		0.25	0.04		0.010
A2	1.10		1.65	0.043		0.065
B	0.33		0.51	0.013		0.020
C	0.19		0.25	0.007		0.010
D	4.80		5.00	0.189		0.197
E	3.80		4.00	0.150		0.157
e		1.27			0.050	
H	5.80		6.20	0.228		0.244
h	0.25		0.50	0.010		0.020
L	0.40		1.27	0.016		0.050
k	g° (max.)					
ddd			0.1			0.04

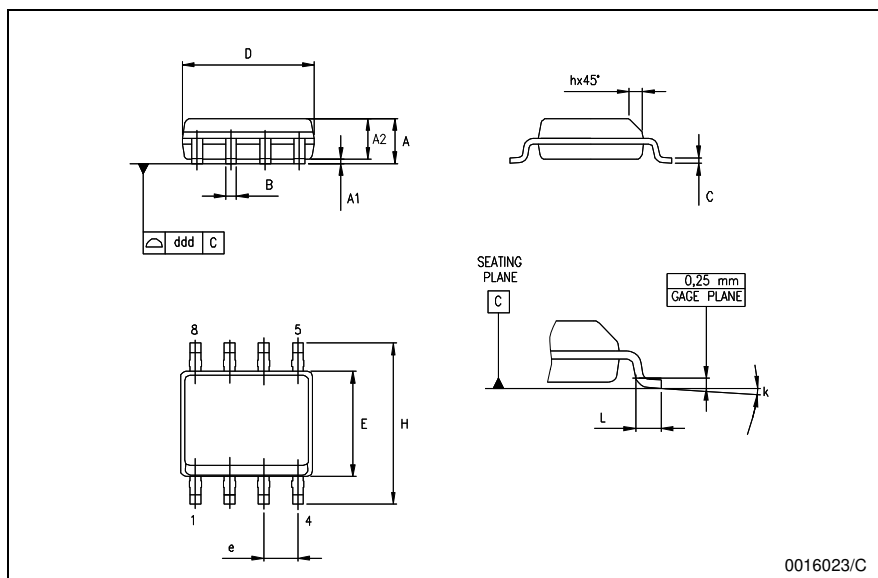

Information furnished is believed to be accurate and reliable. However, STMicroelectronics assumes no responsibility for the consequences of use of such information nor for any infringement of patents or other rights of third parties which may result from its use. No license is granted by implication or otherwise under any patent or patent rights of STMicroelectronics. Specifications mentioned in this publication are subject to change without notice. This publication supersedes and replaces all information previously supplied. STMicroelectronics products are not authorized for use as critical components in life support devices or systems without express written approval of STMicroelectronics.

The ST logo is a registered trademark of STMicroelectronics
All other names are the property of their respective owners

© 2004 STMicroelectronics - All Rights Reserved

STMicroelectronics GROUP OF COMPANIES

Australia - Belgium - Brazil - Canada - China - Czech Republic - Finland - France - Germany - Hong Kong - India - Israel - Italy - Japan
Malaysia - Malta - Morocco - Singapore - Spain - Sweden - Switzerland - United Kingdom - United States

www.st.com