



Chipsmall Limited consists of a professional team with an average of over 10 year of expertise in the distribution of electronic components. Based in Hongkong, we have already established firm and mutual-benefit business relationships with customers from,Europe,America and south Asia,supplying obsolete and hard-to-find components to meet their specific needs.

With the principle of “Quality Parts,Customers Priority,Honest Operation,and Considerate Service”,our business mainly focus on the distribution of electronic components. Line cards we deal with include Microchip,ALPS,ROHM,Xilinx,Pulse,ON,Everlight and Freescale. Main products comprise IC,Modules,Potentiometer,IC Socket,Relay,Connector.Our parts cover such applications as commercial,industrial, and automotives areas.

We are looking forward to setting up business relationship with you and hope to provide you with the best service and solution. Let us make a better world for our industry!



Contact us

Tel: +86-755-8981 8866 Fax: +86-755-8427 6832

Email & Skype: info@chipsmall.com Web: www.chipsmall.com

Address: A1208, Overseas Decoration Building, #122 Zhenhua RD., Futian, Shenzhen, China



Micropower (60 μ A), wide bandwidth (2.4 MHz) CMOS operational amplifiers

Datasheet - production data

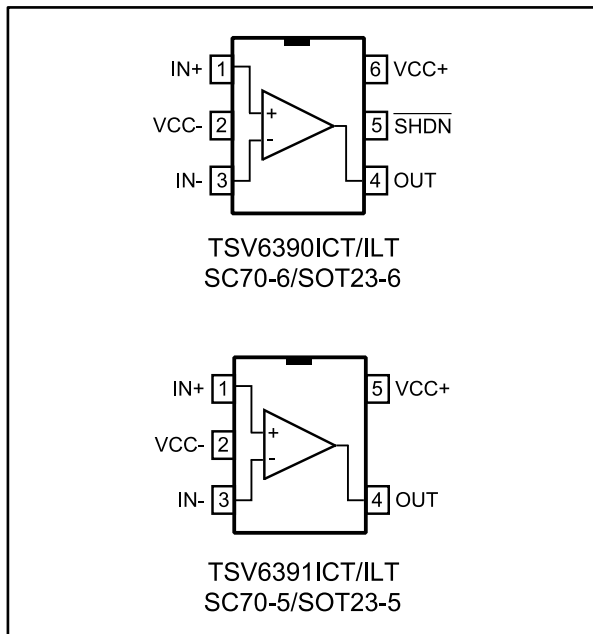

- Signal conditioning
- Active filtering
- Medical instrumentation

Description

The TSV6390, TSV6391, and their "A" versions are single operational amplifiers (op amps) offering low voltage, low power operation, and rail-to-rail input and output.

With a very low input bias current and low offset voltage (500 μ V maximum for the A version), the TSV6390 and TSV6391 are ideal for applications requiring precision. The devices can operate at power supplies ranging from 1.5 to 5.5 V, and are therefore ideal for battery-powered devices, extending battery life.

When used with a gain (above -3 or 4), these products feature an excellent speed/power consumption ratio, offering a 2.4 MHz gain bandwidth product while consuming only 60 μ A at a 5 V supply voltage.

The TSV6390 comes with a shutdown function.

Both the TSV6390 and TSV6391 have a high tolerance to ESD, sustaining 4 kV for the human body model.

They are offered in micropackages, SC70-6 and SOT23-6 for the TSV6390 and SC70-5 and SOT23-5 for the TSV6391. They are guaranteed for industrial temperature ranges from -40 $^{\circ}$ C to 125 $^{\circ}$ C.

All these features combined make the TSV6390 and TSV6391 ideal for sensor interfaces, battery-supplied, and portable applications, as well as active filtering.

Features

- Low offset voltage: 500 μ V max (A version)
- Low power consumption: 60 μ A typ at 5 V
- Low supply voltage: 1.5 V – 5.5 V
- Gain bandwidth product: 2.4 MHz typical
- Stable in gain configuration (-3 or 4)
- Low power shutdown mode: 5 nA typical
- High output current: 63 mA at $V_{CC} = 5$ V
- Low input bias current: 1 pA typical
- Rail-to-rail input and output
- Extended temperature range: -40 $^{\circ}$ C to 125 $^{\circ}$ C
- 4 kV human body model

Applications

- Battery-powered applications
- Portable devices

Contents

1 Absolute maximum ratings and operating conditions 3

2 Electrical characteristics 4

3 Electrical characteristics curves 9

4 Application information 11

 4.1 Operating voltages 11

 4.2 Rail-to-rail input 11

 4.3 Rail-to-rail output 11

 4.4 Shutdown function (TSV6390) 12

 4.5 Optimization of DC and AC parameters 13

 4.6 Driving resistive and capacitive loads 13

 4.7 PCB layouts 13

 4.8 Macromodel 13

5 Package information 14

 5.1 SC70-6 (or SOT323-6) package information 15

 5.2 SOT23-6 package information 17

 5.3 SC70-5 (or SOT323-5) package information 18

 5.4 SOT23-5 package information 19

6 Ordering information 20

7 Revision history 21



1 Absolute maximum ratings and operating conditions

Table 1: Absolute maximum ratings (AMR)

Symbol	Parameter	Value	Unit	
V_{CC}	Supply voltage ⁽¹⁾	6	V	
V_{id}	Differential input voltage ⁽²⁾	$\pm V_{CC}$		
V_{in}	Input voltage ⁽³⁾	$(V_{CC-}) - 0.2$ to $(V_{CC+}) + 0.2$		
I_{in}	Input current ⁽⁴⁾	10	mA	
\overline{SHDN}	Shutdown voltage ⁽³⁾	$(V_{CC-}) - 0.2$ to $(V_{CC+}) + 0.2$	V	
T_{stg}	Storage temperature	-65 to 150	°C	
T_j	Maximum junction temperature	150		
R_{thja}	Thermal resistance junction to ambient ^{(5)/(6)}	SC70-6	232	°C/W
		SOT23-6	240	
		SC70-5	205	
		SOT23-5	250	
ESD	HBM: human body model ⁽⁷⁾	4	kV	
	MM: machine model ⁽⁸⁾	300	V	
	CDM: charged device model ⁽⁹⁾	1.5	kV	
	Latch-up immunity	200	mA	

Notes:

⁽¹⁾All voltage values, except the differential voltage, are with respect to network ground terminal.

⁽²⁾The differential voltage is the non-inverting input terminal with respect to the inverting input terminal.

⁽³⁾ V_{CC-} - V_{in} must not exceed 6 V, V_{in} must not exceed 6 V.

⁽⁴⁾Input current must be limited by a resistor in series with the inputs.

⁽⁵⁾ R_{th} are typical values.

⁽⁶⁾Short-circuits can cause excessive heating and destructive dissipation.

⁽⁷⁾Human body model: 100 pF discharged through a 1.5 k Ω resistor between two pins of the device, done for all couples of pin combinations with other pins floating.

⁽⁸⁾Machine model: a 200 pF capacitor is charged to the specified voltage, then discharged directly between two pins of the device with no external series resistor (internal resistor < 5 Ω), done for all couples of pin combinations with other pins floating.

⁽⁹⁾Charged device model: all pins plus package are charged together to the specified voltage and then discharged directly to the ground.

Table 2: Operating conditions

Symbol	Parameter	Value	Unit
V_{CC}	Supply voltage	1.5 to 5.5	V
V_{icm}	Common mode input voltage range	$(V_{CC-}) - 0.1$ to $(V_{CC+}) + 0.1$	
T_{oper}	Operating free air temperature range	-40 to 125	°C

2 Electrical characteristics

Table 3: Electrical characteristics at $V_{CC+} = 1.8\text{ V}$ with $V_{CC-} = 0\text{ V}$, $V_{icm} = V_{CC}/2$, $T_{amb} = 25\text{ °C}$ and R_L connected to $V_{CC}/2$ (unless otherwise specified)

Symbol	Parameter	Conditions	Min.	Typ.	Max.	Unit
DC performance						
V_{io}	Offset voltage	TSV6390 and TSV6391			3	mV
		TSV6390A and TSV6391A			0.5	
		$T_{min} < T_{op} < T_{max}$, TSV6390 and TSV6391			4.5	
		$T_{min} < T_{op} < T_{max}$, TSV6390A and TSV6391A			2	
$\Delta V_{io}/\Delta T$	Input offset voltage drift			2		$\mu\text{V}/\text{°C}$
I_{io}	Input offset current, $V_{out} = V_{CC}/2$ ⁽¹⁾			1	10	pA
		$T_{min} < T_{op} < T_{max}$			1	
I_{ib}	Input bias current, ($V_{out} = V_{CC}/2$) ⁽¹⁾			1	10	pA
		$T_{min} < T_{op} < T_{max}$			1	
CMR	Common mode rejection ratio $20 \log (\Delta V_{ic}/\Delta V_{io})$	0 V to 1.8 V, $V_{out} = 0.9\text{ V}$	53	74		dB
		$T_{min} < T_{op} < T_{max}$	51			
A_{vd}	Large signal voltage gain	$R_L = 10\text{ k}\Omega$, $V_{out} = 0.5\text{ V to }1.3\text{ V}$	85	95		dB
		$T_{min} < T_{op} < T_{max}$	80			
V_{OH}	High-level output voltage	$R_L = 10\text{ k}\Omega$		5	35	mV
		$T_{min} < T_{op} < T_{max}$			50	
V_{OL}	Low-level output voltage	$R_L = 10\text{ k}\Omega$		4	35	mV
		$T_{min} < T_{op} < T_{max}$			50	
I_{out}	I_{sink}	$V_{out} = 1.8\text{ V}$	6	12		mA
		$T_{min} < T_{op} < T_{max}$	4			
	I_{source}	$V_{out} = 0\text{ V}$	6	10		
		$T_{min} < T_{op} < T_{max}$	4			
I_{CC}	Supply current, $\overline{SHDN} = V_{CC}$	No load, $V_{out} = V_{CC}/2$	40	50	60	μA
		$T_{min} < T_{op} < T_{max}$			62	
AC performance						
GBP	Gain bandwidth product	$R_L = 10\text{ k}\Omega$, $C_L = 100\text{ pF}$		2		MHz
Gain	Minimum gain for stability	Phase margin = 60° , $R_f = 10\text{ k}\Omega$, $R_L = 10\text{ k}\Omega$, $C_L = 20\text{ pF}$		4		V/V
				-3		
SR	Slew rate	$R_L = 10\text{ k}\Omega$, $C_L = 100\text{ pF}$, $V_{out} = 0.5\text{ V to }1.3\text{ V}$		0.7		V/ μs
e_n	Equivalent input noise voltage	$f = 1\text{ kHz}$		60		nV/ $\sqrt{\text{Hz}}$
		$f = 10\text{ kHz}$		33		

Notes:

⁽¹⁾Guaranteed by design.

Table 4: Shutdown characteristics VCC = 1.8 V (TSV6390)

Symbol	Parameter	Conditions	Min.	Typ.	Max.	Unit
DC performance						
I_{CC}	Supply current in shutdown mode (all operators)	$\overline{SHDN} = V_{CC-}$		2.5	50	nA
		$T_{min} < T_{op} < 85\text{ }^{\circ}\text{C}$			200	
		$T_{min} < T_{op} < 125\text{ }^{\circ}\text{C}$			1.5	μA
t_{on}	Amplifier turn-on time	$R_L = 2\text{ k}\Omega$, $V_{out} = (V_{CC-}) \text{ to } (V_{CC-}) + 0.2\text{ V}$		300		ns
t_{off}	Amplifier turn-off time	$R_L = 2\text{ k}\Omega$, $V_{out} = (V_{CC+}) - 0.5\text{ V to } (V_{CC+}) - 0.7\text{ V}$		20		
V_{IH}	\overline{SHDN} logic high		1.3			V
V_{IL}	\overline{SHDN} logic low				0.5	
I_{IH}	\overline{SHDN} current high	$\overline{SHDN} = V_{CC+}$		10		pA
I_{IL}	\overline{SHDN} current low	$\overline{SHDN} = V_{CC-}$		10		
I_{OLeak}	Output leakage in shutdown mode	$\overline{SHDN} = V_{CC-}$		50		
		$T_{min} < T_{op} < T_{max}$		1		nA

Table 5: $V_{CC+} = 3.3\text{ V}$, $V_{CC-} = 0\text{ V}$, $V_{icm} = V_{CC}/2$, $T_{amb} = 25\text{ }^{\circ}\text{C}$, R_L connected to $V_{CC}/2$ (unless otherwise specified)

Symbol	Parameter	Conditions	Min.	Typ.	Max.	Unit
DC performance						
V_{io}	Offset voltage	TSV6390 and TSV6391			3	mV
		TSV6390A and TSV6391A			0.5	
		$T_{min} < T_{op} < T_{max}$, TSV6390 and TSV6391			4.5	
		$T_{min} < T_{op} < T_{max}$, TSV6390A and TSV6391A			2	
$\Delta V_{io}/\Delta T$	Input offset voltage drift			2		$\mu\text{V}/^{\circ}\text{C}$
I_{io}	Input offset current ⁽¹⁾			1	10	pA
		$T_{min} < T_{op} < T_{max}$		1	100	
I_{ib}	Input bias current ⁽¹⁾			1	10	
		$T_{min} < T_{op} < T_{max}$		1	100	
CMR	Common mode rejection ratio $20 \log (\Delta V_{ic}/\Delta V_{io})$	0 V to 3.3 V, $V_{out} = 1.65\text{ V}$	57	79		dB
		$T_{min} < T_{op} < T_{max}$	53			
A_{vd}	Large signal voltage gain	$R_L = 10\text{ k}\Omega$, $V_{out} = 0.5\text{ V to } 2.8\text{ V}$	88	98		
		$T_{min} < T_{op} < T_{max}$	83			
V_{OH}	High-level output voltage	$R_L = 10\text{ k}\Omega$		6	35	mV
		$T_{min} < T_{op} < T_{max}$			50	
V_{OL}	Low-level output voltage	$R_L = 10\text{ k}\Omega$		7	35	
		$T_{min} < T_{op} < T_{max}$			50	
I_{out}	I_{sink}	$V_{out} = 3.3\text{ V}$	23	45		mA
		$T_{min} < T_{op} < T_{max}$	20	42		
	I_{source}	$V_{out} = 0\text{ V}$	23	38		
		$T_{min} < T_{op} < T_{max}$	20			
I_{CC}	Supply current, $\overline{\text{SHDN}} = V_{CC}$	No load, $V_{out} = V_{CC}/2$	43	55	64	μA
		$T_{min} < T_{op} < T_{max}$			66	
AC performance						
GBP	Gain bandwidth product	$R_L = 10\text{ k}\Omega$, $C_L = 100\text{ pF}$		2.2		MHz
Gain	Minimum gain for stability	Phase margin = 60° , $R_f = 10\text{ k}\Omega$, $R_L = 10\text{ k}\Omega$, $C_L = 20\text{ pF}$,		4		V/V
				-3		
SR	Slew rate	$R_L = 10\text{ k}\Omega$, $C_L = 100\text{ pF}$, $V_{out} = 0.5\text{ V to } 2.8\text{ V}$		0.9		V/ μs
e_n	Equivalent input noise voltage	$f = 1\text{ kHz}$		65		nV/ $\sqrt{\text{Hz}}$

Notes:⁽¹⁾Guaranteed by design.

Table 6: Electrical characteristics at VCC+ = 5 V with VCC- = 0 V, Vicm = VCC/2, Tamb = 25 °C and RL connected to VCC/2 (unless otherwise specified)

Symbol	Parameter	Conditions	Min.	Typ.	Max.	Unit
DC performance						
V _{io}	Offset voltage	TSV6390 and TSV6391			3	mV
		TSV6390A and TSV6391A			0.5	
		T _{min} < T _{op} < T _{max} , TSV6390 and TSV6391			4.5	
		T _{min} < T _{op} < T _{max} , TSV6390A and TSV6391A			2	
ΔV _{io} /ΔT	Input offset voltage drift			2		μV/°C
I _{io}	Input offset current, V _{out} = V _{CC} /2 ⁽¹⁾			1	10	pA
		T _{min} < T _{op} < T _{max}		1	100	
I _{ib}	Input bias current, V _{out} = V _{CC} /2 ⁽¹⁾			1	10	pA
		T _{min} < T _{op} < T _{max}		1	100	
CMR	Common mode rejection ratio 20 log (ΔV _{ic} /ΔV _{io})	0 V to 5 V, V _{out} = 2.5 V	60	80		dB
		T _{min} < T _{op} < T _{max}	55			
SVR	Supply voltage rejection ratio 20 log (ΔV _{CC} /ΔV _{io})	V _{CC} = 1.8 to 5 V	75	93		dB
		T _{min} < T _{op} < T _{max}	73			
A _{vd}	Large signal voltage gain	R _L = 10 kΩ, V _{out} = 0.5 V to 4.5 V	89	98		
		T _{min} < T _{op} < T _{max}	84			
V _{OH}	High-level output voltage	R _L = 10 kΩ		7	35	mV
		T _{min} < T _{op} < T _{max}			50	
V _{OL}	Low-level output voltage	R _L = 10 kΩ		6	35	mV
		T _{min} < T _{op} < T _{max}			50	
I _{out}	I _{sink}	V _{out} = 5 V	40	65		mA
		T _{min} < T _{op} < T _{max}	35			
	I _{source}	V _{out} = 0 V	40	72		
		T _{min} < T _{op} < T _{max}	35			
I _{CC}	Supply current, $\overline{\text{SHDN}} = V_{CC}$	No load, V _{out} = V _{CC} /2	50	60	69	μA
		T _{min} < T _{op} < T _{max}			72	
AC performance						
GBP	Gain bandwidth product	R _L = 10 kΩ, C _L = 100 pF		2.4		MHz
Gain	Minimum gain for stability	Phase margin = 60°, R _f = 10 kΩ, R _L = 10 kΩ, C _L = 20 pF,		4		V/V
				-3		
SR	Slew rate	R _L = 10 kΩ, C _L = 100 pF		1.1		V/μs
e _n	Equivalent input noise voltage	f = 1 kHz		60		nV/√Hz
		f = 10 kHz		33		
THD+N	Total harmonic distortion + noise	A _v = -10, f _{in} = 1 kHz, R = 100 kΩ, V _{icm} = V _{CC} /2, V _{in} = 40 mVpp		0.11		%

Notes:

⁽¹⁾Guaranteed by design.



Table 7: Shutdown characteristics VCC = 5 V (TSV6390)

Symbol	Parameter	Conditions	Min.	Typ.	Max.	Unit
DC performance						
I_{CC}	Supply current in shutdown mode (all operators)	$\overline{SHDN} = V_{CC-}$		5	50	nA
		$T_{min} < T_{op} < 85\text{ }^{\circ}\text{C}$			200	
		$T_{min} < T_{op} < 125\text{ }^{\circ}\text{C}$			1.5	μA
t_{on}	Amplifier turn-on time	$R_L = 2\text{ k}\Omega$, $V_{out} = (V_{CC-}) \text{ to } (V_{CC-}) + 0.2\text{ V}$		300		ns
t_{off}	Amplifier turn-off time	$R_L = 2\text{ k}\Omega$, $V_{out} = (V_{CC+}) - 0.5\text{ V to } (V_{CC+}) - 0.7\text{ V}$		30		
V_{IH}	\overline{SHDN} logic high		4.5			V
V_{IL}	\overline{SHDN} logic low				0.5	
I_{IH}	\overline{SHDN} current high	$\overline{SHDN} = V_{CC+}$		10		pA
I_{IL}	\overline{SHDN} current low	$\overline{SHDN} = V_{CC-}$		10		
I_{OLeak}	Output leakage in shutdown mode	$\overline{SHDN} = V_{CC-}$		50		
		$T_{min} < T_{op} < T_{max}$		1		nA

3 Electrical characteristics curves

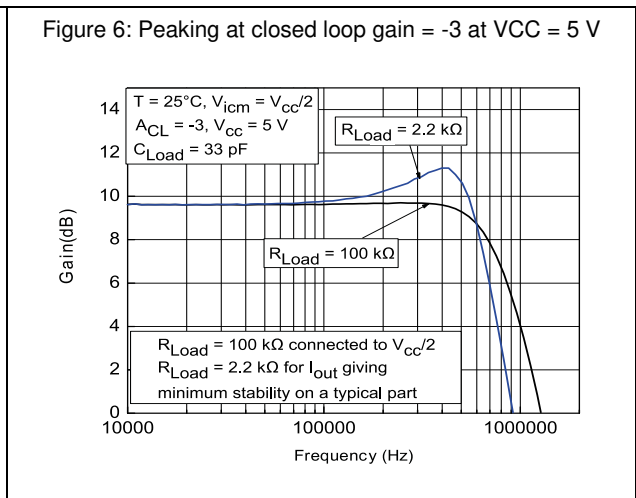
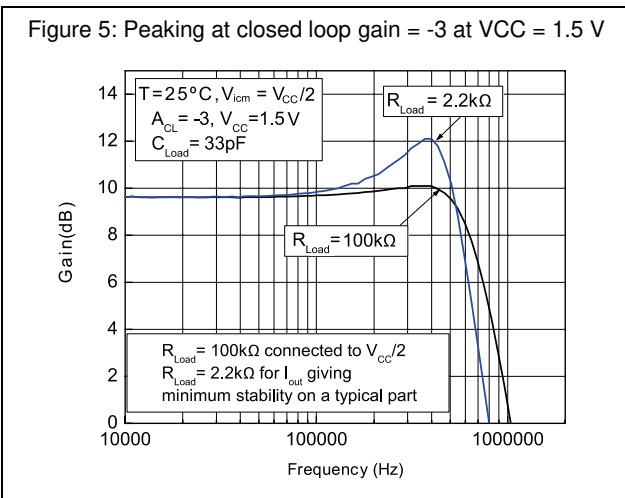
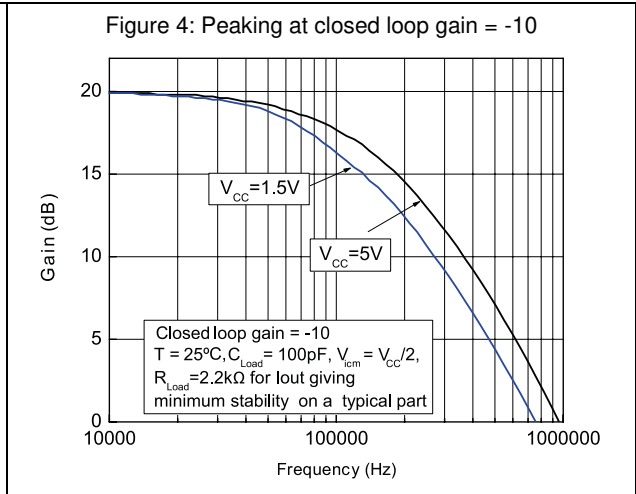
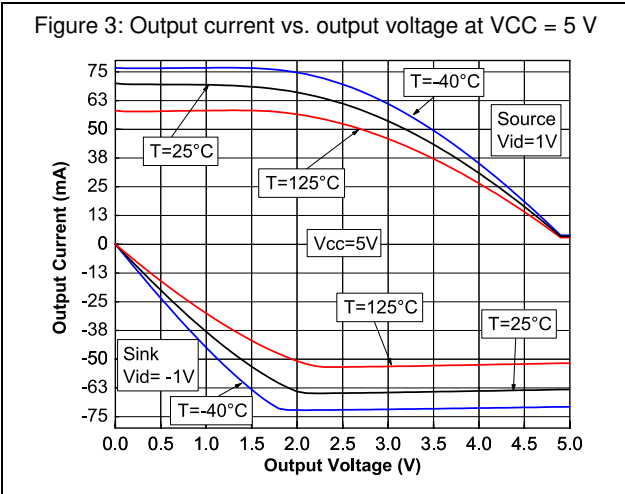
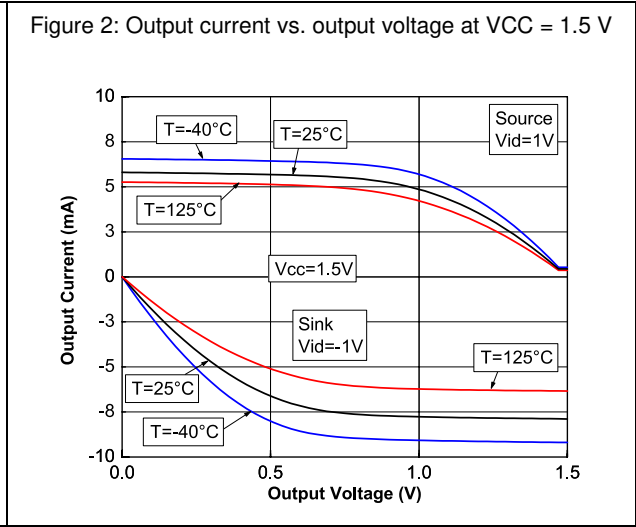
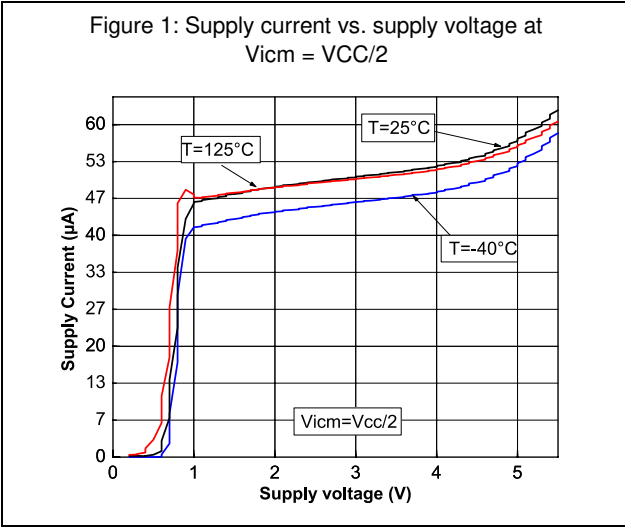

Electrical characteristics curves

TSV6390, TSV6390A, TSV6391, TSV6391A

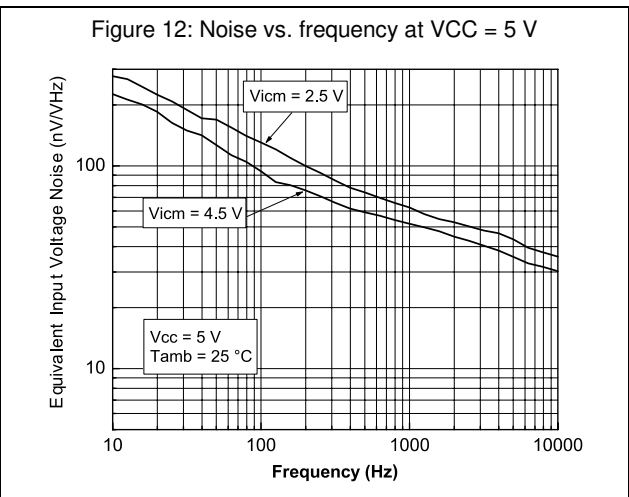
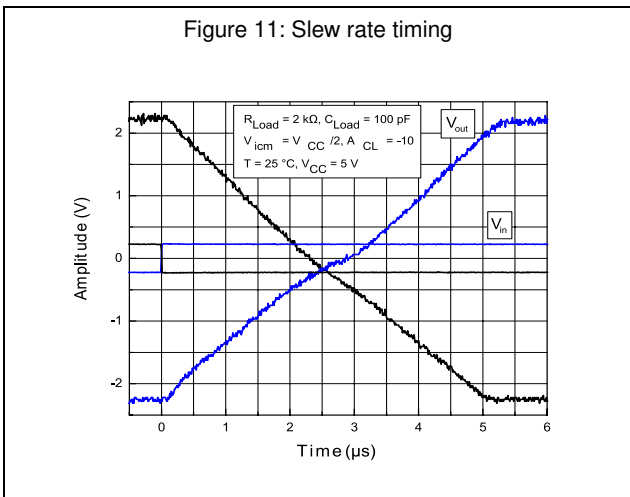
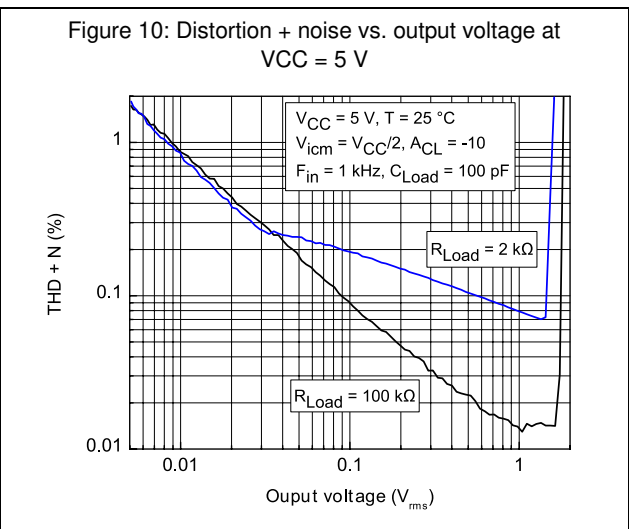
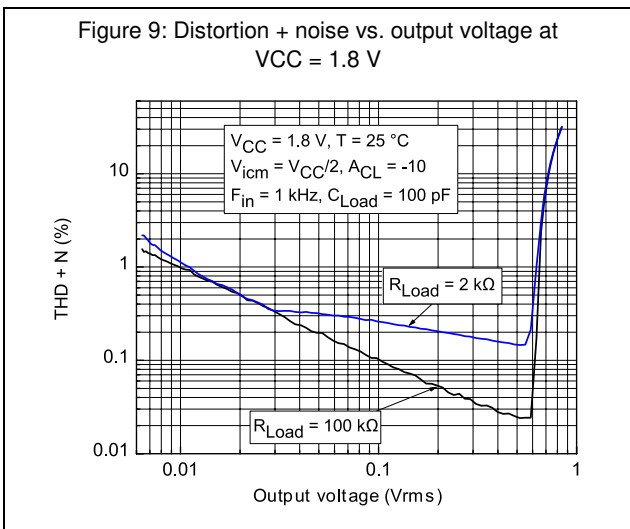
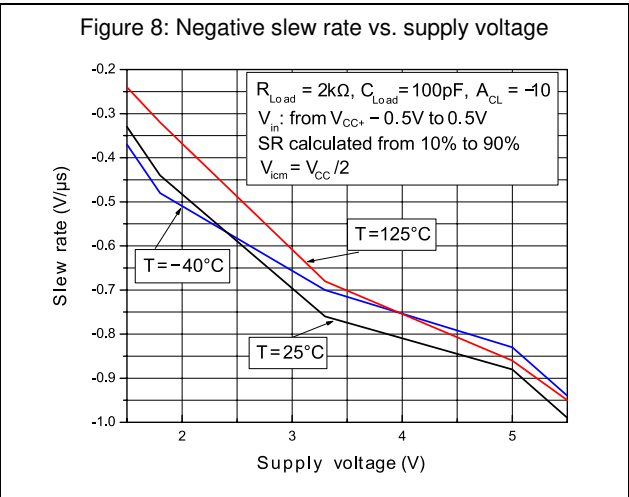
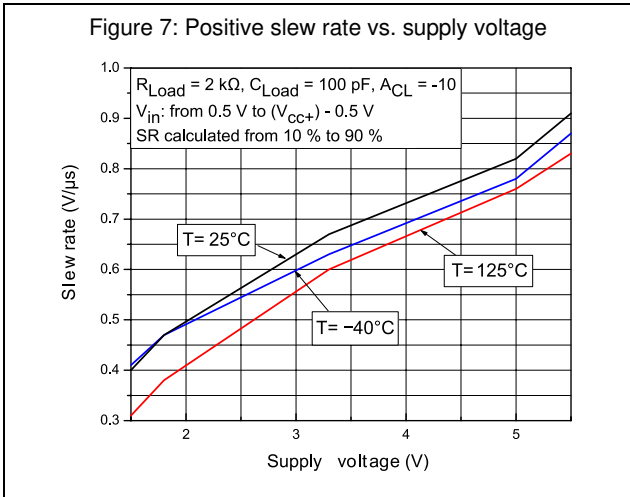

4 Application information

4.1 Operating voltages

The TSV6390 and TSV6391 can operate from 1.5 to 5.5 V. Their parameters are fully specified for 1.8, 3.3 and 5 V power supplies. However, the parameters are very stable in the full V_{CC} range and several characterization curves show the TSV639x characteristics at 1.5 V. Additionally, the main specifications are guaranteed in extended temperature ranges from -40 °C to 125 °C.

4.2 Rail-to-rail input

The TSV6390 and TSV6391 are built with two complementary PMOS and NMOS input differential pairs. The devices have a rail-to-rail input, and the input common mode range is extended from $(V_{CC-}) - 0.1$ V to $(V_{CC+}) + 0.1$ V. The transition between the two pairs appears at $(V_{CC+}) - 0.7$ V. In the transition region, the performance of CMRR, PSRR, V_{io} , and THD is slightly degraded (as shown in [Figure 13](#) and [Figure 14](#) for V_{io} vs. V_{icm}).

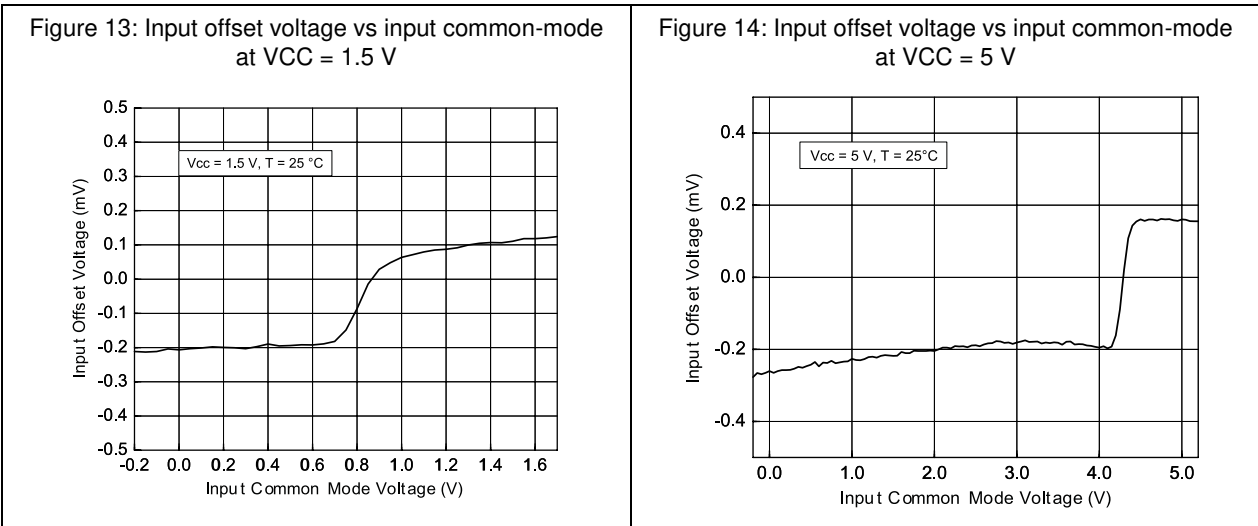

The devices are guaranteed without phase reversal.

4.3 Rail-to-rail output

The operational amplifiers' output levels can go close to the rails: 35 mV maximum above and below the rail when connected to a 10 kΩ resistive load to $V_{CC}/2$.

4.4 Shutdown function (TSV6390)

The operational amplifier is enabled when the $\overline{\text{SHDN}}$ pin is pulled high. To disable the amplifier, the $\overline{\text{SHDN}}$ must be pulled down to $V_{\text{CC-}}$. When in shutdown mode, the amplifier's output is in a high impedance state. The $\overline{\text{SHDN}}$ pin must never be left floating, but kept tied to $V_{\text{CC+}}$ or $V_{\text{CC-}}$.

The turn-on and turn-off times are calculated for an output variation of ± 200 mV (Figure 15 and Figure 16 show the test configurations).

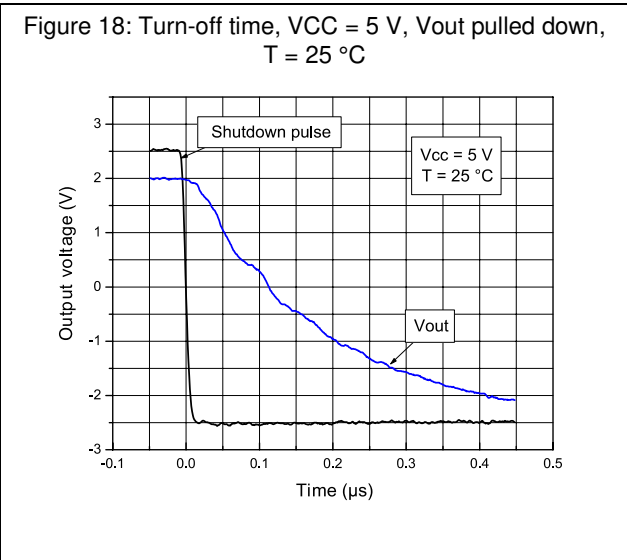
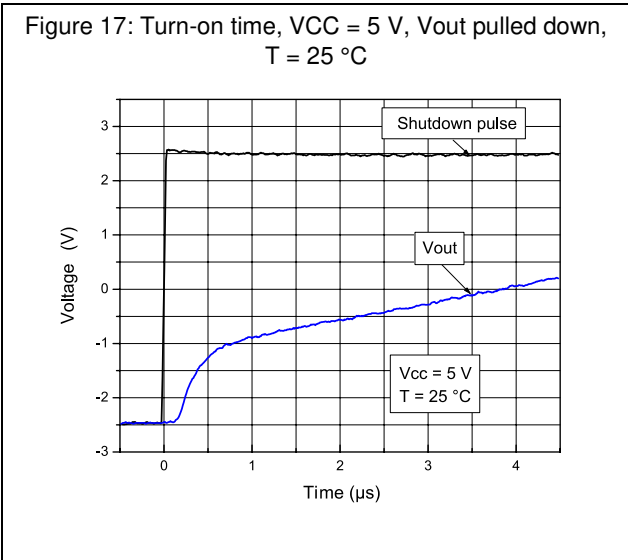
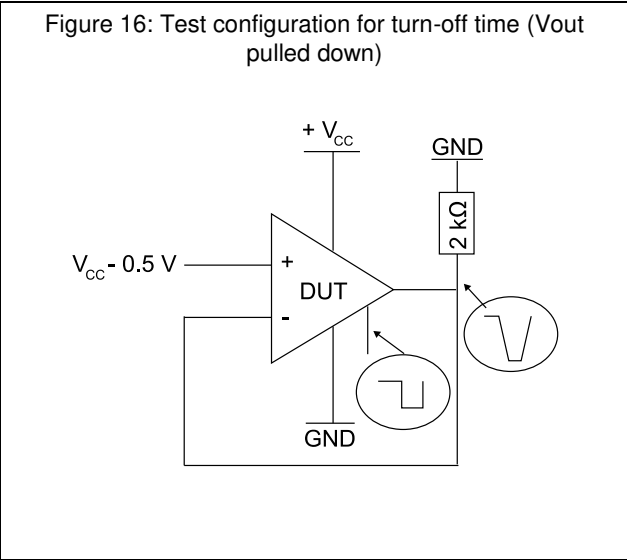
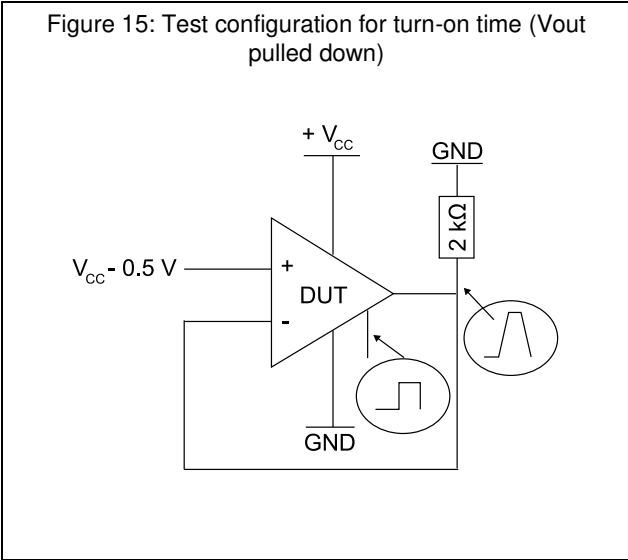

4.5 Optimization of DC and AC parameters

These devices use an innovative approach to reduce the spread of the main DC and AC parameters. An internal adjustment achieves a very narrow spread of the current consumption (60 μA typical, min/max at $\pm 17\%$). Parameters linked to the current consumption value, such as GBP, SR, and A_{vd} , benefit from this narrow dispersion.

4.6 Driving resistive and capacitive loads

These products are micropower, low-voltage operational amplifiers optimized to drive rather large resistive loads, above 2 k Ω . For lower resistive loads, the THD level may significantly increase.

These operational amplifiers have a relatively low internal compensation capacitor, making them very fast while consuming very little. They are ideal when used in a non-inverting configuration or in an inverting configuration in the following conditions.

- $|Gain| \geq 3$ in an inverting configuration ($C_L = 20$ pF, $R_L = 100$ k Ω) or $|gain| \geq 10$, ($C_L = 100$ pF, $R_L = 100$ k Ω)
- $Gain \geq 4$ in a non-inverting configuration ($C_L = 20$ pF, $R_L = 100$ k Ω) or $gain \geq 11$, ($C_L = 100$ pF, $R_L = 100$ k Ω)

As these operational amplifiers are not unity gain stable, for a low closed-loop gain it is recommended to use the TSV62x (29 μA , 420 kHz) or TSV63x (60 μA , 880 kHz) which are unity gain stable.

Table 8: Related products

Part #	I _{cc} (μA) at 5 V	GBP (MHz)	SR (V/ μs)	Minimum gain for stability ($C_{Load} = 100$ pF)
TSV620-1	29	0.42	0.14	1
TSV6290-1	29	1.3	0.5	11
TSV630-1	60	0.88	0.34	1
TSV6390-1	60	2.4	1.1	11

4.7 PCB layouts

For correct operation, it is advised to add 10 nF decoupling capacitors as close as possible to the power supply pins.

4.8 Macromodel

An accurate macromodel of the TSV6390 and TSV6391 is available on STMicroelectronics' web site at: www.st.com. This model is a trade-off between accuracy and complexity (that is, time simulation) of the TSV639x operational amplifiers. It emulates the nominal performances of a typical device within the specified operating conditions mentioned in the datasheet. It also helps to validate a design approach and to select the right operational amplifier, *but it does not replace on-board measurements*.

5 Package information

In order to meet environmental requirements, ST offers these devices in different grades of ECOPACK[®] packages, depending on their level of environmental compliance. ECOPACK[®] specifications, grade definitions and product status are available at: www.st.com. ECOPACK[®] is an ST trademark.

5.1 SC70-6 (or SOT323-6) package information

Figure 19: SC70-6 (or SOT323-6) package outline

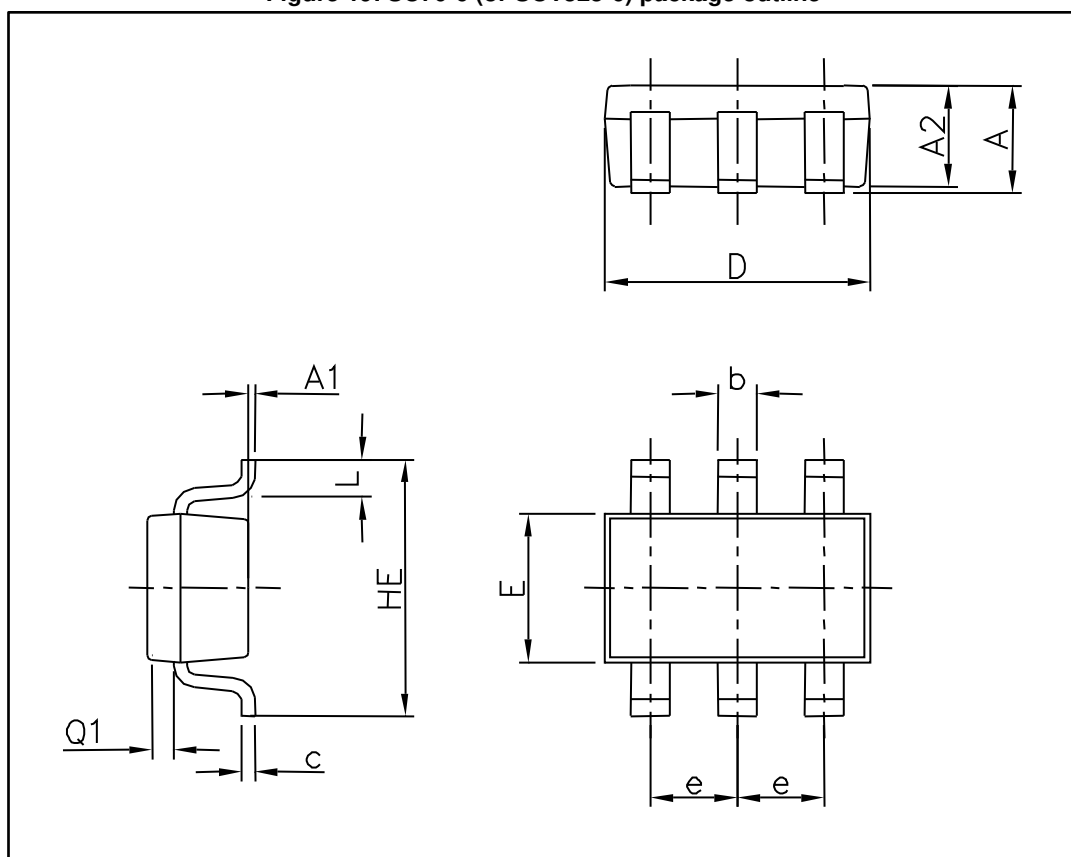
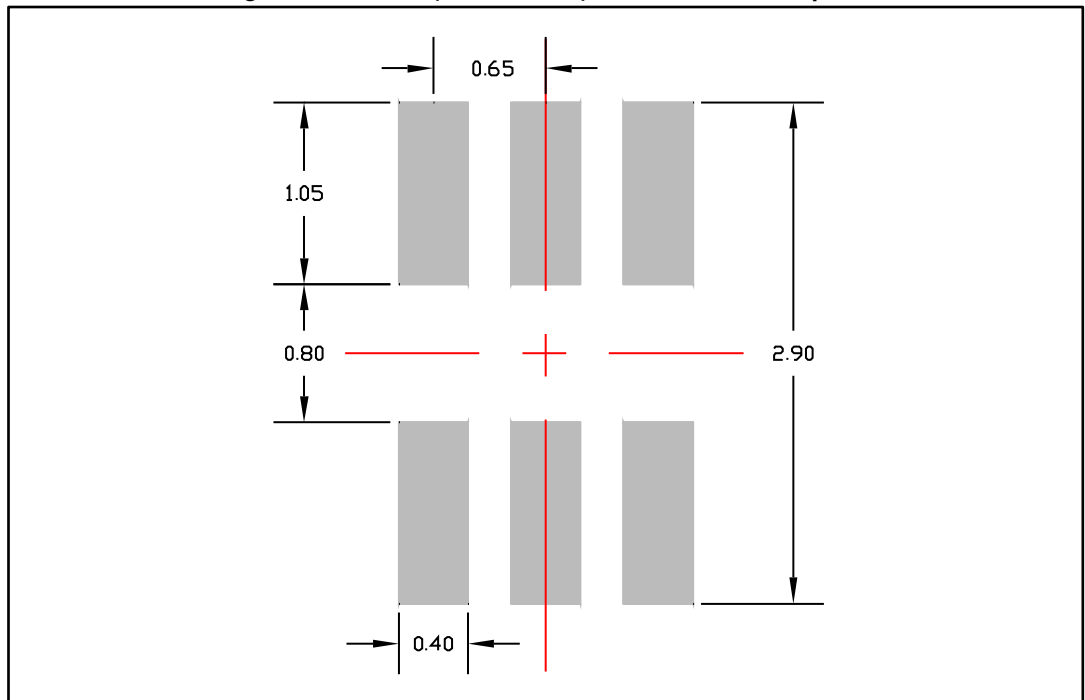

Table 9: SC70-6 (or SOT323-6) mechanical data

Ref	Dimensions					
	Millimeters			Inches		
	Min.	Typ.	Max.	Min.	Typ.	Max.
A	0.80		1.10	0.031		0.043
A1			0.10			0.004
A2	0.80		1.00	0.031		0.039
b	0.15		0.30	0.006		0.012
c	0.10		0.18	0.004		0.007
D	1.80		2.20	0.071		0.086
E	1.15		1.35	0.045		0.053
e		0.65			0.026	
HE	1.80		2.40	0.071		0.094
L	0.10		0.40	0.004		0.016
Q1	0.10		0.40	0.004		0.016

Figure 20: SC70-6 (or SOT323-6) recommended footprint



5.2 SOT23-6 package information

Figure 21: SOT23-6 package outline

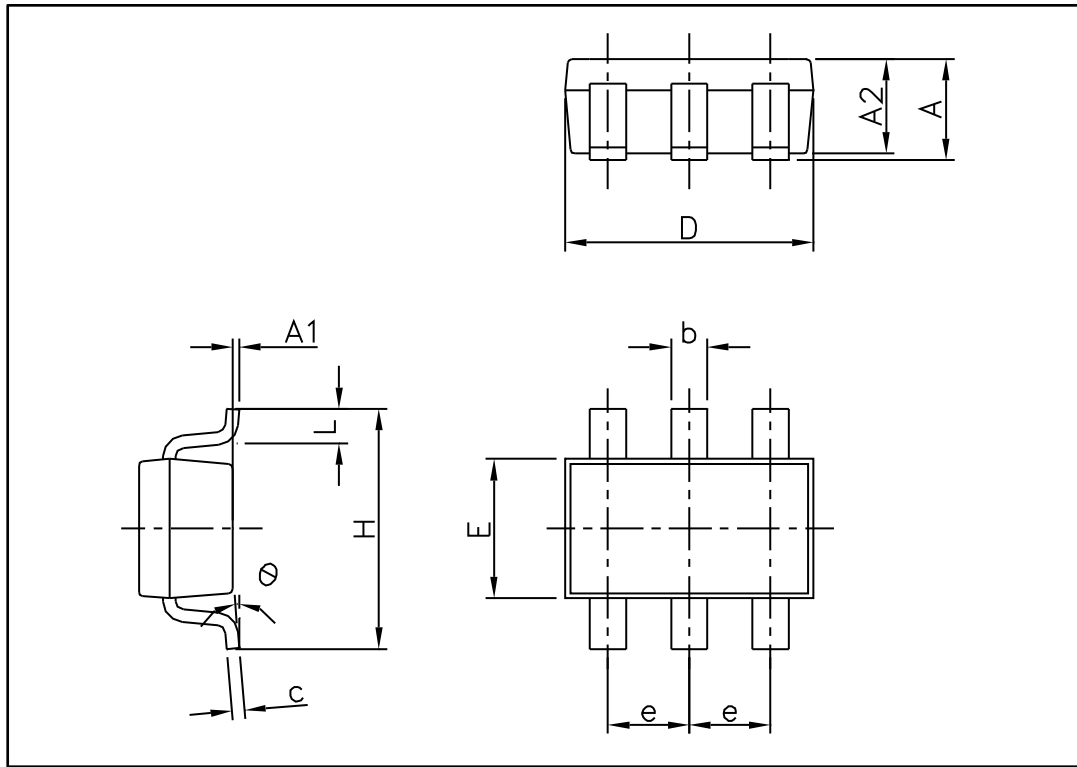

Table 10: SOT23-6 mechanical data

Ref.	Dimensions					
	Millimeters			Inches		
	Min.	Typ.	Max.	Min.	Typ.	Max.
A	0.90		1.45	0.035		0.057
A1			0.10			0.004
A2	0.90		1.30	0.035		0.051
b	0.35		0.50	0.013		0.019
c	0.09		0.20	0.003		0.008
D	2.80		3.05	0.110		0.120
E	1.50		1.75	0.060		0.069
e		0.95			0.037	
H	2.60		3.00	0.102		0.118
L	0.10		0.60	0.004		0.024
θ	0°		10°	0°		10°

5.3 SC70-5 (or SOT323-5) package information

Figure 22: SC70-5 (or SOT323-5) package outline

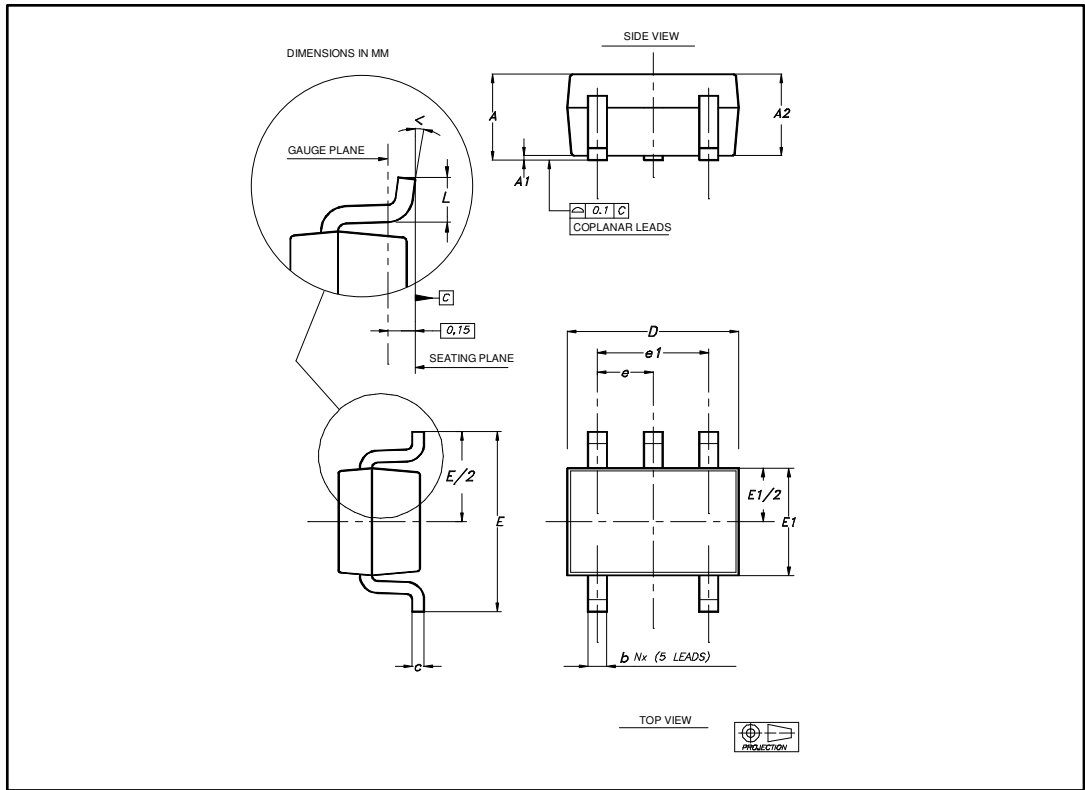

Table 11: SC70-5 (or SOT323-5) mechanical data

Ref.	Dimensions					
	Millimeters			Inches		
	Min.	Typ.	Max.	Min.	Typ.	Max.
A	0.80		1.10	0.315		0.043
A1			0.10			0.004
A2	0.80	0.90	1.00	0.315	0.035	0.039
b	0.15		0.30	0.006		0.012
c	0.10		0.22	0.004		0.009
D	1.80	2.00	2.20	0.071	0.079	0.087
E	1.80	2.10	2.40	0.071	0.083	0.094
E1	1.15	1.25	1.35	0.045	0.049	0.053
e		0.65			0.025	
e1		1.30			0.051	
L	0.26	0.36	0.46	0.010	0.014	0.018
<	0°		8°	0°		8°

5.4 SOT23-5 package information

Figure 23: SOT23-5 package outline

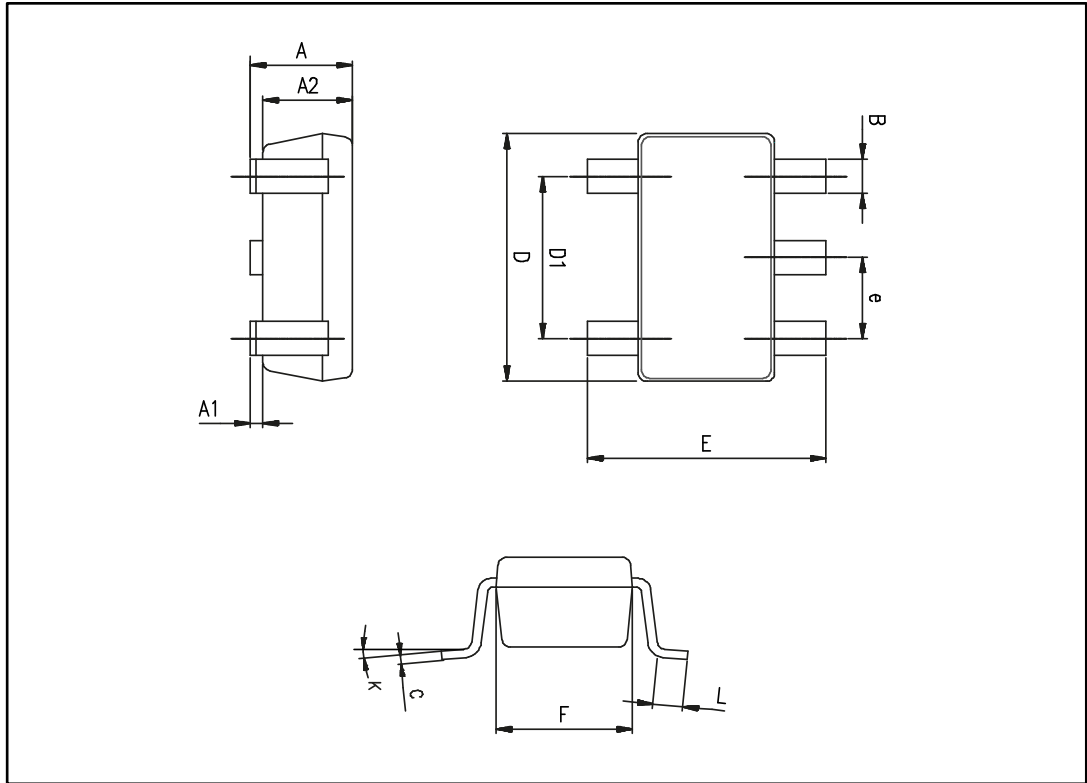

Table 12: SOT23-5 mechanical data

Ref.	Dimensions					
	Millimeters			Inches		
	Min.	Typ.	Max.	Min.	Typ.	Max.
A	0.90	1.20	1.45	0.035	0.047	0.057
A1			0.15			0.006
A2	0.90	1.05	1.30	0.035	0.041	0.051
B	0.35	0.40	0.50	0.014	0.016	0.020
C	0.09	0.15	0.20	0.004	0.006	0.008
D	2.80	2.90	3.00	0.110	0.114	0.118
D1		1.90			0.075	
e		0.95			0.037	
E	2.60	2.80	3.00	0.102	0.110	0.118
F	1.50	1.60	1.75	0.059	0.063	0.069
L	0.10	0.35	0.60	0.004	0.014	0.024
K	0 degrees		10 degrees	0 degrees		10 degrees

6 Ordering information

Table 13: Order codes

Part number	Temperature range	Package	Packing	Marking
TSV6390ILT	-40 °C to 125 °C	SOT23-6	Tape and reel	K109
TSV6390ICT		SC70-6		K19
TSV6390AILT		SOT23-6		K142
TSV6390AICT		SC70-6		K42
TSV6391ILT		SOT23-5		K108
TSV6391ICT		SC70-5		K20
TSV6391AILT		SOT23-5		K141
TSV6391AICT		SC70-5		K41

7 Revision history

Table 14: Document revision history

Date	Revision	Changes
09-Mar-2010	1	Initial release.
04-Dec-2015	2	Updated layout <i>Section 2: "Electrical characteristics"</i> : replaced DV_{iO} by $\Delta V_{iO}/\Delta T$ and updated V_{OH} values. In <i>Table 7</i> , updated t_{off} conditions. <i>Electrical characteristic curves</i> : updated Y-axes of <i>Figure 7</i> and <i>Figure 8</i> . <i>Shutdown function (TSV6390)</i> : updated X-axes of <i>Figure 17</i> and <i>Figure 18</i> . <i>Table 10</i> : replaced ° with θ

IMPORTANT NOTICE – PLEASE READ CAREFULLY

STMicroelectronics NV and its subsidiaries ("ST") reserve the right to make changes, corrections, enhancements, modifications, and improvements to ST products and/or to this document at any time without notice. Purchasers should obtain the latest relevant information on ST products before placing orders. ST products are sold pursuant to ST's terms and conditions of sale in place at the time of order acknowledgement.

Purchasers are solely responsible for the choice, selection, and use of ST products and ST assumes no liability for application assistance or the design of Purchasers' products.

No license, express or implied, to any intellectual property right is granted by ST herein.

Resale of ST products with provisions different from the information set forth herein shall void any warranty granted by ST for such product.

ST and the ST logo are trademarks of ST. All other product or service names are the property of their respective owners.

Information in this document supersedes and replaces information previously supplied in any prior versions of this document.

© 2015 STMicroelectronics – All rights reserved