



Chipsmall Limited consists of a professional team with an average of over 10 year of expertise in the distribution of electronic components. Based in Hongkong, we have already established firm and mutual-benefit business relationships with customers from,Europe,America and south Asia,supplying obsolete and hard-to-find components to meet their specific needs.

With the principle of “Quality Parts,Customers Priority,Honest Operation,and Considerate Service”,our business mainly focus on the distribution of electronic components. Line cards we deal with include Microchip,ALPS,ROHM,Xilinx,Pulse,ON,Everlight and Freescale. Main products comprise IC,Modules,Potentiometer,IC Socket,Relay,Connector.Our parts cover such applications as commercial,industrial, and automotives areas.

We are looking forward to setting up business relationship with you and hope to provide you with the best service and solution. Let us make a better world for our industry!



Contact us

Tel: +86-755-8981 8866 Fax: +86-755-8427 6832

Email & Skype: info@chipsmall.com Web: www.chipsmall.com

Address: A1208, Overseas Decoration Building, #122 Zhenhua RD., Futian, Shenzhen, China



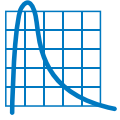

T H E R M O M E T R I C S
A C O M M I T M E N T T O E X C E L L E N C E

TSW-10 Turbidity Sensor

The TSW-10 module measures the turbidity (amount of suspended particles) of the wash water in washing machines and dishwashers. An optical sensor for washing machines is a measuring product for a turbid water density or an extraneous matter concentration using the refraction of wavelength between photo transistor and diode. By using an optical transistor and optical diodes, an optical washing machine sensor measures the amount of light coming from the source of the light to the light receiver, in order to calculate water turbidity.



Amphenol
Advanced Sensors

Theory of Operation

The sensor operates on the principle that when light is passed through a sample of water, the amount of light transmitted through the sample is dependent on the amount of soil in the water. As the soil level increases, the amount of transmitted light decreases. The turbidity sensor measures the amount of transmitted light to determine the turbidity of the wash water. These turbidity measurements are supplied to the washer controller, which makes decisions on how long to wash in all the cycles. These decisions are made based on a comparison between clean water measurements (taken at the beginning of the wash cycle) and the wash water turbidity measurement taken at the end of each wash cycle. By measuring the turbidity of the wash water, the washing machine can conserve energy on lightly soiled loads by only washing as long as necessary. This will result in energy savings for the consumer.

Specifications

Part Number

TSW-10

Rated Voltage

DC 5V (between No #1 & Ground)

Voltage Differential

1.3V \pm 20%

Test Method

After testing voltage in water (0 NTU),
voltage test in water (1000 NTU)
(Turbidity level Calibration -> Master NTU standard liquid)
(Voltage between No #2 pin & Ground)

Operating Temperature Range

-30°C ~ 80°C

Storage Temperature Range

-10°C~ 80°C

Rated Current

Max. 30 mA

Insulation Resistance

Min 100 M Ω by 500V DC

Application Section

Detecting the turbidity degree of water

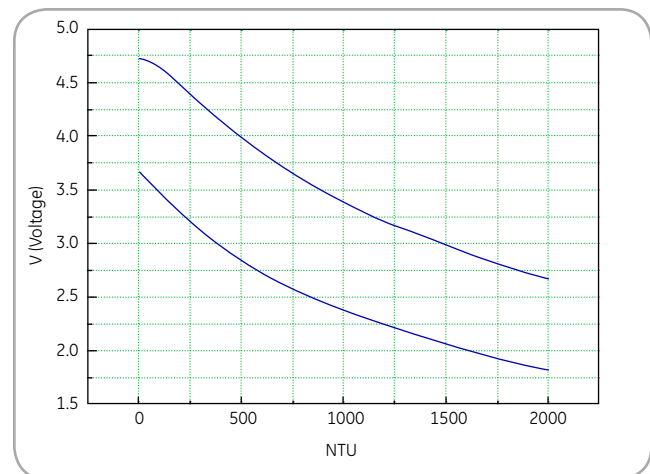
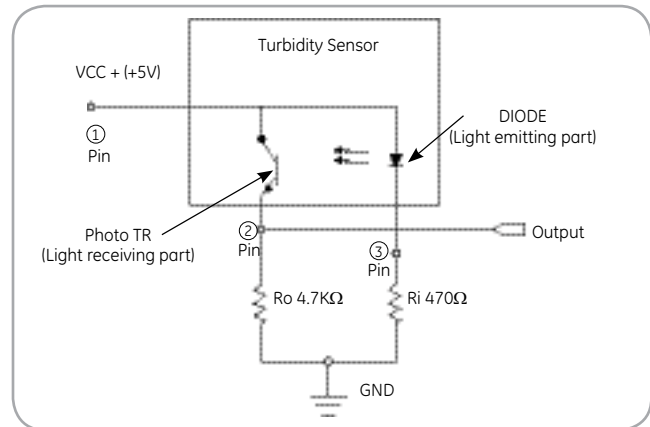
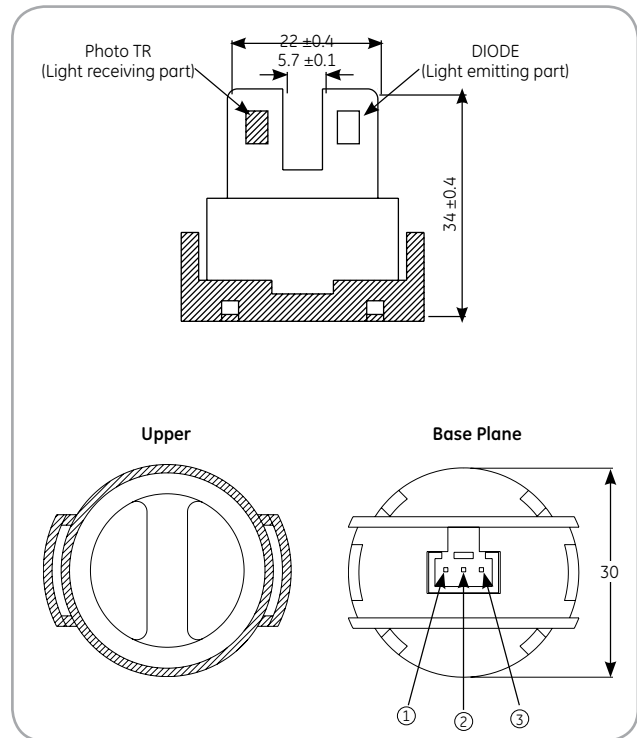

Amphenol
Advanced Sensors

www.amphenol-sensors.com

© 2014 Amphenol Corporation. All Rights Reserved. Specifications are subject to change without notice. Other company names and product names used in this document are the registered trademarks or trademarks of their respective owners.

AAS-920-479B-03/2014