



Chipsmall Limited consists of a professional team with an average of over 10 year of expertise in the distribution of electronic components. Based in Hongkong, we have already established firm and mutual-benefit business relationships with customers from,Europe,America and south Asia,supplying obsolete and hard-to-find components to meet their specific needs.

With the principle of “Quality Parts,Customers Priority,Honest Operation,and Considerate Service”,our business mainly focus on the distribution of electronic components. Line cards we deal with include Microchip,ALPS,ROHM,Xilinx,Pulse,ON,Everlight and Freescale. Main products comprise IC,Modules,Potentiometer,IC Socket,Relay,Connector.Our parts cover such applications as commercial,industrial, and automotives areas.

We are looking forward to setting up business relationship with you and hope to provide you with the best service and solution. Let us make a better world for our industry!



Contact us

Tel: +86-755-8981 8866 Fax: +86-755-8427 6832

Email & Skype: info@chipsmall.com Web: www.chipsmall.com

Address: A1208, Overseas Decoration Building, #122 Zhenhua RD., Futian, Shenzhen, China





WIRELESS CHARGING

User Guide

TSWIRX-5V2-EVM

Low Power Wireless Charging Receiver

(Rev 3.00)

Introduction

The Semtech TSWIRX-5V2-EVM is an evaluation platform for the test and experimentation of a wireless charging receiver based on the Semtech TS51223 fully-integrated IC for Wireless Power Receiver Applications. This evaluation module, in conjunction with its compatible transmitter - TSWITX-G2-EVM/TSWITX-G4-EVM, providing a complete system solution for low-power, wearable power transmission and receiving.

Objectives

The objective of this User Guide is to provide a fast, easy and thorough method to experiment with and evaluate the Semtech solutions for wireless charging systems. Sufficient information is provided to support the engineer in all aspects of adding wireless charging support to their products. Semtech offers a range of solutions to meet the needs of a wide range of system developers. Developers are provided with all the information on how this EVM was built as a starting point for their own designs based on the TS51223.

Table of Contents

<i>Wireless Charging Concepts</i>	2
<i>Product Description</i>	3
<i>Standard Use</i>	4
<i>Documentation</i>	7
A. Block Diagram.....	7
B. Schematic	8
C. Bill Of Materials “BOM”	10
D. Board Layout.....	11
E. Board Layers.....	12
<i>FAQs</i>	13
<i>Next Steps</i>	14

Wireless Charging Concepts

Wireless power transfer is, essentially, a transformer. Power is provided to a primary coil which produces an electromagnetic (EM) field. In this field, a secondary coil is placed. The EM field induces a current into the secondary coil, providing power to whatever it is connected to.

However, unlike a conventional power transformer that operates at line frequencies and requires an iron core for efficiency, low power wireless power systems for wearable devices have been designed to operate in the 1 MHz range, and thus can perform efficiently with an air core. As such, the primary and secondary windings, if closely spaced, can be in separate devices, the primary being part of a transmitter and the secondary within a receiver. This implementation can also be described as a radio broadcast process, and as such, these transformer coils can also be seen as antennas with equal validity, and the two terms will be used interchangeably in this text.

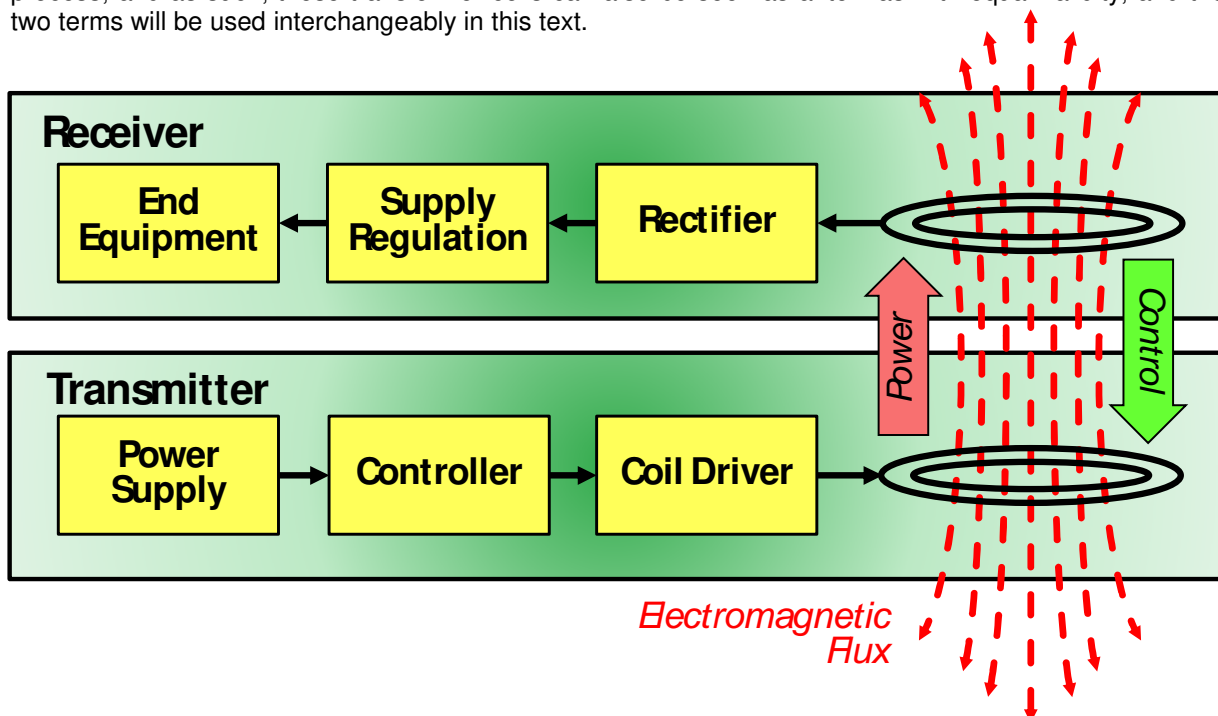

Wireless power systems differ in another major aspect from conventional transformers, in that they are intelligently managed. A transmitter will only provide power when a receiver is present, and only produce the amount of power requested by the receiver. The intelligent management of the wireless power transmission process is achieved through the programming of the transmitter-resident TS80002, which first searches for a receiver. Once found, the receiver informs the transmitter of its power requirements, and transmission begins. The system then verifies the right amount of power is being sent. The receiver continually provides ongoing requests for power to maintain the transaction. If the requests cease, the transaction terminates. Via this protocol, even complex charging patterns can be supported, as the transmitter can provide varying amounts of power at different times, as requested by the receiver. Should the receiver require no further power, such as when a battery charge is completed, it can request no further power be sent, and the transmitter will reduce its output accordingly.

Wireless power systems have been broken into three basic power categories. “Wearable” devices, such as headsets, wrist-band devices, medical sensors, and so forth - all operate in the low power range, up to 5 watts. Medium power devices, in the 5- to 15-watt range, include most handheld devices, such as cell phones, tablets, and medical electronics. High power wireless systems are intended to support devices such as power tools, radio controlled (“RC”) devices such as drones, and other equipment requiring 15 to 100 watts of power.

Product Description

The TSWIRX-5V2-EVM Evaluation Module is a ready-to-use demonstration platform allowing testing of approximately 1.25 watt of wireless power transmission. Its output power will range from about 0.5 to 2 watts depending on antenna coil selection.

The receiver is coupled with its compatible transmitter module, the Semtech TSWITX-G2-EVM/TSWITX-G4-EVM, to form a complete wireless power transmission system. Together, they allow a variety of experiments to easily be performed in order to learn more about the behavior of the system.

Those who wish to develop their own board, or integrate this functionality into an existing system can use the EVM as a starting point for their design, as it demonstrates a working model from which to proceed. Toward this end, all documentation for the EVM is provided to make the process as efficient as possible.

The key technology in the EVM is the Semtech TS51223, which is a fully-integrated wireless power receiver for low-power, wearable applications that require a space-saving solution. Its 1 MHz switching frequency enables the use of small inductive components resulting in minimal board space and reduced costs. It integrates a wide range of protection circuitry including input supply under-voltage lockout, output voltage soft start, current limiting, and thermal shutdown.

In this user guide, an introduction will be provided to the evaluator for how to use the EVM for wireless power transmission as well as how the TSWITX-G2-EVM/TSWITX-G4-EVM can be used in conjunction with it.

Once the system is set up and working, a selection of tests and activities will be described that the evaluator can choose to perform.

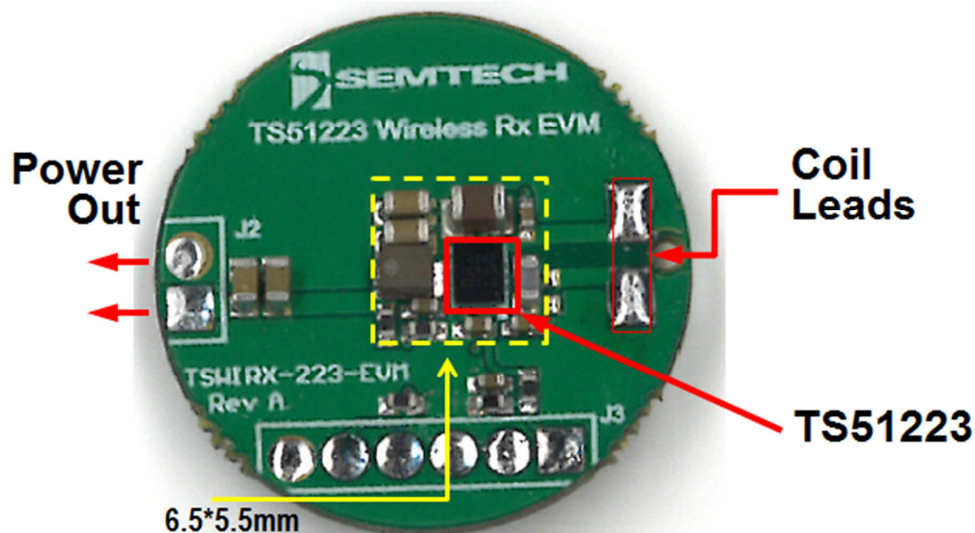

Standard Use

The TSWIRX-5V2-EVM is easy to set up and use. Connect a USB cable from any USB port capable of driving up to 2 watts (most PCs will suffice) to the USB port on the TSWITX-G2-EVM/TSWITX-G4-EVM. On application of power, its green LED should light, indicating the board is now active.

At this point, the transmitter EVM is ready to transmit power. A few times each second, the transmitter emits a 'ping' of energy in search of a compliant receiver in range.

When in range, the receiver is powered by the ping sufficiently to be able to announce its presence to the transmitter, and a transaction begins. The transmitter provides a small amount of power to the newly discovered receiver, so it can tell the transmitter what its power requirements are.

At the completion of this handshake, the transmitter begins providing the requested power. During power transfer, the receiver continuously communicates with the transmitter, actively directing the process. In this way, it is assured that power is only sent when and how it is required by an available and desirous receiver – and in the way that is compatible with the requirements of the receiver. If required, a receiver can actively increase or decrease its power request, and the transmitter will act accordingly. As such, equipment with complex charging requirements can be precisely supported and only the desired amount of power is provided.

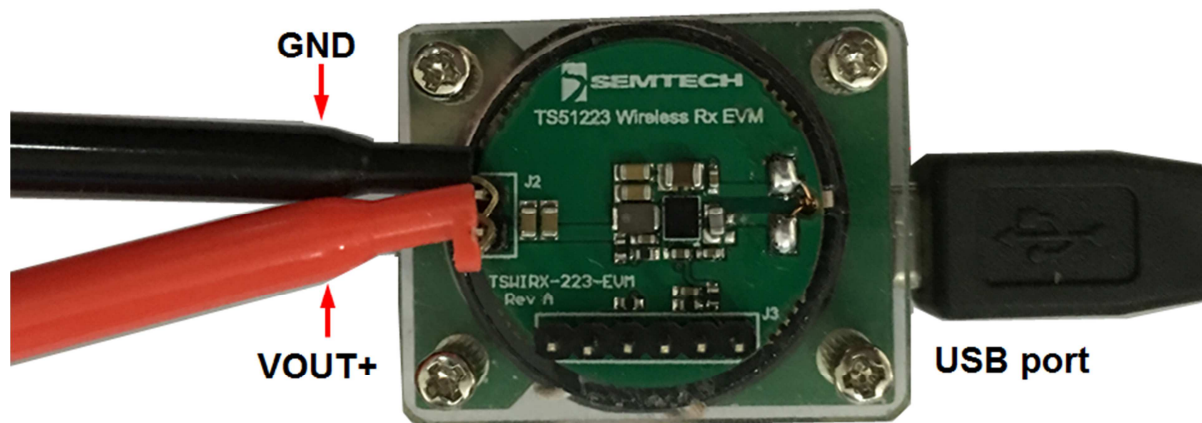

EVM Receiver Tests

A variety of tests can be performed with the use of the TSWITX-G2-EVM/TSWITX-G4-EVM transmitter module.

Connect a USB cable from any USB port capable of driving up to 2 watts (most PCs will suffice) to the USB port on the TSWITX-G2-EVM/TSWITX-G4-EVM. On application of power, its green LED should light, indicating the board is now active.

In order to use the TSWIRX-5V2-EVM as a target receiver, simply place the receiver over the target circle (the 'primary coil' or 'transmitter antenna') on the transmitter EVM module. You can measure 5.2V at J2 connector, indicating power is being received. The EVM's purpose is to receive power; next you can decide what to deliver that power to.

The user has a number of possible options to choose from. The optimal load to select would be a Programmable DC Electronic Load. A 'load box' can easily be set to draw a selected current or power at the turn of a knob, making them very flexible and easy to use in observing power supply operation in general. If a load box is not available, a power resistor decade box is nearly as convenient, as it can easily be set to any desired resistance to simulate a range of load conditions. If need be, a selection of resistors could be used as test loads, though without the ease of modification of the prior options. Be sure the test load is rated for at least the amount of power being tested. Finally, any device that uses a 5 volt input up to 1.25 watt of power can be used as a test load should that be desired.

Whatever load is selected, wires must be run from the VOUT+ and GND pins of the receiver EVM to the selected test load, as per the illustration above. Once the load is added, the receiver EVM can be used to perform a variety of tests.

Connect a DC voltmeter across the VOUT+ and GND pins to monitor the voltage being output to the load, and a DC ammeter in series with the VOUT+ line. Set levels to allow for up to 10 volts and 1 amp to be observed.

With no load selected, place the receiver on the center of the transmitter target circle. Once transmission begins, you should observe approximately 5 volts and 0 amperes on the meters.

Apply a variety of loads to observe performance up to one the watt level. Voltage should remain nearly constant, and current should follow the $P=V*I$ relationship. Experiment with the maximum power that can be drawn before the system reaches its limits and output voltage falls off.

Measure Efficiency

By measuring the power from the receiver's VOUT+ and GND pins in comparison to the power entering the transmitter EVM, you can determine the efficiency of the power transfer through the system.

The diagram below was obtained from the TSWITX-G4-EVM and TSWIRX-5V2-EVM. When measuring efficiency, be sure to remove the jumpers on the receiver and transmitter that enable the status LEDs, as these will affect the measurements.

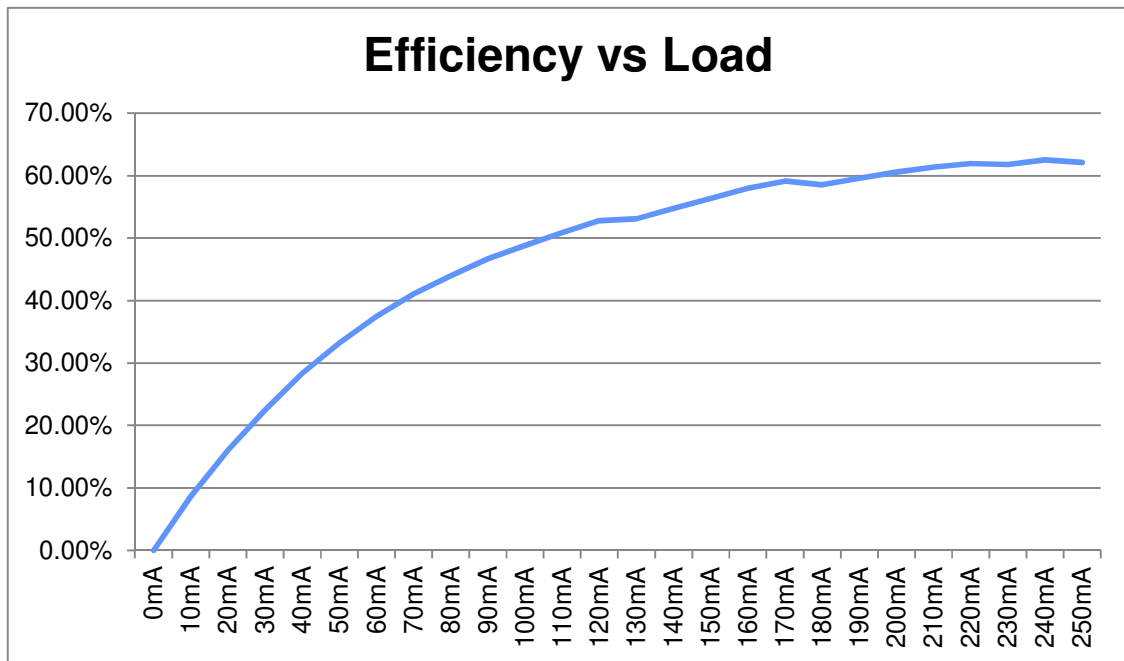

Documentation

The following sections document the hardware design of the TSWIRX-5V2-EVM. This information can be used to better understand the functionality of the design, as well as assist in creating your own hardware solution based on this design

A. Block Diagram

The TSWIRX-5V2-EVM may be divided into a number of sub-blocks as show in the diagram below:

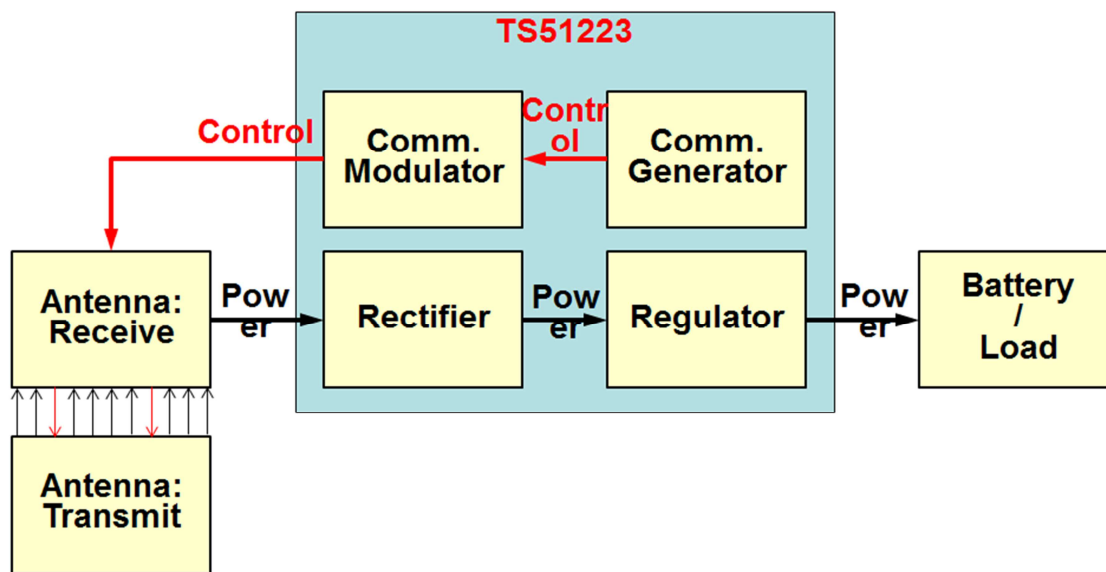

Antenna: Transmit – primary coil providing power to the receiver; part of TSWITX-G2-EVM/TSWITX-G4-EVM

Antenna: Receive – secondary coil in the flux field of the transmit antenna; part of the 1 MHz resonant tank

Rectifier – converts AC voltage from the antenna to positive values; FET based for high efficiency conversion

Regulator - based on the TS51223; converts rectified input to regulated 5v output; includes protection circuitry

Comm. Generator - produces the 'handshake' signal telling the transmitter to provide power

Comm. Modulator — sends the handshake signal to the transmitter

Battery/Load – end equipment to be powered by the wireless receiver

B. Schematic

Below are two copies of the schematic for the TSWIRX-5V2-EVM. The first will be best when viewed on-screen, as it is normally oriented and can be zoomed in on for readability. The second will allow better use in print-out form, as the landscape orientation allows a larger image to be provided. For each, annotation has been added to indicate which part of the block diagram each component is a member of.

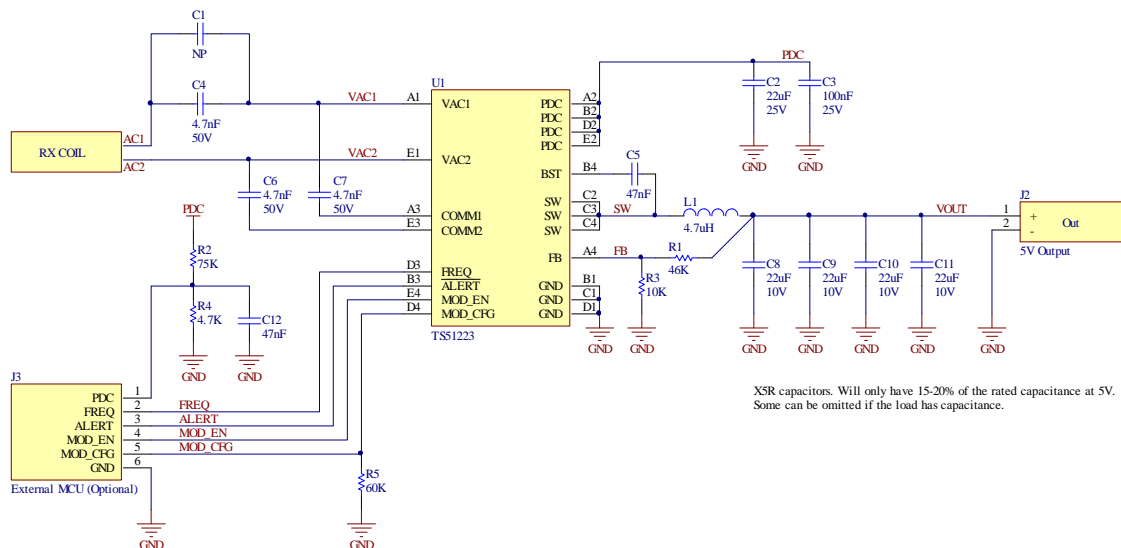

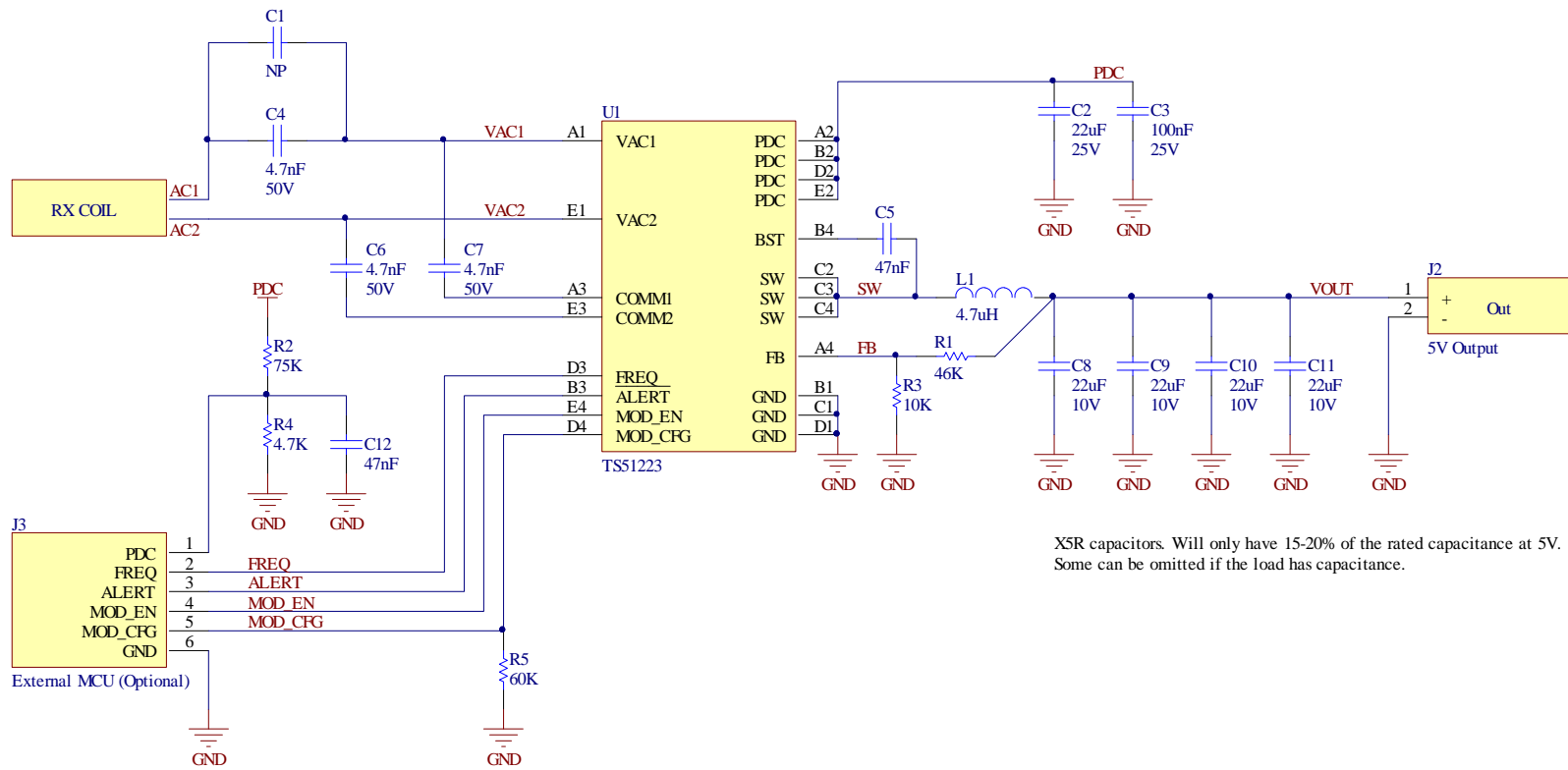

X5R capacitors. Will only have 15-20% of the rated capacitance at 5V. Some can be omitted if the load has capacitance.

C. Bill Of Materials “BOM”

Below is a listing of the parts used in the TSWIRX-5V2-EVM. Note that only a few dozen components were required to implement the complete receiver solution. An excel spreadsheet file with this information is available on the Semtech website as an added convenience.

SN	Designator	Description	Footprint	Manufacturer	ManufacturerCode	Quantity
1	C1	NP	CAPC0402L			1
2	C2	0805 22uF 50V X5R	CAPC0805L	TDK	C2012X5R1E226M125AC	1
3	C3	0402 100nF 50V	CAPC0402L			1
4	C4	0603 4.7nF 50V C0G	CAPC0603L	TDK	C1608C0G1H472J080AA	1
5	C5, C12	0402 47nF 10V	CAPC0402L			2
6	C6, C7	0402 4.7nF 50V	CAPC0402L			2
7	C8, C9, C10, C11	0603 22uF 10V X5R	CAPC0603L	TDK	C1608X5R1A226M080AC	4
8	L1	0805 4.7uH	RESC0805L	TDK	VLS201612CX-4R7M	1
9	R1	0402 46K4	RESC0402L			1
10	R2	0402 75K	RESC0402L			1
11	R3	0402 10K	RESC0402L			1
12	R4	0402 4.7K	RESC0402L			1
13	R5	0402 60K4	RESC0402L			1
14	J2	header 1x2Pin 2.0mm			2pin 2.0mm	1
15	J3	Header 1x6Pin 2.0mm			6 pin 2.0mm	1
16	U1	Wireless Power Receiver	WCSP40P18 0X220-20VN	Semtech	TS51223	1
17	AC1,AC2	Coil		E&E	ES Y31-60150F	1

D. Board Layout

The diagram below shows the locations of the components used in the TSWIRX-5V2-EVM PCB.

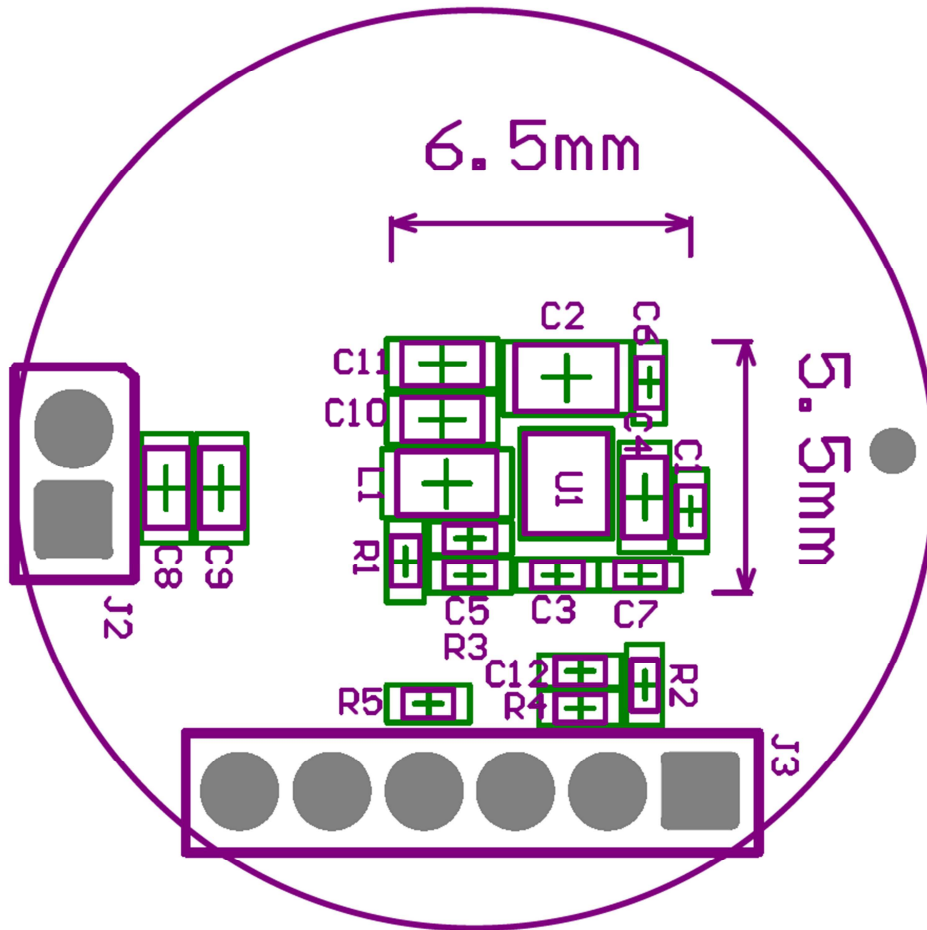

E. Board Layers

The TSWIRX-5V2-EVM PCB is based on a four layer design as shown below. The ground plane in layer two is recommended to reduce noise and signal crosstalk. The EVM placed all components on the top of the board for easier evaluation of the system. End product versions of this design can be made significantly smaller by distributing components on both sides of the board. The Gerber files for this artwork can be downloaded from the Semtech web page.

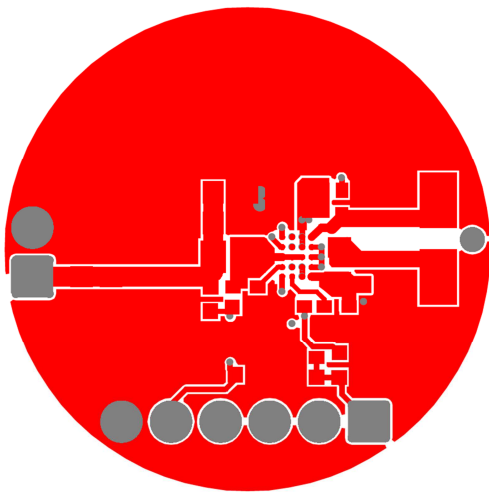

Top Layer

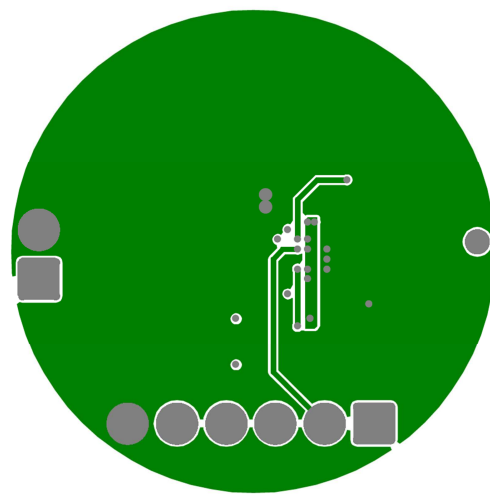

Ground Plane

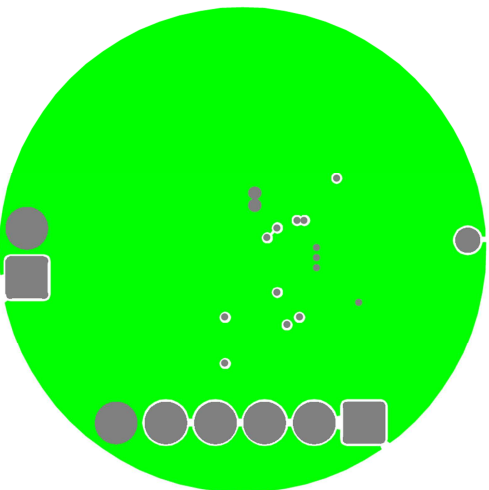

Signal Layer

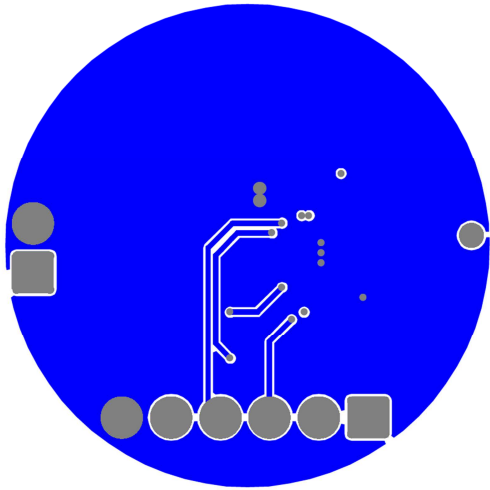

Bottom Layer

FAQs

Q: What output voltage is provided by the TSWIRX-5V2-EVM system?

A: The output is 5 volts, with a maximum power 1.25 watt.

Q: Is the TSWIRX-5V2-EVM compliant with Qi or another wireless transmission standard?

A: These low power wearable solutions are not based on existing standards in order to employ smaller coils and other optimizations that better suit the low power system environment.

Q: Does the EVM part number represent something in particular?

A: Yes. The part number is broken into a prefix, main body, and suffix, separated by dashes. The prefix is comprised of three two letter groupings that each help define the product represented. As such, the part number can be read as follows:

Prefix characters:

1+2 = Company :	TS = Triune/Semtech	
3+4 = Environment :	DM = Dual Mode	WI = Wearable Infrastructure
5+6 = Type :	TX = Transmit	RX = Receive

Mid-section = Device Voltage or Wattage

Suffix = Equipment type:

EVM = Evaluation Module
MOD = Production Module

Thus, the TSWIRX-5V2-EVM is a Wearable Infrastructure, 5 volt Receiver Evaluation Module provided by Semtech.

Q: Does the TSWIRX-5V2-EVM implement Foreign Object Detection (FOD)?

A: FOD detection is an important protection in higher power systems, but in low power wearable infrastructure systems there is no risk of overheating, rendering FOD management unnecessary.

Q: What if my questions weren't answered here?

A: Go to the Semtech website as described on the next page. An updated FAQ for the TSWIRX-5V2-EVM is maintained there and may contain the answers you're looking for. Your local Semtech FAE can also assist in answering your questions.

Next Steps

For more information on Wireless Power, go to the Semtech webpage at:

<https://www.semtech.com/power-management/wireless-charging-ics/>

You may also scan the bar code to the right to go to the above web page:



There you can find the downloadable copies of the schematic, BOM, and board artwork, as well as additional information on how to obtain Semtech wireless power products, from the chip level all the way to complete board modules, as your needs require.



IMPORTANT NOTICE

Information relating to this product and the application or design described herein is believed to be reliable, however such information is provided as a guide only and Semtech assumes no liability for any errors in this document, or for the application or design described herein. Semtech the latest relevant information before placing orders and should verify that such information is current and complete. Semtech reserves the right to make changes to the product or this document at any time without notice. Buyers should obtain warrants performance of its products to the specifications applicable at the time of sale, and all sales are made in accordance with Semtech's standard terms and conditions of sale.

SEMTECH PRODUCTS ARE NOT DESIGNED, INTENDED, AUTHORIZED OR WARRANTED TO BE SUITABLE FOR USE IN LIFE-SUPPORT APPLICATIONS, DEVICES OR SYSTEMS, OR IN NUCLEAR APPLICATIONS IN WHICH THE FAILURE COULD BE REASONABLY EXPECTED TO RESULT IN PERSONAL INJURY, LOSS OF LIFE OR SEVERE PROPERTY OR ENVIRONMENTAL DAMAGE. INCLUSION OF SEMTECH PRODUCTS IN SUCH APPLICATIONS IS UNDERSTOOD TO BE UNDERTAKEN SOLELY AT THE CUSTOMER'S OWN RISK. Should a customer purchase or use Semtech products for any such unauthorized application, the customer shall indemnify and hold Semtech and its officers, employees, subsidiaries, affiliates, and distributors harmless against all claims, costs damages and attorney fees which could arise.

The Semtech name and logo are registered trademarks of the Semtech Corporation. All other trademarks and trade names mentioned may be marks and names of Semtech or their respective companies. Semtech reserves the right to make changes to, or discontinue any products described in this document without further notice. Semtech makes no warranty, representation or guarantee, express or implied, regarding the suitability of its products for any particular purpose. All rights reserved.

© Semtech 2015

Contact Information

Semtech Corporation
200 Flynn Road, Camarillo, CA 93012
Phone: (805) 498-2111, Fax: (805) 498-3804
www.semtech.com