



Chipsmall Limited consists of a professional team with an average of over 10 year of expertise in the distribution of electronic components. Based in Hongkong, we have already established firm and mutual-benefit business relationships with customers from,Europe,America and south Asia,supplying obsolete and hard-to-find components to meet their specific needs.

With the principle of "Quality Parts,Customers Priority,Honest Operation,and Considerate Service",our business mainly focus on the distribution of electronic components. Line cards we deal with include Microchip,ALPS,ROHM,Xilinx,Pulse,ON,Everlight and Freescale. Main products comprise IC,Modules,Potentiometer,IC Socket,Relay,Connector.Our parts cover such applications as commercial,industrial, and automotives areas.

We are looking forward to setting up business relationship with you and hope to provide you with the best service and solution. Let us make a better world for our industry!



## Contact us

Tel: +86-755-8981 8866 Fax: +86-755-8427 6832

Email & Skype: info@chipsmall.com Web: www.chipsmall.com

Address: A1208, Overseas Decoration Building, #122 Zhenhua RD., Futian, Shenzhen, China





**Wireless Power**  
**4.2V LiPo 100mA~400mA**

**WIRELESS CHARGING**

---

## **User Guide**

# **LinkCharge™ LP Series Wireless Charging**

---

# Introduction

The Semtech TSWIRX-LI2-EVM is an evaluation platform for the test and experimentation of a wireless charging receiver based on the Semtech TS51224 fully-integrated Wireless Power Receiver and battery charger for low-power IC. This evaluation module, in conjunction with its compatible transmitter TSWITX-G4-EVM, provides a complete system solution for low power transmission, receiving and charging for wearable devices.

## Objectives

The objective of this User Guide is to provide a fast, easy and thorough method to experiment with and evaluate the Semtech solutions for wireless charging systems. Sufficient information is provided to support the engineer in all aspects of adding wireless charging support to their products. Semtech offers a range of solutions to meet the needs of a wide range of system developers. Developers are provided with all the information on how this EVM was built as a starting point for their own designs using the TS51224.

## Features

- 4.2V output / 100mA~400mA charge current

Please make sure to download the latest software visit [www.semtech.com/wireless-charging](http://www.semtech.com/wireless-charging) to download the latest EVM software for your evaluation board

## Table of Contents

<i>Product Description</i> .....	3
<i>Standard Use</i> .....	4
<i>Documentation</i> .....	5
A. Block Diagram.....	5
B. Schematic.....	5
C. Bill Of Materials "BOM" .....	7
D. Thermal.....	8
E. Board Layout.....	9
F. Board Layers.....	9
<i>FAQs</i> .....	12
<i>Next Steps</i> .....	13

# Wireless Charging Concepts

Wireless power transfer is, essentially, a transformer. Power is provided to a primary coil which produces an electromagnetic (EM) field. In this field, a secondary coil is placed. The EM field induces a current into the secondary coil, providing power to whatever it is connected to.

However, unlike a conventional power transformer that operates at line frequencies and requires an iron core for efficiency, low power wireless power systems for wearable devices have been designed to operate in the 1 MHz range, and thus can perform efficiently with an air core. As such, the primary and secondary windings, if closely spaced, can be in separate devices, the primary being part of a transmitter and the secondary within a receiver. This implementation can also be described as a radio broadcast process, and as such, these transformer coils can also be seen as antennas with equal validity, and the two terms will be used interchangeably in this text..

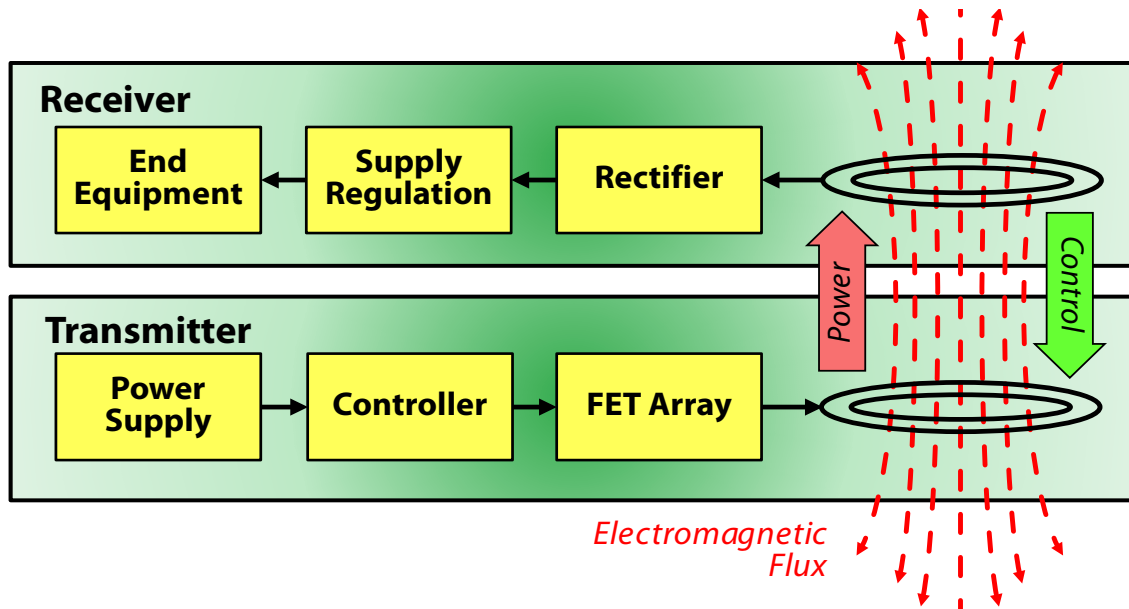

Wireless power systems differ in another major aspect from conventional transformers, in that they are intelligently managed. A transmitter will only provide power when a receiver is present, and only produce the amount of power requested by the receiver. In addition, the system is capable of recognizing when the electromagnetic field has been interrupted by an unintended element, a 'foreign object', and will shut down the transfer to prevent any significant amount of power being absorbed by anything but a proper receiver. The intelligent management of the wireless power transmission process is achieved through the programming of the TS80000, which first searches for a receiver. Once found, the receiver informs the transmitter of its power requirements, and transmission begins. The system then verifies the right amount of power is being sent, and that none is being lost to foreign objects. The receiver will continually provide ongoing requests for power to maintain the transaction. If the requests cease, the transaction terminates. Via this protocol, even complex charging patterns can be supported, as the transmitter can provide varying amounts of power at different times, as requested by the receiver. Should the receiver require no further power, such as when a battery charge is completed, it can request no further power be sent, and the transmitter will reduce its output accordingly.

Wireless power systems have been broken into three power categories. "Wearable" devices, such as headsets, wrist-band devices, medical sensors etc - operate in the low power range, up to 3 watts. Medium power devices, in the 5- to 15-watt range, include handheld devices, such as cell phones, tablets, and medical electronics. High power systems support devices such as power tools, radio controlled ("RC") devices such as drones, and other equipment requiring 15 to 100 watts of power.

---

## Product Description

The TSWIRX-LI2-EVM Evaluation Module is coupled with its compatible transmitter module, the Semtec WITX-G4-EVM, to form a complete wireless power transmission system, to directly charge a single cell Li-ion battery for approximately 250mA of charging current.

Those who wish to develop their own board, or integrate this functionality into an existing system can use the EVM as a starting point for their design, as it demonstrates a working model from which to proceed.

Toward this end, all documentation for the EVM is provided to make the process as efficient as possible.

The key technology in the EVM is the Semtech TS51224, which is a fully-integrated wireless power receiver and battery charger for low-power, wearable applications that require a low-cost and space-saving solution. The TS51224 can operate by itself as a single-chip wireless power receiver in proprietary applications. It can also operate in conjunction with a wireless power controller or an application microcontroller to support the Qi, PMA or A4WP wireless charging standards as well as proprietary standards up to 2W combined system/battery power.

Once the system is set up and working, a selection of tests and activities will be described that the evaluator can choose to perform.

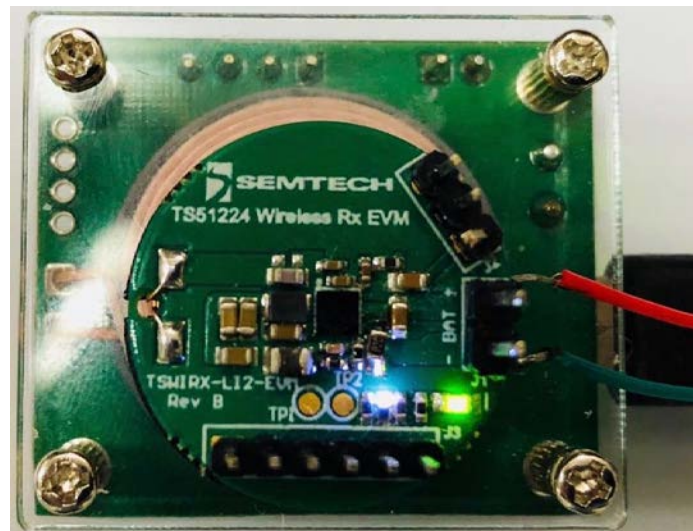

### LED Behavior

The green LED on EVM let the user know the status of charge voltage. When power is applied, the receiver initializes as indicated by the green LED lighting. When a battery or a charge current occurs, the white LED will lighting, once the charge ends, white LED will turn OFF.

---

## Standard Use

The TSWIRX-LI2-EVM is easy to set up and use. Connect a USB cable from any USB port capable of driving up to 2 watts (most PCs will suffice) to the USB port on the TSWITX-G4-EVM. On application of power, its green LED should light, indicating the board is now active.

At this point, the transmitter EVM is ready to transmit power. A few times each second, the transmitter emits a 'ping' of energy in search of a compliant receiver in range.

When in range, the receiver is powered by the ping sufficiently to be able to announce its presence to the transmitter, and a transaction begins. The transmitter provides a small amount of power to the newly discovered receiver, so it can tell the transmitter what its power requirements are.

At the completion of this handshake, the transmitter begins providing the requested power. During power transfer, the receiver continuously communicates with the transmitter, actively directing the process. In this way, it is assured that power is only sent when and how it is required by an available and desirous receiver – and in the way that is compatible with the requirements of the receiver. If required, a receiver can actively increase or decrease its power request, and the transmitter will act accordingly. As such equipment with complex charging requirements can be precisely supported and only the desired amount of power is provided.

### EVM Receiver Tests

A variety of tests can be performed with the use of the TSWITX-G4-EVM transmitter module. Connect a USB cable from any USB port capable of driving up to 2 watts (most PCs will suffice) to the USB port on the TSWITX-G4-EVM. On application of power, its green LED should light, indicating the board is now active.

In order to use the TSWIRX-LI2-EVM as a target receiver, simply place the receiver over the target circle (the 'primary coil' or 'transmitter antenna') on the transmitter EVM module, and then connect a battery to the J1 of receiver. Connect a DC voltmeter across the SYSOUT and GND pins to monitor the voltage, and a DC ammeter in series with the J1 line to monitor the charging current. Set levels to allow for up to 10 volts and 1 amp to be observed.

The LED should be light white when receiver placed on the active transmitter, which indicate SYSOUT put voltage is normal, once the charge starting the white LED will be on.

The programmed CC charge current can be set through R7 ( $I = V_{ISP}/R7$ ) showing sch, for example 1C is 175mA, then

$$R_7 = \frac{V_{ISP}}{I_{CC}} = \frac{25}{175} = 0.143\Omega$$

0.15Ω resistor can be used.

**$V_{ISP}$  is 25mV.**

The battery termination voltage is set by placing a resistor to ground on TOP\_SET pin. The IC will provide a 20μA DC output current. The termination voltage will be set according to the following equation.

$$V_{TERM} = 4.1V + 20\mu A * (R_{TOP\_SET} / 10)$$

---

## Documentation

The following sections document the hardware design of the TSWIRX-LI-EVM. This information can be used to better understand the functionality of the design, as well as assist in creating your own hardware solution based on this design.

### A. Block Diagram

The TSWIRX-LI2-EVM may be divided into a number of sub-blocks as show in the diagram below:

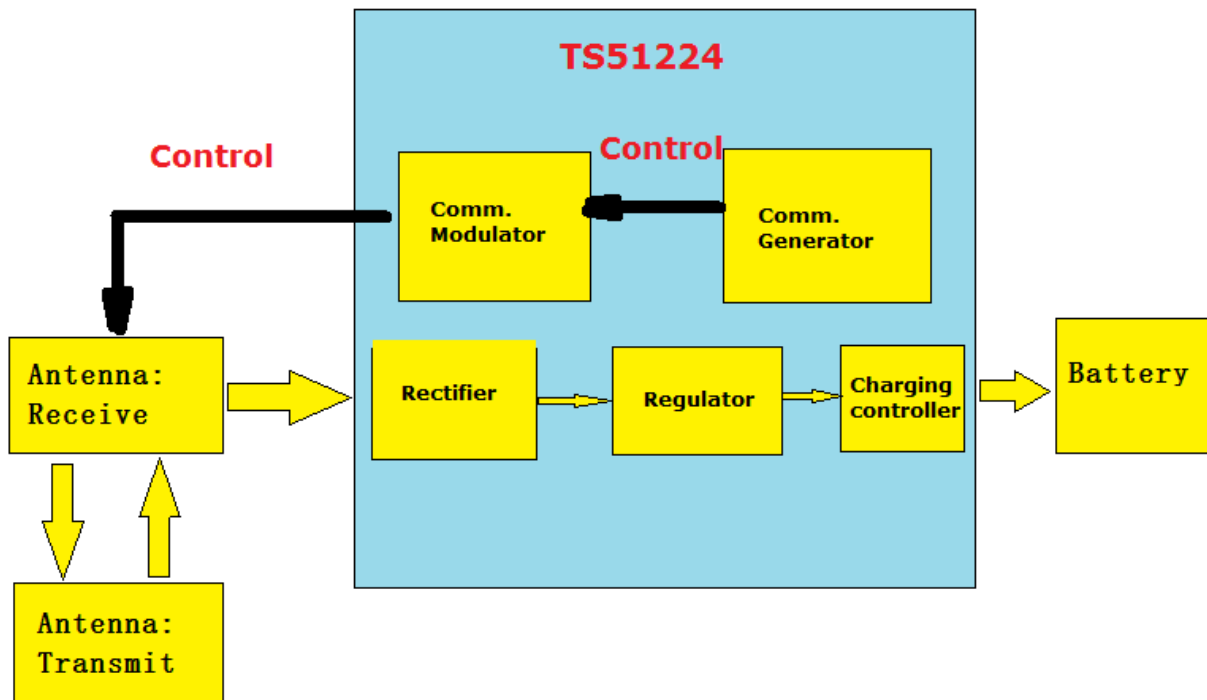

**Antenna: Transmit** – primary coil providing power to the receiver; part of TSWITX-G4-EVM

**Antenna: Receive** – secondary coil in the flux field of the transmit antenna; part of the 1 MHz resonant tank

**Rectifier** – converts AC voltage from the antenna to positive values; FET based for high efficiency conversion

**Regulator** - based on the TS51224; converts rectified input to regulated 5v output; includes protection circuitry

**Comm. Generator** - produces the 'handshake' signal telling the transmitter to provide power

**Comm. Modulator** — sends the handshake signal to the transmitter

**Battery/Load** – end equipment to be powered by the wireless receiver

### B. Schematic

Below is the schematic for the TSWIRX-LI2-EVM.

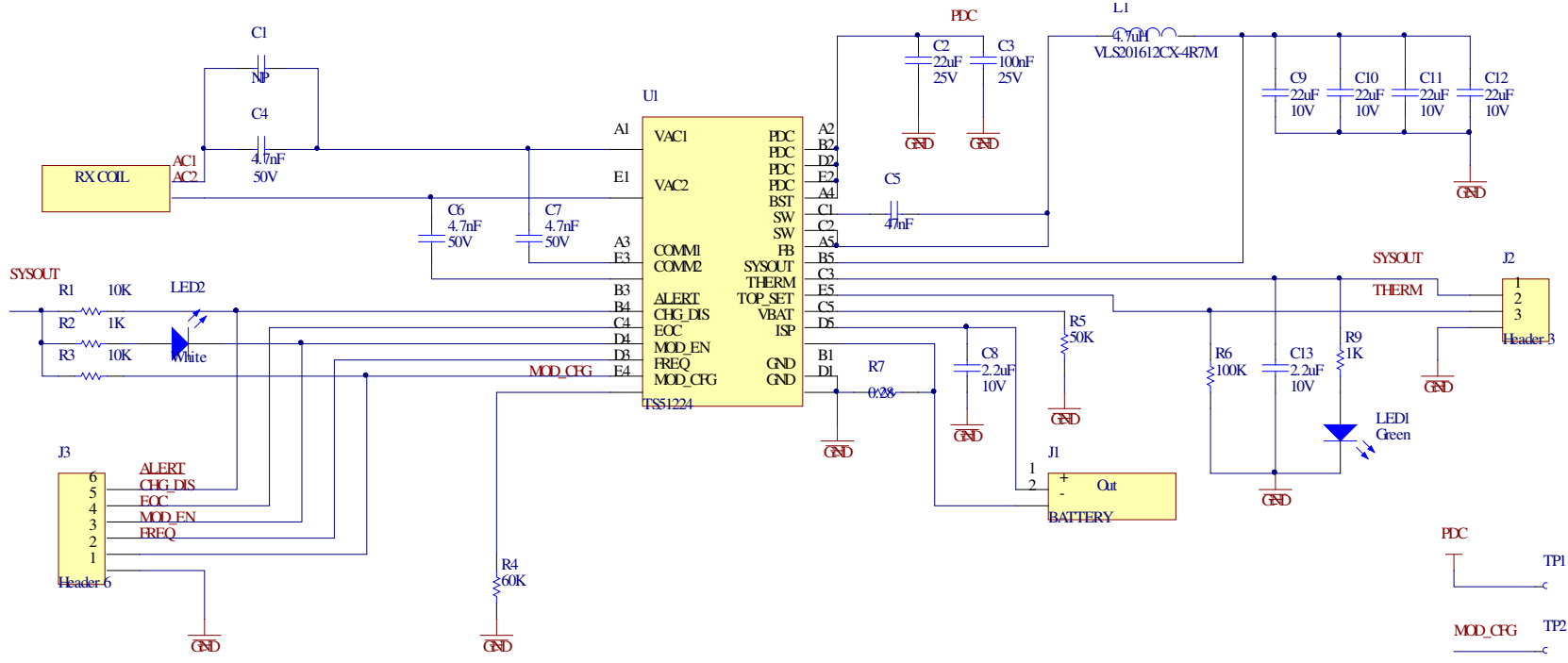



## C. Bill Of Materials “BOM”

Below is a listing of the parts used in the TSDMTX-19V3-EVM. An excel spreadsheet file with this information is available on the Semtech website as an added convenience.

Item	Designator	Qt.	Description	Part Number	MFR.
1	C2	1	0805 22uF 25V X5R		
2	C3	1	0402 100nF 25V		
3	C4	1	0603 4.7nF 50V C0G		
4	C5	1	0402 47nF 10V		
5	C6, C7	2	0402 4.7nF 50V		
6	C8, C13	2	0603 2.2uF 10V X7R		
7	C9, C10, C11, C12	4	0603 22uF 10V X5R		
8	L1	1	4.7uH	VLS201612CX-4R7M	TDK
9	LED1	1	LED 0603 Green		
10	LED2	1	LED 0603 White		
11	R1, R3	2	0402 10K		
12	R4	1	0402 47K(or 60K4)		
13	R5	1	0402 50K(or 49K9)		
14	R6	1	0402 100K		
15	R7	1	0603 0R28		
16	R9, R2	2	0402 1K		
17	U1	1	Wireless Power Receiver	TS51224	Setmech
18	Coil	1	12.3±15%uH DCR 760mΩ Max.	Y31-60150F	E&E
19	Acrylic	1	Acrylic 14mm × 10mm × 3mm		
20	J2	1	Header 1×3pins, 2.00mm, male, TH		
21	J3	1	Header 1×6pins, 2.00mm, male, TH		
22	J1	1	Header 1×2pins, 2.54mm, male, TH		
23	C1	1	NP		
24	PCB	1	TSWIRX-LI2-EVM Rev.B		

### Rx coil Specifications:

Vendor	Part Number	Inductance	DCR (Max.)	Dimension (Max.)
E&E	Y31-60150F	12.3±15%uH	760mΩ	Ø22.5mm

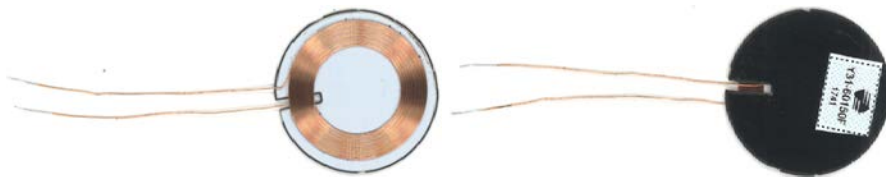

Coil size  $\varnothing 22.5\text{mm}$

Attention:

1. Resonance capacitors (C1,C4) should be COG capacitor, it should significantly decrease the temperature;

**Transmitter information:**

**TSWITX-G4-EVM (coil TDK WT252512-8F2-SM)**

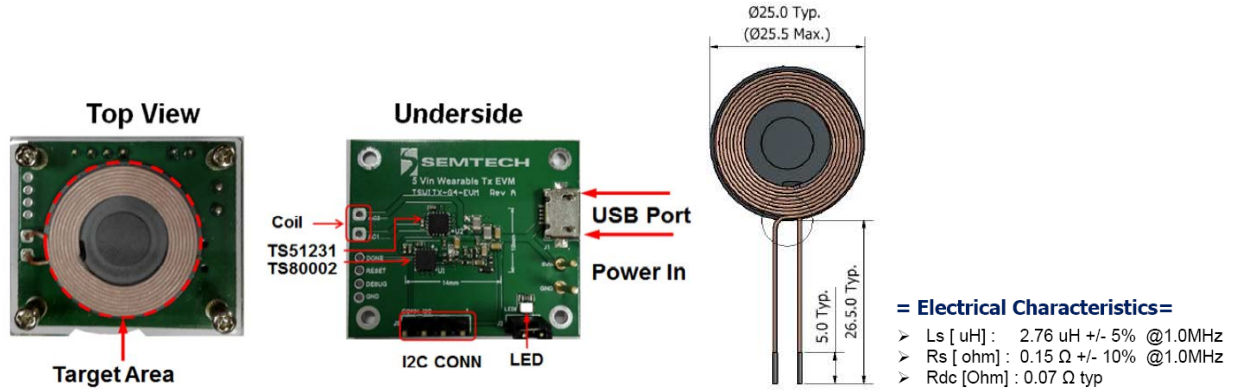

The other 2 kinds of Transmitter can be chosen:

**TSWITX-12V-EVM (Coil E&E Y31-60181F)**

**ELECTRICAL SPECIFICATION @25°C**

PARAMETERS	UNIT	LIMIT
Inductance @ 100KHz, 1.0Vrms	$\mu\text{H}$	$6.3 \pm 10\%$
DCR	$\text{m}\Omega$	85 Max
Q Factor @ 100KHz, 1.0Vrms	--	40 Typ
$R_S$ (AC Resistance)@ 100KHz, 1.0Vrms	$\text{m}\Omega$	95 Max

**TSWITX-5V-2RX-EVM (coil TDK WT252512-8F2-SM or WE 760308102308)**

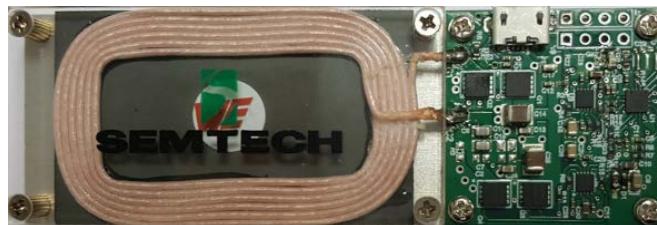

**D. Thermal**

The gap between Tx and Rx is 6mm, operation temperature: 26.5°C.

R7=0.15Ω 1C charge current is 175mA, 30min.

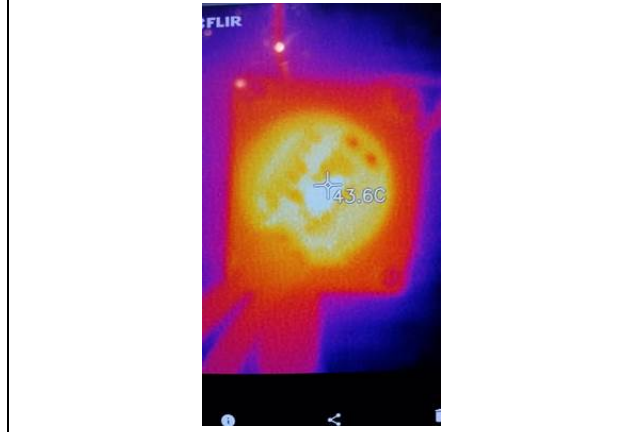

## E. Board Layout

The diagram below shows the locations of the components used in the TSWIRX-LI2-EVM PCB.

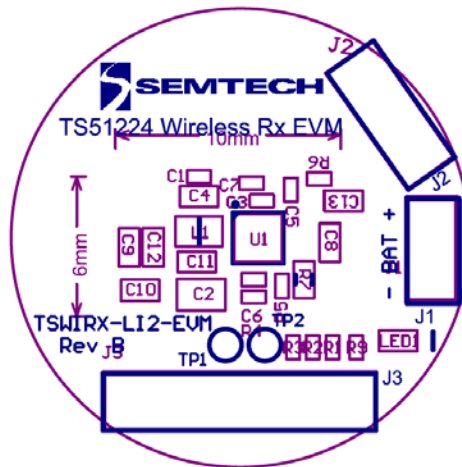

## F. Board Layers

The TSWIRX-LI2-EVM PCB is based on a four layer design as shown below. The ground plane in layer two is recommended to reduce noise and signal crosstalk. The EVM placed all components on the top of the board for easier evaluation of the system. End product versions of this design can be made significantly smaller by distributing components on both sides of the board. The Gerber files for this artwork can be downloaded from the Semtech web page.

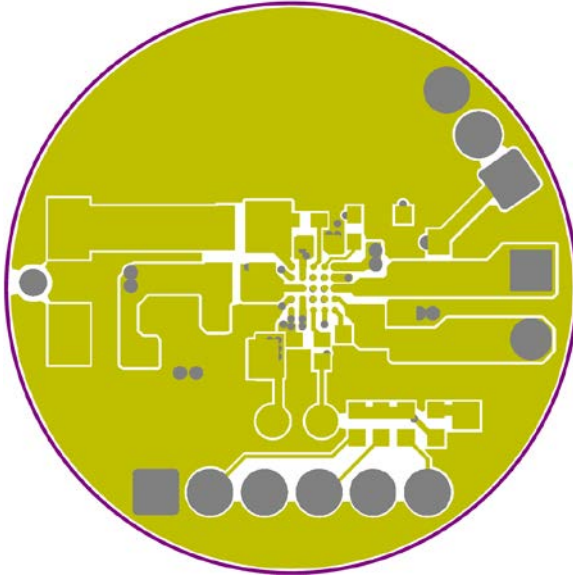

Top Layer

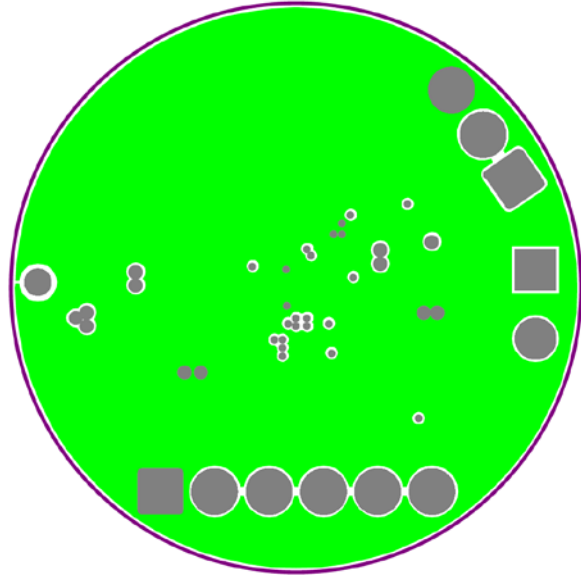

Ground Plane

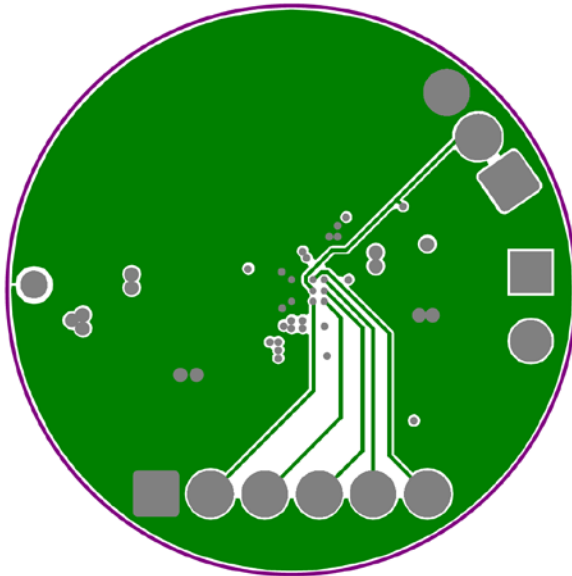

Signal Layer

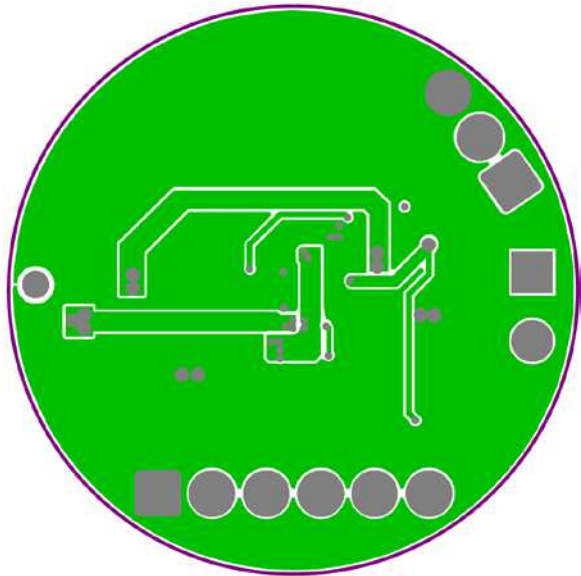

Bottom Layer

### Measure Efficiency

By measuring the power from the receiver's VOUT+(SYSOUT) and GND pins in comparison to the power entering the transmitter EVM, you can determine the efficiency of the power transfer through the system. For the EVMs used here, the diagram below demonstrates that efficiency is a function of output current, and runs about 60% at higher power levels, assuring good efficiency and minimal heat dissipation concerns.

Tx is Semtech TSWITX-G4-EVM.

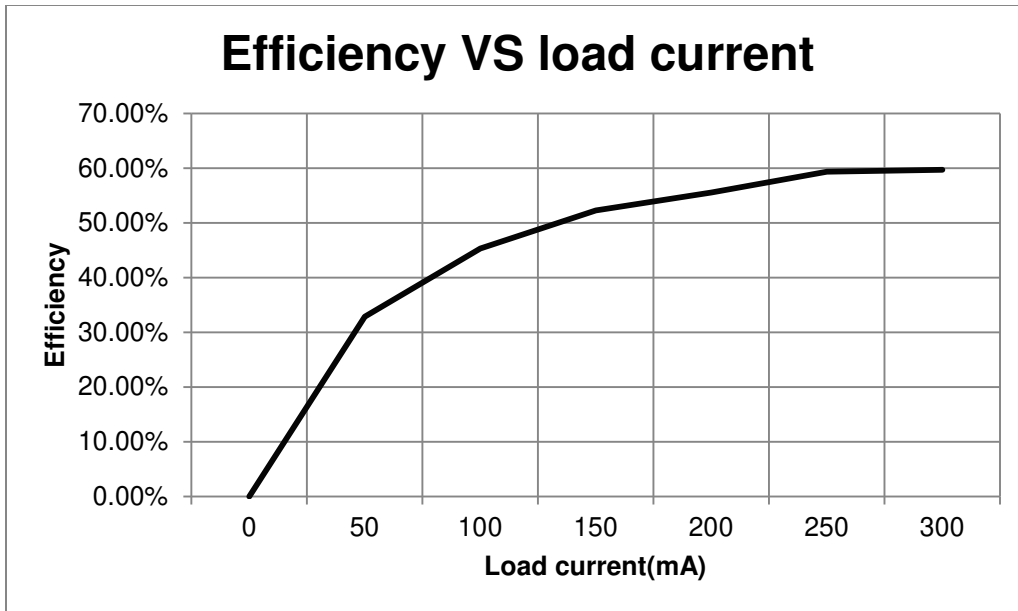

---

## FAQs

Q: What output voltage is provided by the TSWIRX-LI2-EVM system?

A: It depends on which transimitor is being used. For the TSWITX-G4-EVM, the output would be 4.2 volts, at up to 500mA charge current.

Q: Does the EVM part number represent something in particular?

A: Yes. The part number is broken into a prefix, main body, and suffix, separated by dashes. The prefix is comprised of three two letter groupings that each help define the product represented. As such, the part number can be read as follows:

### Prefix characters:

1+2 = Company :	TS = Triune/Semtech	
3+4 = Environment :	DM = Dual Mode	WI = Wearable Infrastructure
5+6 = Type :	TX = Transmit	RX = Receive

Mid-section = Device Voltage and/or Wattage

### Suffix = Equipment type:

EVM = Evaluation Module  
MOD = Production Module

Therefore, the TSWIRX-LI2-EVM is a Wearable infrastructure, Li charger receiver Evaluation Module provided by Semtech.

Q: What if my questions weren't answered here?

A: Go to the Semtech website as described on the next page. An updated FAQ for the TSWIRX-LI2-EVM is maintained there and may contain the answers you're looking for. Your local Semtech FAE can also assist in answering your questions.

---

## Next Steps

For more information on Wireless Power, go to the Semtech webpage at:

**<https://www.semtech.com/power-management/wireless-charging-ics/>**

You may also scan the bar code to the right to go to the above web page:



There you can find the downloadable copies of the schematic, BOM, and board artwork, as well as additional information on how to obtain Semtech wireless power products, from the chip level all the way to complete board modules, as your needs require.



---

#### **IMPORTANT NOTICE**

Information relating to this product and the application or design described herein is believed to be reliable, however such information is provided as a guide only and Semtech assumes no liability for any errors in this document, or for the application or design described herein. Semtech the latest relevant information before placing orders and should verify that such information is current and complete. Semtech reserves the right to make changes to the product or this document at any time without notice. Buyers should obtain warrants performance of its products to the specifications applicable at the time of sale, and all sales are made in accordance with Semtech's standard terms and conditions of sale.

SEMTECH PRODUCTS ARE NOT DESIGNED, INTENDED, AUTHORIZED OR WARRANTED TO BE SUITABLE FOR USE IN LIFE-SUPPORT APPLICATIONS, DEVICES OR SYSTEMS, OR IN NUCLEAR APPLICATIONS IN WHICH THE FAILURE COULD BE REASONABLY EXPECTED TO RESULT IN PERSONAL INJURY, LOSS OF LIFE OR SEVERE PROPERTY OR ENVIRONMENTAL DAMAGE. INCLUSION OF SEMTECH PRODUCTS IN SUCH APPLICATIONS IS UNDERSTOOD TO BE UNDERTAKEN SOLELY AT THE CUSTOMER'S OWN RISK. Should a customer purchase or use Semtech products for any such unauthorized application, the customer shall indemnify and hold Semtech and its officers, employees, subsidiaries, affiliates, and distributors harmless against all claims, costs damages and attorney fees which could arise.

The Semtech name and logo are registered trademarks of the Semtech Corporation. All other trademarks and trade names mentioned may be marks and names of Semtech or their respective companies. Semtech reserves the right to make changes to, or discontinue any products described in this document without further notice. Semtech makes no warranty, representation or guarantee, express or implied, regarding the suitability of its products for any particular purpose. All rights reserved.

© Semtech 2015

---

## **Contact Information**

**Semtech Corporation**  
200 Flynn Road, Camarillo, CA 93012  
Phone: (805) 498-2111, Fax: (805) 498-3804  
[www.semtech.com](http://www.semtech.com)