



Chipsmall Limited consists of a professional team with an average of over 10 year of expertise in the distribution of electronic components. Based in Hongkong, we have already established firm and mutual-benefit business relationships with customers from,Europe,America and south Asia,supplying obsolete and hard-to-find components to meet their specific needs.

With the principle of “Quality Parts,Customers Priority,Honest Operation,and Considerate Service”,our business mainly focus on the distribution of electronic components. Line cards we deal with include Microchip,ALPS,ROHM,Xilinx,Pulse,ON,Everlight and Freescale. Main products comprise IC,Modules,Potentiometer,IC Socket,Relay,Connector.Our parts cover such applications as commercial,industrial, and automotives areas.

We are looking forward to setting up business relationship with you and hope to provide you with the best service and solution. Let us make a better world for our industry!



Contact us

Tel: +86-755-8981 8866 Fax: +86-755-8427 6832

Email & Skype: info@chipsmall.com Web: www.chipsmall.com

Address: A1208, Overseas Decoration Building, #122 Zhenhua RD., Futian, Shenzhen, China



REV. Status

REVISION -
11/15/95 TS

REVISION A
ADDED DIM
1(0.04)NOMINAL
02/25/97 TS

HOLDING COIL DESIGNED TO OPERATE AT 1 KHz, 100mADC

A. Electrical Specifications (@ 25 ° C)

1. DC Resistance;
180Ω ±15%
2. Inductance;
1.3 Hy +50%, -10% @ 1 KHz, 1 Vrms and 100mADC
2.0 Hy +50%, -10% @ 1 KHz, 1 Vrms and 60 mADC
3. Dielectric Strength;
1.5 KVrms, 1 minute, Coil to Core

B. Marking; TTC-119, TAMURA, T4415, MICROTRAN, date code and country of origin

D. Schematic Diagram

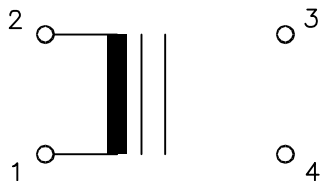

MICROTRAN and T4415

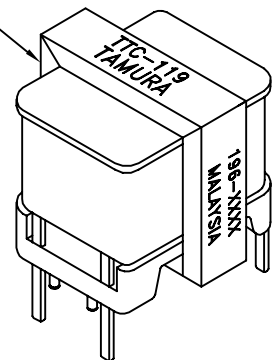

E. Mechanical Specifications

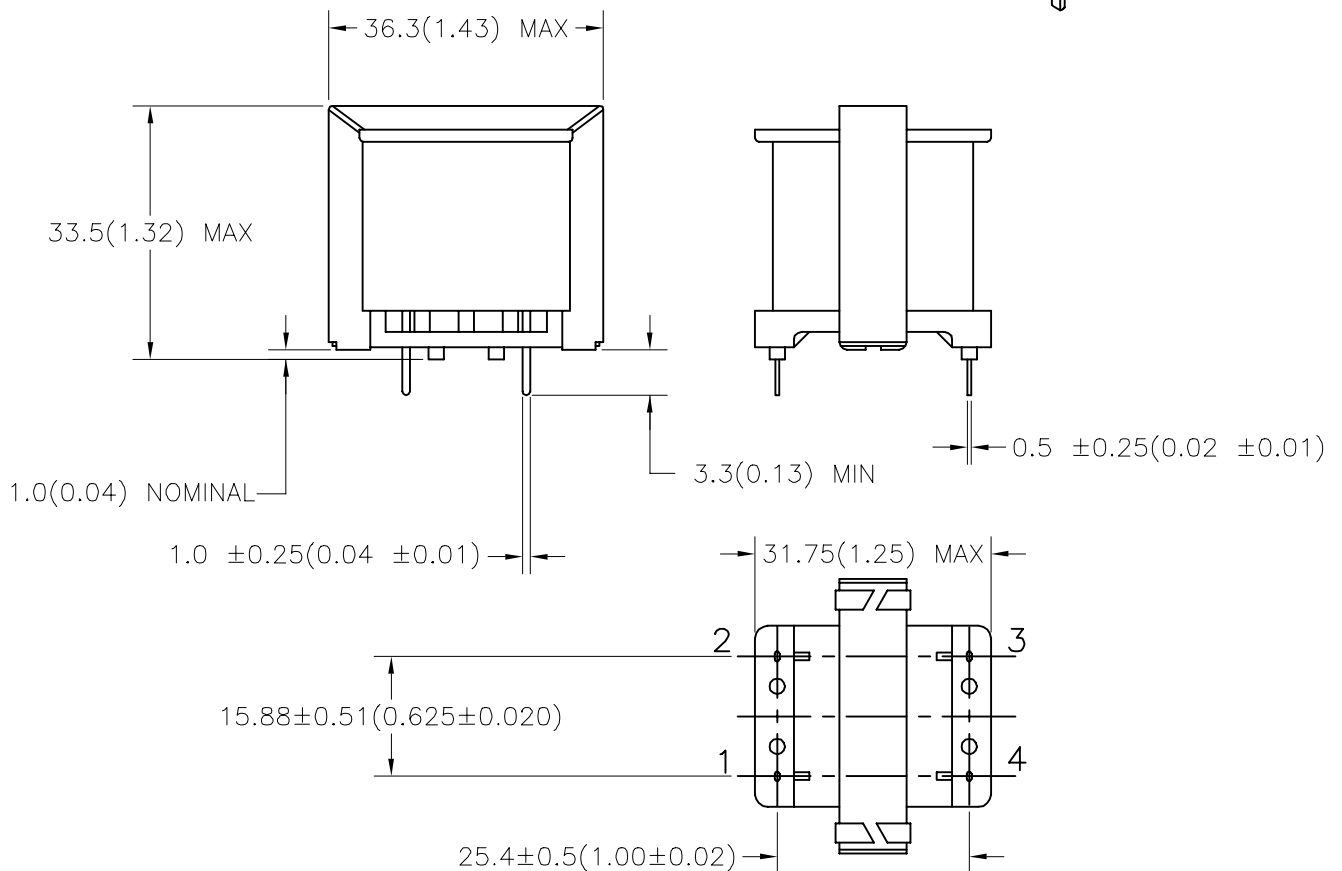

TOLERANCES (mm)

≤ 4	± 0.2
4 ≤ 20	± 0.3
20 ≤ 50	± 0.4

PREPARED BY:

K. Brennan

ENGINEER:

DWG CONTROL NO. P-A1-11463
ACAD\TTC\A1114631.DWG

T. Shiozawa

QUALITY CONTROL:

CONTENTS OF THIS DRAWING ARE SUBJECT TO CHANGE WITHOUT PRIOR NOTICE

D. Kelley

APPROVED:

D. Kelley

REV

A

HOLDING
COIL

TAMURA CORPORATION OF AMERICA

43352 BUSINESS PARK DRIVE, TEMECULA, CA. 92590-6624
(909) 699-1270 FAX 9096769482

TTC-119

MODEL SPECIFICATION

DIM: mm(In) SCL: 1/1 SH: 1 OF 1

PROPRIETARY NOTICE: THIS DRAWING PRINT OR DOCUMENT AND SUBJECT MATTER DISCLOSED HEREIN ARE PROPRIETARY ITEMS TO WHICH TAMURA RETAINS THE EXCLUSIVE RIGHT OF DISSEMINATION, REPRODUCTION, MANUFACTURE AND SALE. THIS DRAWING, PRINT OR DOCUMENT IS SUBMITTED IN CONFIDENCE FOR CONSIDERATION BY THE RECIPIENT ALONE UNLESS PERMISSION FOR FURTHER DISCLOSURE IS EXPRESSLY GRANTED IN WRITING.

MODEL NUMBER

TTC-119