



Chipsmall Limited consists of a professional team with an average of over 10 year of expertise in the distribution of electronic components. Based in Hongkong, we have already established firm and mutual-benefit business relationships with customers from,Europe,America and south Asia,supplying obsolete and hard-to-find components to meet their specific needs.

With the principle of “Quality Parts,Customers Priority,Honest Operation,and Considerate Service”,our business mainly focus on the distribution of electronic components. Line cards we deal with include Microchip,ALPS,ROHM,Xilinx,Pulse,ON,Everlight and Freescale. Main products comprise IC,Modules,Potentiometer,IC Socket,Relay,Connector.Our parts cover such applications as commercial,industrial, and automotives areas.

We are looking forward to setting up business relationship with you and hope to provide you with the best service and solution. Let us make a better world for our industry!



Contact us

Tel: +86-755-8981 8866 Fax: +86-755-8427 6832

Email & Skype: info@chipsmall.com Web: www.chipsmall.com

Address: A1208, Overseas Decoration Building, #122 Zhenhua RD., Futian, Shenzhen, China



A. Electrical Specifications (@ 25°C)

1. Primary (Line Side) Impedance; 135Ω
2. Secondary (IC Side) Impedance; 32Ω
3. Longitudinal Balance; 50dB MIN @ 30KHz to 300KHz, 0dBm (Per ITU method pin 7 grounded)
4. Insertion Loss; 0.65dB MAX @ 30KHz to 580KHz, 0dBm
5. Return Loss; 16dB MIN @ 40KHz to 300KHz, 0dBm
6. Primary Open Circuit Inductance; 2.0mH ±10% @ 10KHz, 0.1Vrms Measured (1-5) with 2 and 4 shorted
7. Leakage Inductance; 6.5μH MAX @ 100KHz, 0.2Vrms Measured (1-5) with 4 & 2, and 9 & 7 shorted
8. DC Current; 160mA
9. Total Harmonic Distortion; -70dB MAX @ 10KHz, 5Vrms
10. DC Resistance; (1-4)=1.60Ω MAX
(2-5)=1.60Ω MAX
(7-9)=1.15Ω MAX
11. Turns Ratio;(7-9):(1-5)=1:2.00±2% with 2 & 4 shorted
12. Dielectric Strength; 1875Vrms 1 second @ Pri to Sec

B. Marking; TTC-4093, TAMURA, date code and country of origin

C. Safety: Complies with UL1950 3rd Edition, UL60950

D. Schematic;

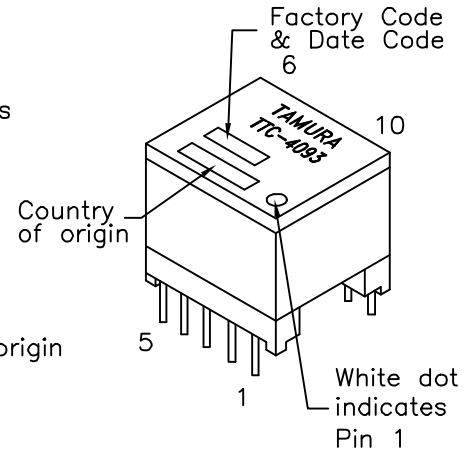
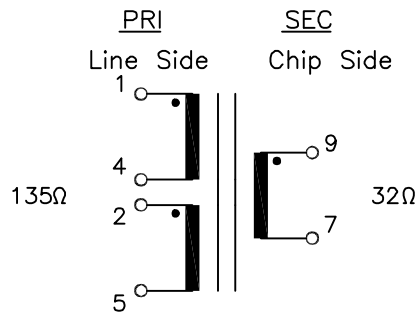

E. Mechanical Specifications

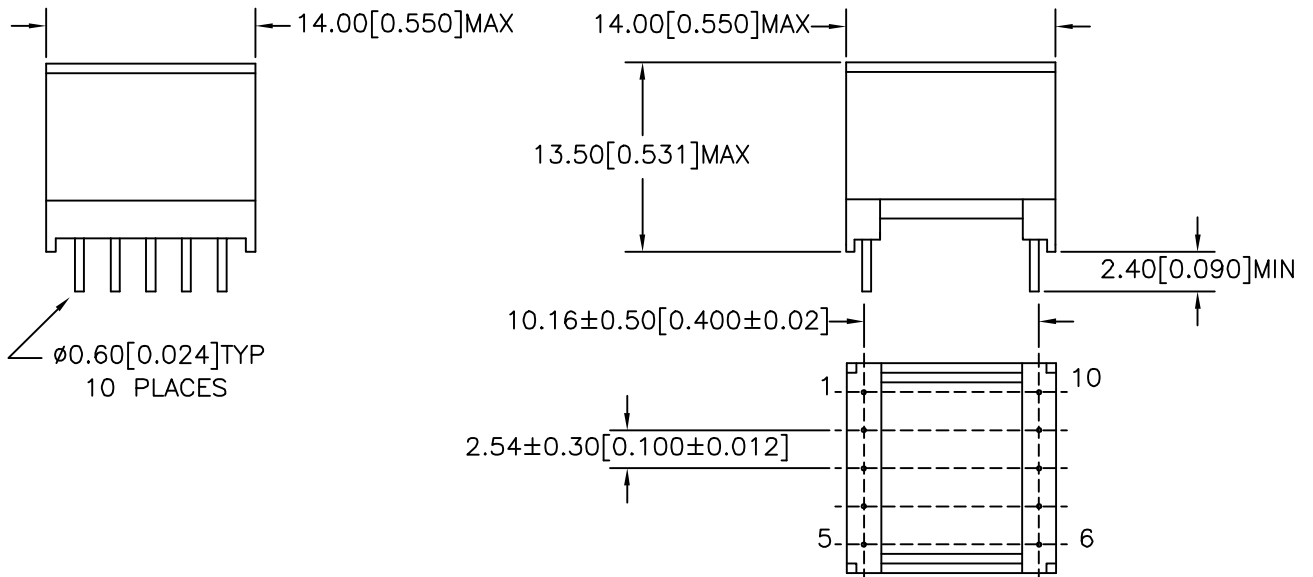

PREPARED BY:

D. Rund

ENGINEER:

M. Pitchai

QUALITY CONTROL:

D. Kelley

APPROVED:

J. Coleman

DWG CONTROL NO.
P-A1-12807
ACAD\TTC\A1128071.DWG

REV
PRE

HDSL
TRANSFORMER

TAMURA CORPORATION OF AMERICA
43352 BUSINESS PARK DRIVE, TEMECULA, CA. 92590-6624
(909) 699-1270 FAX 9096769482

TTC-4093

MODEL SPECIFICATION

DIM: mm(In) SCL: 2/1 SH: 1 OF 1

PROPRIETARY NOTICE: THIS DRAWING PRINT OR DOCUMENT AND SUBJECT MATTER DISCLOSED HEREIN ARE PROPRIETARY ITEMS TO WHICH TAMURA RETAINS THE EXCLUSIVE RIGHT OF DISSEMINATION, REPRODUCTION, MANUFACTURE AND SALE. THIS DRAWING, PRINT OR DOCUMENT IS SUBMITTED IN CONFIDENCE FOR CONSIDERATION BY THE RECIPIENT ALONE UNLESS PERMISSION FOR FURTHER DISCLOSURE IS EXPRESSLY GRANTED IN WRITING.