



Chipsmall Limited consists of a professional team with an average of over 10 year of expertise in the distribution of electronic components. Based in Hongkong, we have already established firm and mutual-benefit business relationships with customers from,Europe,America and south Asia,supplying obsolete and hard-to-find components to meet their specific needs.

With the principle of “Quality Parts,Customers Priority,Honest Operation,and Considerate Service”,our business mainly focus on the distribution of electronic components. Line cards we deal with include Microchip,ALPS,ROHM,Xilinx,Pulse,ON,Everlight and Freescale. Main products comprise IC,Modules,Potentiometer,IC Socket,Relay,Connector.Our parts cover such applications as commercial,industrial, and automotives areas.

We are looking forward to setting up business relationship with you and hope to provide you with the best service and solution. Let us make a better world for our industry!



Contact us

Tel: +86-755-8981 8866 Fax: +86-755-8427 6832

Email & Skype: info@chipsmall.com Web: www.chipsmall.com

Address: A1208, Overseas Decoration Building, #122 Zhenhua RD., Futian, Shenzhen, China





4-CH WD1 (960H)/D1 Compatible Video Decoders and Audio Codecs

TW2984

Features

Video Decoder

- WD1 (960H) and D1 compatible video decoding operation and it is programmable each channel
- NTSC (M, 4.43) and PAL (B, D, G, H, I, M, N, N combination), PAL (60) support with automatic format detection
- Built-in analog anti-alias filter
- Four 10-bit ADCs and analog clamping circuit for CVBS input
- Fully programmable static gain or automatic gain control for the Y channel
- Programmable white peak control for CVBS channel
- 4-H adaptive comb filter Y/C separation
- PAL delay line for color phase error correction
- Image enhancement with peaking and CTI
- Digital sub-carrier PLL for accurate color decoding
- Digital Horizontal PLL for synchronization processing and pixel sampling
- Advanced synchronization processing and sync detection for handling non-standard and weak signal
- Programmable hue, brightness, saturation, contrast, sharpness
- Automatic color control and color killer
- ITU-R 656 like YCbCr (4:2:2) output or time multiplexed output with 36/72/144MHz for WD1 or 27/54/108MHz for D1 format

Audio Codec

- Integrated five audio ADCs processing and one audio DAC
- Provides multi-channel audio mixed analog output
- Support I2S/DSP Master/Slave interface for record output and playback input
- PCM 8/16-bit and u-Law/A-Law 8-bit for audio word length
- Programmable audio sample rate that covers popular frequencies of 8/16/32/44.1/48kHz

Miscellaneous

- Two-wire MPU serial bus interface
- Integrated clock PLL for 144/108MHz clock output
- Power save and Power down mode
- Low power consumption
- Single 27MHz crystal for all standards and both WD1 and D1 format
- 3.3V tolerant I/O
- 1.0V/3.3V power supply
- 8mm x 8mm 68-pin QFN package

TW2984

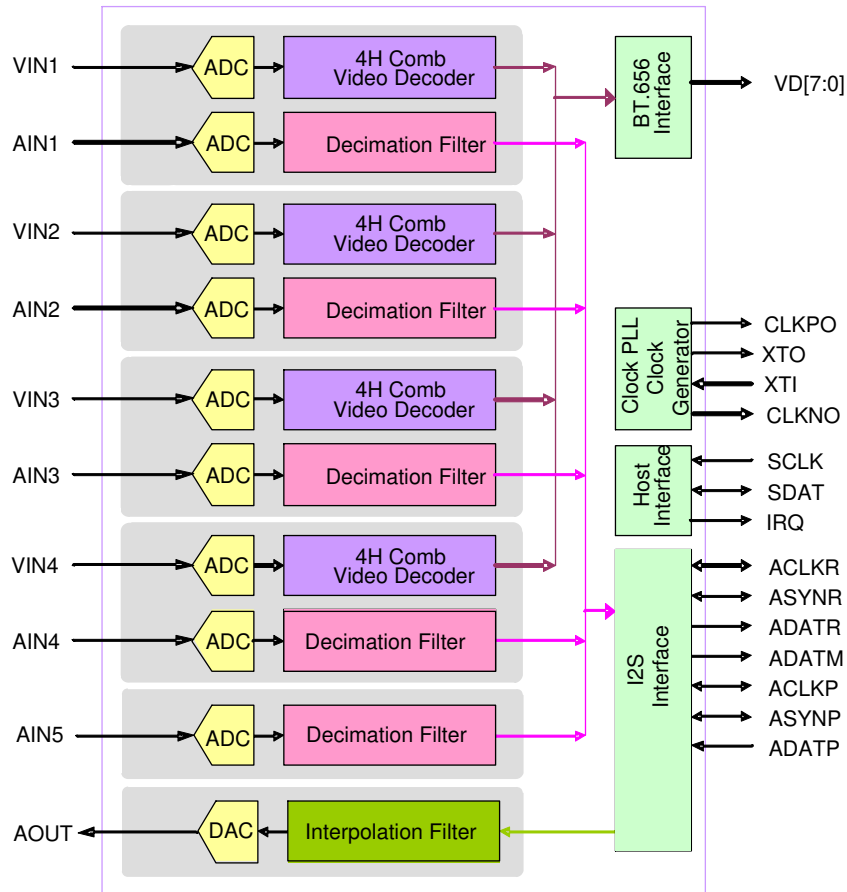

FIGURE 1. TW2984 BLOCK DIAGRAM

For additional products, see www.intersil.com/product_tree

Intersil products are manufactured, assembled and tested utilizing ISO9000 quality systems as noted in the quality certifications found at www.intersil.com/design/quality

Intersil products are sold by description only. Intersil Corporation reserves the right to make changes in circuit design, software and/or specifications at any time without notice. Accordingly, the reader is cautioned to verify that data sheets are current before placing orders. Information furnished by Intersil is believed to be accurate and reliable. However, no responsibility is assumed by Intersil or its subsidiaries for its use; nor for any infringements of patents or other rights of third parties which may result from its use. No license is granted by implication or otherwise under any patent or patent rights of Intersil or its subsidiaries.

For information regarding Intersil Corporation and its products, see www.intersil.com