



Chipsmall Limited consists of a professional team with an average of over 10 year of expertise in the distribution of electronic components. Based in Hongkong, we have already established firm and mutual-benefit business relationships with customers from,Europe,America and south Asia,supplying obsolete and hard-to-find components to meet their specific needs.

With the principle of “Quality Parts,Customers Priority,Honest Operation,and Considerate Service”,our business mainly focus on the distribution of electronic components. Line cards we deal with include Microchip,ALPS,ROHM,Xilinx,Pulse,ON,Everlight and Freescale. Main products comprise IC,Modules,Potentiometer,IC Socket,Relay,Connector.Our parts cover such applications as commercial,industrial, and automotives areas.

We are looking forward to setting up business relationship with you and hope to provide you with the best service and solution. Let us make a better world for our industry!



Contact us

Tel: +86-755-8981 8866 Fax: +86-755-8427 6832

Email & Skype: info@chipsmall.com Web: www.chipsmall.com

Address: A1208, Overseas Decoration Building, #122 Zhenhua RD., Futian, Shenzhen, China





To request the full datasheet, please visit www.intersil.com/products/TW9912

NTSC/PAL/SECAM Video Decoder with Component Input and Progressive Output Support

TW9912

Features

Video Decoder

- NTSC (M, 4.43) and PAL (B, D, G, H, I, M, N, N combination), PAL (60), SECAM support with automatic format detection
- Software selectable analog input control
- Built-in analog anti-alias filter
- Fully programmable static gain or automatic gain control for the Y channel
- Programmable white peak control for the Y channel
- 4-H adaptive comb filter Y/C separation
- PAL delay line for color phase error correction
- Image enhancement with peaking and CTI
- Digital sub-carrier PLL for accurate color decoding
- Digital Horizontal PLL for synchronization processing and pixel sampling
- Advanced synchronization processing and sync detection for handling non-standard and weak signal
- Programmable hue, brightness, saturation, contrast, and sharpness
- Automatic color control and color killer
- Chroma IF compensation
- VBI slicer supporting CC and WSS data services
- Programmable output control

Analog Video Input

- Triple 10-bit ADCs with independent clamping and gain control
- Supports 480i/480p/576i/576p analog component input with SOG

Digital Output

- ITU-R 656 compatible YCbCr(4:2:2) output format
- Progressive ITU-R 656 output format support for both interlaced and progressive inputs

Miscellaneous

- Two wire MPU serial bus interface
- Power save and Power down mode
- Low power consumption
- Single 27MHz crystal for all operations
- 3.3V tolerant I/O
- 1.8V/3.3 V power supply
- 48 pin QFN package

Functional Description

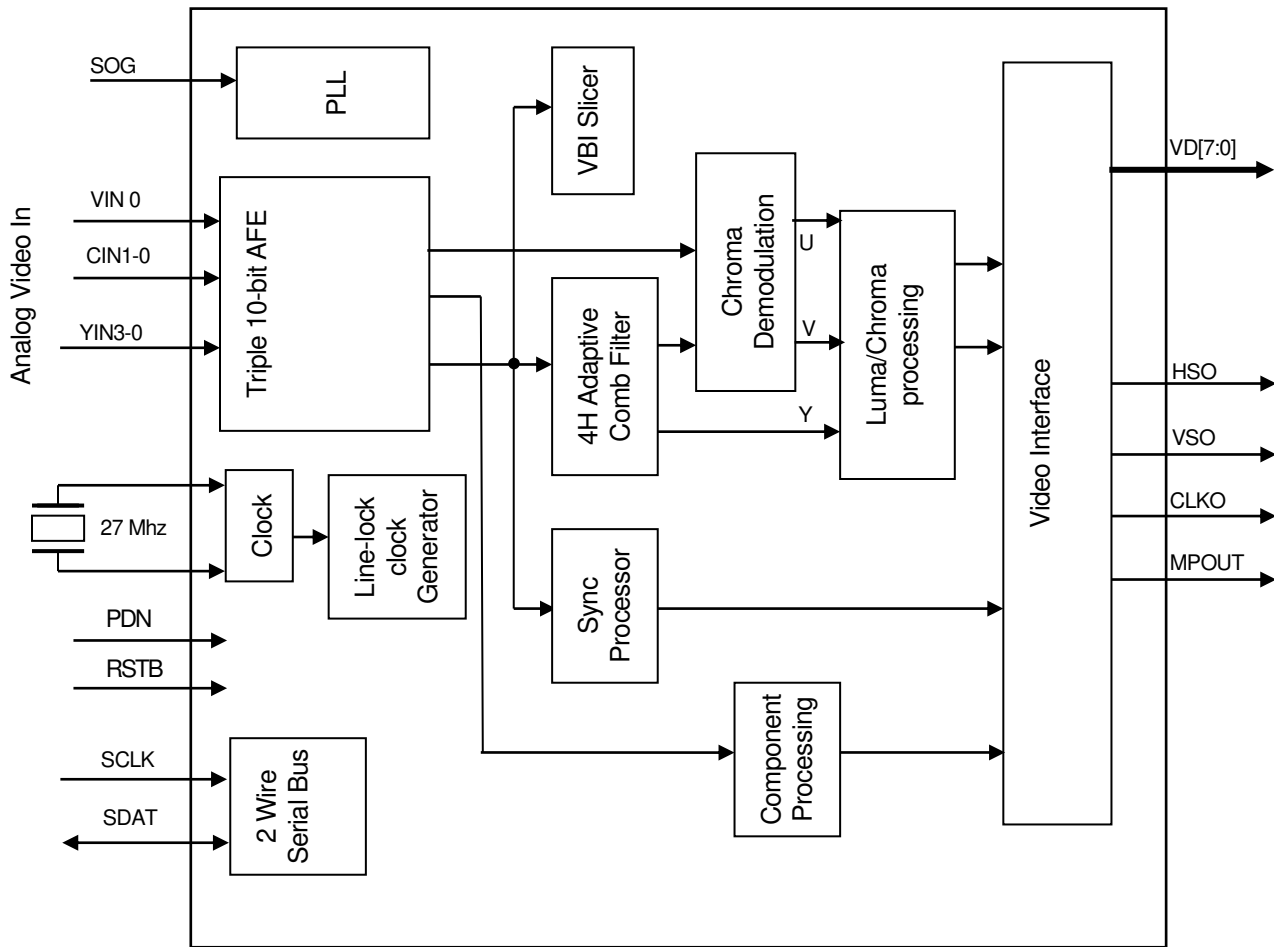

FIGURE 1. TW9912 BLOCK DIAGRAM

For additional products, see www.intersil.com/product_tree

Intersil products are manufactured, assembled and tested utilizing ISO9001 quality systems as noted in the quality certifications found at www.intersil.com/design/quality

Intersil products are sold by description only. Intersil Corporation reserves the right to make changes in circuit design, software and/or specifications at any time without notice. Accordingly, the reader is cautioned to verify that data sheets are current before placing orders. Information furnished by Intersil is believed to be accurate and reliable. However, no responsibility is assumed by Intersil or its subsidiaries for its use; nor for any infringements of patents or other rights of third parties which may result from its use. No license is granted by implication or otherwise under any patent or patent rights of Intersil or its subsidiaries.

For information regarding Intersil Corporation and its products, see www.intersil.com