



Chipsmall Limited consists of a professional team with an average of over 10 year of expertise in the distribution of electronic components. Based in Hongkong, we have already established firm and mutual-benefit business relationships with customers from,Europe,America and south Asia,supplying obsolete and hard-to-find components to meet their specific needs.

With the principle of “Quality Parts,Customers Priority,Honest Operation,and Considerate Service”,our business mainly focus on the distribution of electronic components. Line cards we deal with include Microchip,ALPS,ROHM,Xilinx,Pulse,ON,Everlight and Freescale. Main products comprise IC,Modules,Potentiometer,IC Socket,Relay,Connector.Our parts cover such applications as commercial,industrial, and automotives areas.

We are looking forward to setting up business relationship with you and hope to provide you with the best service and solution. Let us make a better world for our industry!



## Contact us

Tel: +86-755-8981 8866 Fax: +86-755-8427 6832

Email & Skype: info@chipsmall.com Web: www.chipsmall.com

Address: A1208, Overseas Decoration Building, #122 Zhenhua RD., Futian, Shenzhen, China



# Analog Video Decoder/Encoder

## TW9920

The [TW9920](#) is a multistandard video decoder and encoder chip that is designed for multimedia applications. This low power, integrated solution has a 4H comb filter based NTSC/PAL/SECAM video decoder that converts analog CVBS or S-Video signals into digital YCbCr output. The integrated analog video encoder converts digital YCbCr inputs into analog CVBS or S-Video output.

## Features

### Video Decoder

- NTSC (M, 4.43) and PAL (B, D, G, H, I, M, N, N combination), PAL (60), SECAM support with automatic format detection
- Software selectable analog inputs allow any of the following combinations, e.g., 4 CVBS or (3 CVBS and 1 Y/C)
- Two 9-bit ADCs and analog clamping circuit
- Fully programmable static gain or automatic gain control for the Y channel
- Programmable white peak control for the Y or CVBS channel
- 4-H adaptive comb filter Y/C separation
- PAL delay line for color phase error correction
- Image enhancement with 2D peaking and CTI
- Digital subcarrier PLL for accurate color decoding
- Digital horizontal PLL for synchronization processing and pixel sampling
- Advanced synchronization processing and sync detection for handling nonstandard and weak signal
- Programmable hue, brightness, saturation, contrast, sharpness, Gamma control, and noise suppression
- Automatic color control and color killer
- Detection of level of copy protection according to Macrovision standard
- Programmable output cropping
- ITU-R 601 or ITU-R 656 compatible YCbCr(4:2:2) output format
- VBI slicer supporting industrial standard data services
- VBI data pass through, raw ADC data for InterCast™

### Video Scaler

- High quality horizontal filtered scaling with arbitrary scale down ratio
- Phase accuracy better than 1/32 pixel
- Selectable antialias filter
- Vertical down scaling by line dropping

### Video Encoder

- Support NTSC/PAL and its substandard format output
- ITU-R 656 compatible video interface
- Luminance and chrominance filter
- Stable 27MHz crystal clock for subcarrier generation
- Five 10-bit digital-to-analog converters at 27MHz sample rate for generating CVBS or Y/C and YCbCr simultaneously

### Miscellaneous

- Two-wire MPU serial bus interface
- Power-down mode
- Field locked audio clock generation
- Typical power consumption 0.62W
- Single 27MHz crystal for all standards
- Supports 24.54MHz and 29.5MHz crystal for high resolution square pixel format decoding
- 3V tolerant I/O
- 2.5/3.3V power supply
- VFPGA package

# Block Diagram

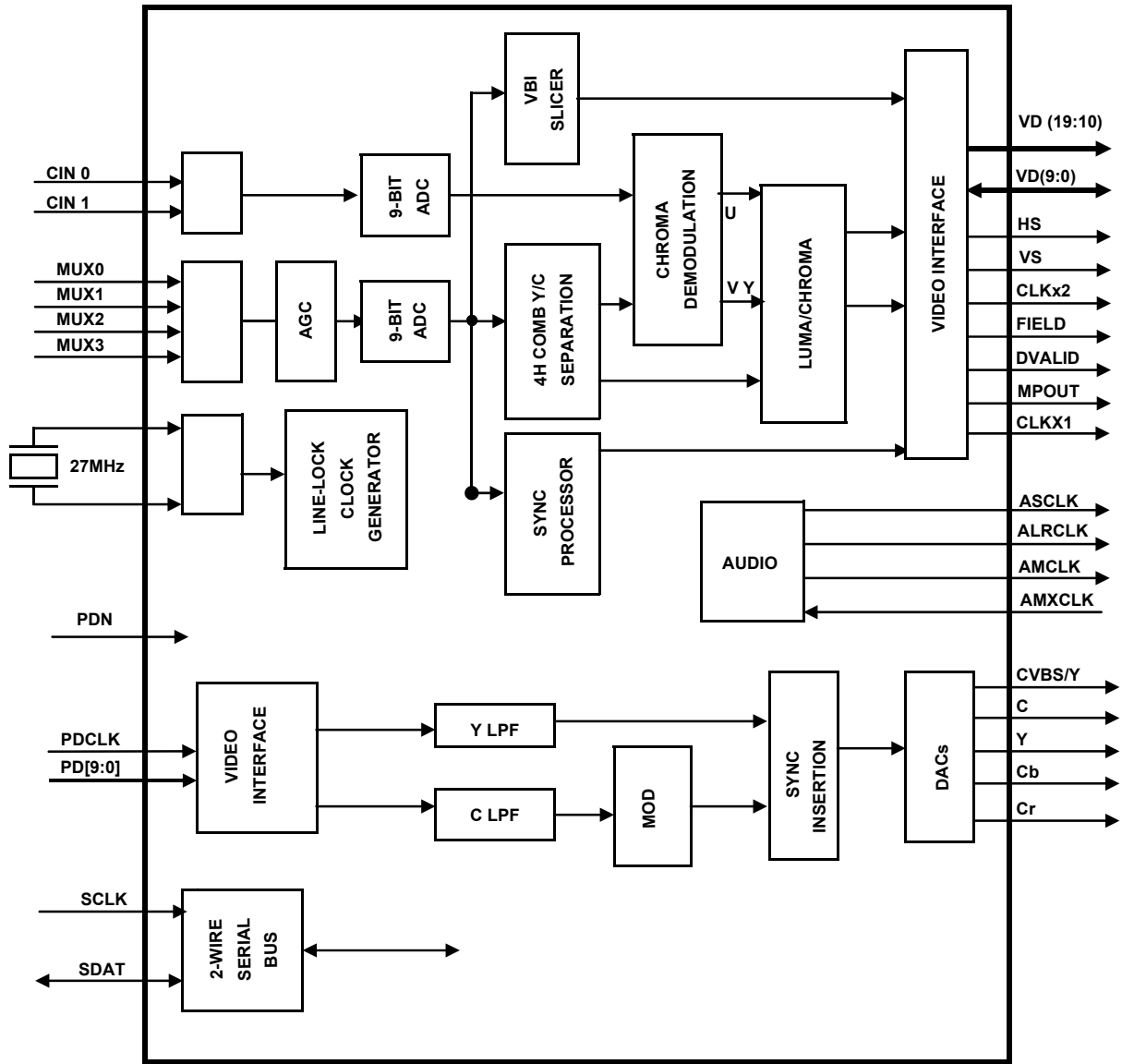

FIGURE 1. BLOCK DIAGRAM

For additional products, see [www.intersil.com/en/products.html](http://www.intersil.com/en/products.html)

Intersil products are manufactured, assembled and tested utilizing ISO9001 quality systems as noted in the quality certifications found at [www.intersil.com/en/support/qualandreliability.html](http://www.intersil.com/en/support/qualandreliability.html)

Intersil products are sold by description only. Intersil Corporation reserves the right to make changes in circuit design, software and/or specifications at any time without notice. Accordingly, the reader is cautioned to verify that data sheets are current before placing orders. Information furnished by Intersil is believed to be accurate and reliable. However, no responsibility is assumed by Intersil or its subsidiaries for its use; nor for any infringements of patents or other rights of third parties which may result from its use. No license is granted by implication or otherwise under any patent or patent rights of Intersil or its subsidiaries.

For information regarding Intersil Corporation and its products, see [www.intersil.com](http://www.intersil.com)