



Chipsmall Limited consists of a professional team with an average of over 10 year of expertise in the distribution of electronic components. Based in Hongkong, we have already established firm and mutual-benefit business relationships with customers from,Europe,America and south Asia,supplying obsolete and hard-to-find components to meet their specific needs.

With the principle of “Quality Parts,Customers Priority,Honest Operation,and Considerate Service”,our business mainly focus on the distribution of electronic components. Line cards we deal with include Microchip,ALPS,ROHM,Xilinx,Pulse,ON,Everlight and Freescale. Main products comprise IC,Modules,Potentiometer,IC Socket,Relay,Connector.Our parts cover such applications as commercial,industrial, and automotives areas.

We are looking forward to setting up business relationship with you and hope to provide you with the best service and solution. Let us make a better world for our industry!



Contact us

Tel: +86-755-8981 8866 Fax: +86-755-8427 6832

Email & Skype: info@chipsmall.com Web: www.chipsmall.com

Address: A1208, Overseas Decoration Building, #122 Zhenhua RD., Futian, Shenzhen, China



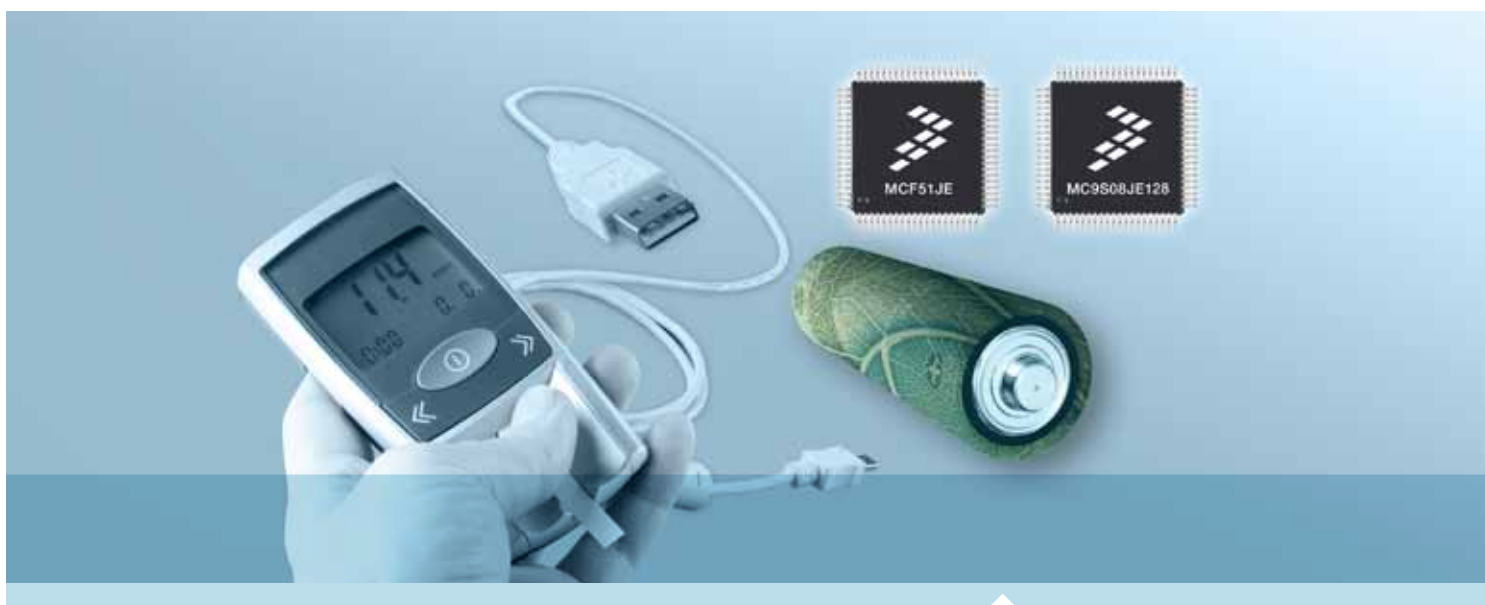

Flexis 32-bit Microcontrollers

MCF51JE256/128

Ultra-low-power MCU with USB connectivity



Target Applications

- HVAC building control systems
- PC peripherals
- Lighting control systems
- Industrial networking products
- Portable medical devices

Overview

The MCF51JE256/128 (JE256/128) provides ultra-low-power operation, USB connectivity and high measurement accuracy, all in a single 32-bit microcontroller, allowing designers to develop a more fully featured system at a lower cost. The JE256/128 integrates high-resolution ADC and DAC modules and a rich peripheral set including a USB 2.0 host/device/OTG controller, multiple serial interfaces and an external bus interface.

The JE256/128 is part of the Freescale Flexis microcontroller series, which includes both 8-bit S08 and 32-bit V1 ColdFire microcontrollers that have a common set of peripherals and development tools to deliver the ultimate in migration flexibility. The JE256/128 family is also easy to use. Freescale provides a comprehensive suite of development tools and software to help developers design quickly and easily.

MCF51JE256 Block Diagram

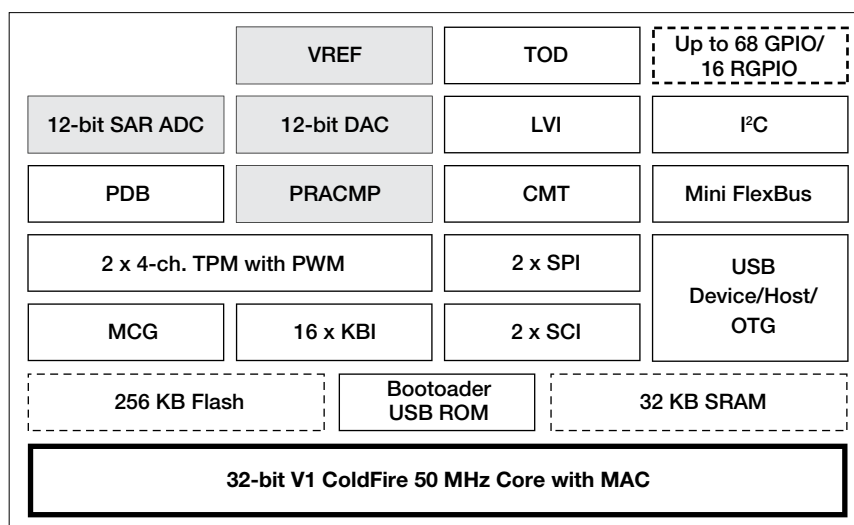

Modular Tower Development System

TWR-MCF51JE-KIT (\$119 USD*)

TWR-MCF51JE (\$69 USD*)

The Freescale Tower development system provides the user with a modular, reconfigurable demonstration and development platform.

The TWR-MCF51JE-KIT soldered with 100LQFP MCF51JE256 consists of:

- TWR-MCF51JE stand-alone development board
- TWR-SER serial boards that support USB and RS232
- TWR-ELEV elevator board that connects the MCU and serial boards
- USB cable

The TWR-MCF51JE can also be ordered independently. A getting-started DVD included with the board includes necessary software, documents and resources to jumpstart new product development.

CodeWarrior Development Studio for Microcontrollers v6.3/10.x

Special Edition (Complimentary)**

CodeWarrior Development Studio for Microcontrollers is an integrated tool suite that supports software development for Freescale’s microcontrollers. Designers can further accelerate application development with the help of the award-winning Processor Expert tool in the CodeWarrior tool suite.

Freescale MQX RTOS and USB Software Stack (complimentary)**

With the powerful integration of JE256/128 family, Freescale provides full production source code of Freescale MQX software:

- RTOS: Full priority-based, pre-emptive scheduler
- USB host/device
- MS-DOS file system (MFS)

Product Selector Guide

Part Number	Temp. Ranges	Package
MCF51JE256CML	-40°C to +85°C	104 MAPBGA
MCF51JE256CLL	-40°C to +85°C	100 LQFP
MCF51JE256CMB	-40°C to +85°C	81 MAPBGA
MCF51JE256CLK	-40°C to +85°C	80 LQFP
MCF51JE128CMB	-40°C to +85°C	81 MAPBGA
MCF51JE128CLK	-40°C to +85°C	80 LQFP
MCF51JE256VML	-40°C to +105°C	104 MAPBGA
MCF51JE256VLL	-40°C to +105°C	100 LQFP
MCF51JE256VMB	-40°C to +105°C	81 MAPBGA
MCF51JE256VLK	-40°C to +105°C	80 LQFP
MCF51JE128VMB	-40°C to +105°C	81 MAPBGA
MCF51JE128VLK	-40°C to +105°C	80 LQFP

Features	Benefits
CPU and System Configuration	
<ul style="list-style-type: none"> • 32-bit V1 ColdFire CPU Offering 46 MIPS at 50 MHz • 1.8V to 3.6V single supply 	<ul style="list-style-type: none"> • Offers high performance across the entire voltage range
On-Chip Memory	
<ul style="list-style-type: none"> • Up to 256 KB flash • Up to 32 KB SRAM • Mini FlexBus (external bus interface) 	<ul style="list-style-type: none"> • Allows the user to take full advantage of in-application re-programmability benefits in any environment • Security circuitry helps to prevent unauthorized RAM access • Glueless connection to external memory devices
Power Management	
<ul style="list-style-type: none"> • Low-power operation mode 	<ul style="list-style-type: none"> • Low-power Stop 2 current: 550 nA with 32K of SRAM enabled and active POR • 6 uS wake-up time from Stop 3 • 32 kHz oscillator for low-power time keeping • Rapid response to interrupts from the low-power sleep mode
Analog Related Peripherals	
<ul style="list-style-type: none"> • 12-bit ADC • 12-bit DAC • Programmable delay block • VREF (voltage reference) 	<ul style="list-style-type: none"> • High-resolution and high-accuracy ADC provides accurate signal acquisition • Digital-to-analog converter with clock gating optimized for low-power usage • PDB precisely triggers ADC and DAC blocks to complete sensor biasing and measurement (i.e. glucometry strips) • VREF accuracy is 33 ppm/°C from 0 °C to 50°C
Communication Peripherals	
<ul style="list-style-type: none"> • USB 2.0 controller • Dual asynchronous SCIs • Inter IC-BUS (I²C) • Dual synchronous SPI (1 x 64-bit FIFO SPI) 	<ul style="list-style-type: none"> • USB device/host/On-The-Go controller • On-chip transceiver and 3.3 volt regulator reduces system cost • Serial communication interface provides a simple, efficient method of data exchange between devices. Option to connect analog comparator to SCI for opto-isolation applications • I²C port enables increased system memory by using an additional I²C EEPROM • Two SPIs allow two separate dedicated devices, for example, one SPI dedicated to a ZigBee® transceiver and the other to MCUs or peripherals. SPI FIFO allows better performance to drive a graphic LCD.
Software and Tools	
<ul style="list-style-type: none"> • Background debug mode (BDM) for in-circuit debugging • Complimentary Freescale MQX software solutions, RTOS, USB, file system and strong third-party alliance network • Medical applications USB stack • Tower development system 	<ul style="list-style-type: none"> • Real-time trace and debug support • Value added tools and software, stacks and RTOS • Standardize with the “Continua Ready” personal health care device (PHDC) USB solution • The Freescale Tower System is a modular, reconfigurable demonstration and development platform

As other USB MCUs from Freescale, the JE256/128 devices are supported by USB stack with MSD, HID, CDC and PHDC classes. This USB stack can also be used for medical applications.

* Prices indicated are MSRP

** Subject to license agreement

Learn more: For current information about Freescale products and documentation, please visit freescale.com/MCF51JE.