



Chipsmall Limited consists of a professional team with an average of over 10 year of expertise in the distribution of electronic components. Based in Hongkong, we have already established firm and mutual-benefit business relationships with customers from,Europe,America and south Asia,supplying obsolete and hard-to-find components to meet their specific needs.

With the principle of "Quality Parts,Customers Priority,Honest Operation,and Considerate Service",our business mainly focus on the distribution of electronic components. Line cards we deal with include Microchip,ALPS,ROHM,Xilinx,Pulse,ON,Everlight and Freescale. Main products comprise IC,Modules,Potentiometer,IC Socket,Relay,Connector.Our parts cover such applications as commercial,industrial, and automotives areas.

We are looking forward to setting up business relationship with you and hope to provide you with the best service and solution. Let us make a better world for our industry!



## Contact us

Tel: +86-755-8981 8866 Fax: +86-755-8427 6832

Email & Skype: info@chipsmall.com Web: www.chipsmall.com

Address: A1208, Overseas Decoration Building, #122 Zhenhua RD., Futian, Shenzhen, China



Product Drawing and Specification

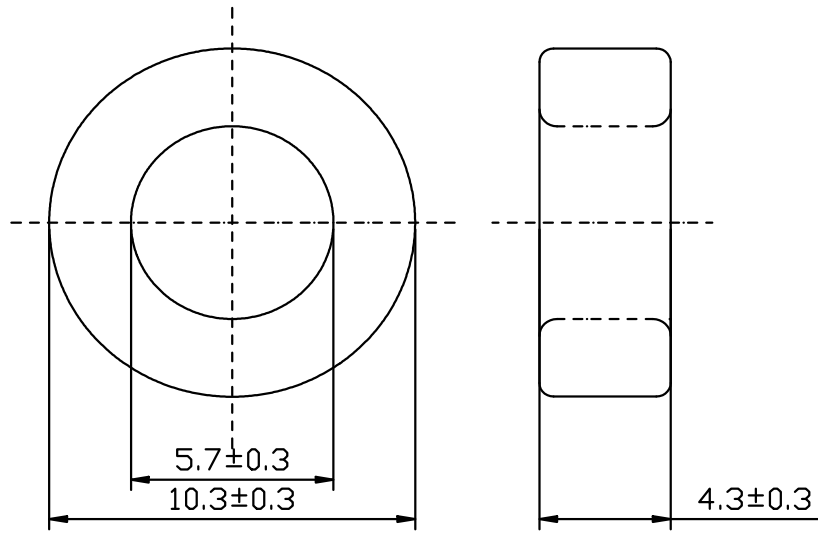

Dimensions According To: IEC 205

$\Sigma 1/A : 3.07\text{mm}^{-1}$	$\Sigma 1/A^2 : 0.39\text{mm}^{-3}$	$A_e : 7.8\text{mm}^2$	$V_e : 188\text{mm}^3$	$L_e : 24.1\text{mm}$
Weight ~0.95g/ pcs				

Electrical Specifications

Property	Specification	Unit	Test Conditions			
			Frequency	Induction	Temperature	Equipment <sup>(1)</sup>
			(kHz)	(mT)	(°C)	
$A_L$	<b>52<sub>+25%</sub></b>	nH/ N <sup>2</sup>	10	≤0.1	25 <sub>+3</sub>	HP-4284A
$\text{tg } \delta / u_i$	<b>≤130*10<sup>-6</sup></b>	---	10 <sup>4</sup>			HP-4285A



(1): Or similar

OTHER SPECIFICATIONS

VISUAL REQUIREMENTS according to: GUV-4-0-0/ 1

High voltage insulation ≥ 1 kV

Maximum working temperature 160°C/ Temperatura maxima de trabalho 160°C

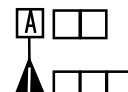
ROUGHNESS	UNIT	SCALE	PROJ EUROP	UN-D 28	TOLERANCES: UNLESS OTHERWISE STATED DIMENSION: ±3% ACC: TO DIN 406 TEIL 4	UN-D 603
	mm	2:1				
4C65: MA01			<b>CORE- FAMILY</b> <b>TX10/6/4-4C65</b>  Toroid coated with epoxy			1   2005/ 3/ 11
6TG : 531530						
2005/ 3/ 11						<b>4341 030 3480_</b>
- -						
Name: Hongmei He	Check:	Approve:	<b>110 - 02</b>	010		A 4
TR	Date. 2005/ 3/ 11	Property of Ferroxcube Dongguan Ltd.-China				