



Chipsmall Limited consists of a professional team with an average of over 10 year of expertise in the distribution of electronic components. Based in Hongkong, we have already established firm and mutual-benefit business relationships with customers from,Europe,America and south Asia,supplying obsolete and hard-to-find components to meet their specific needs.

With the principle of "Quality Parts,Customers Priority,Honest Operation,and Considerate Service",our business mainly focus on the distribution of electronic components. Line cards we deal with include Microchip,ALPS,ROHM,Xilinx,Pulse,ON,Everlight and Freescale. Main products comprise IC,Modules,Potentiometer,IC Socket,Relay,Connector.Our parts cover such applications as commercial,industrial, and automotives areas.

We are looking forward to setting up business relationship with you and hope to provide you with the best service and solution. Let us make a better world for our industry!



## Contact us

Tel: +86-755-8981 8866 Fax: +86-755-8427 6832

Email & Skype: info@chipsmall.com Web: www.chipsmall.com

Address: A1208, Overseas Decoration Building, #122 Zhenhua RD., Futian, Shenzhen, China



**Nazwa / Name**  
**Numer kodu / Code number**

**TX22/14/13-3C90**  
**4327 030 11091**

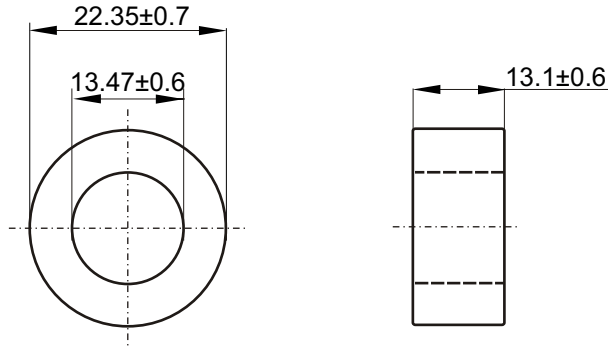

**Magnetical dimensions according to: / Właściwości magnetyczne zgodne z: IEC 205**

$\Sigma l/A$ (mm <sup>-1</sup> )	$\Sigma l/A^2$ (mm <sup>-3</sup> )	$A_e$ : 50.9 mm <sup>2</sup>	$l_e$ : 54.18 mm	$V_e$ : 2756 mm <sup>3</sup>
1.06	0.02			
				Weight/Waga: ≈ 13.9 g

**Specified value / Wartości specyfikowane**

Symbol Symbol	Nominal Nominał	Tolerance Tolerancja	Unit Jednostka	Frequency Częstotliwość f [kHz]	Induction Indukcyjność [mT]	Equipment (Sprzęt pomiarowy) (1)	Temperature Temperatura t [°C]
Al	2795	±20%	nH	10	0.5	Agilent 4284A	25±3

**(1) Or similar / Lub podobny**

**VISUAL REQUIREMENTS according to: I-15-002**

**KONTROLA WIZUALNA według: I-15-002**

**High voltage insulation >1kV / Napięcie przebicia izolacji >1kV**

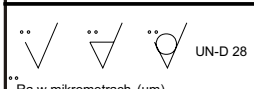
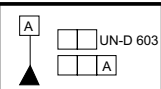
		Tolerances unless otherwise stated Tolerancja (jeśli nie ustalono inaczej) Dimensions Wymiary ±3%   Angle Kąt				Name Nazwisko Grzegorz Winczewski		Signature Podpis Marek Kaczorowski		Date Data 07-03-13	
General Roughness Chropowatość		Unit Jednostka mm.		MATERIAL 3C90 acc. to KPN-K1959 MATERIAL 3C90 zgodnie z: KPN-K1959		Check Sprawdził		Approval Zatwierdził		Other Inne	
Scale None Skala Brak		PROJ.EURO PROJ.EURO		TX22/14/13-3C90		TYPE NUMBER / TYP		LAB REF No.		---	
Status/Status		Toroid coated: Epoxy Cream RAL 1014 Toroid pokryty: Epoxy kremowy RAL 1014		4327 030 11090		D C B A		07-03-13		110-02	
Issued by: Wydano przez: J.Krawczyk / K.S.		SUPERSEDES ZASTĘPUJE		SHEETS STRONY 1 SHEET STRONA 110-02		DATE DATA 07-03-13		Property of WŁAŚCICIEL		Ferroxcube Polska Sp. z o.o. SKIERNIEWICE, POLAND	
K.S.		Property of WŁAŚCICIEL		DATE DATA 07-03-13		A-4		UNCONTROLLED COPY generated electronically, conform with original up to the date of its creation KOPIA NIEKONTROLOWANA wygenerowana elektronicznie, zgodna z oryginałem w dniu jego zatwierdzenia		---	